

---

**CDC® 752 KEYBOARD  
DISPLAY TERMINAL**

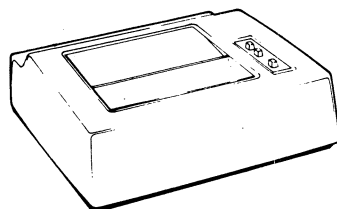
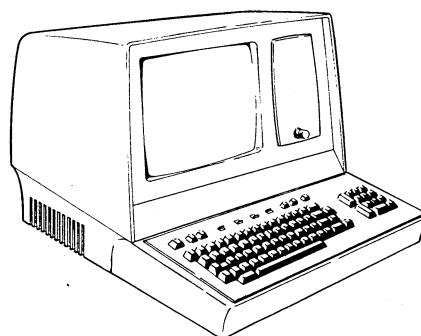
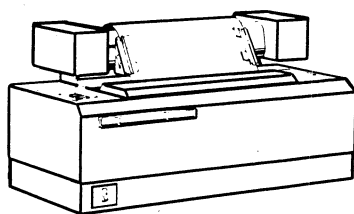

---

**OPERATORS GUIDE/REFERENCE MANUAL  
INSTALLATION INSTRUCTIONS**

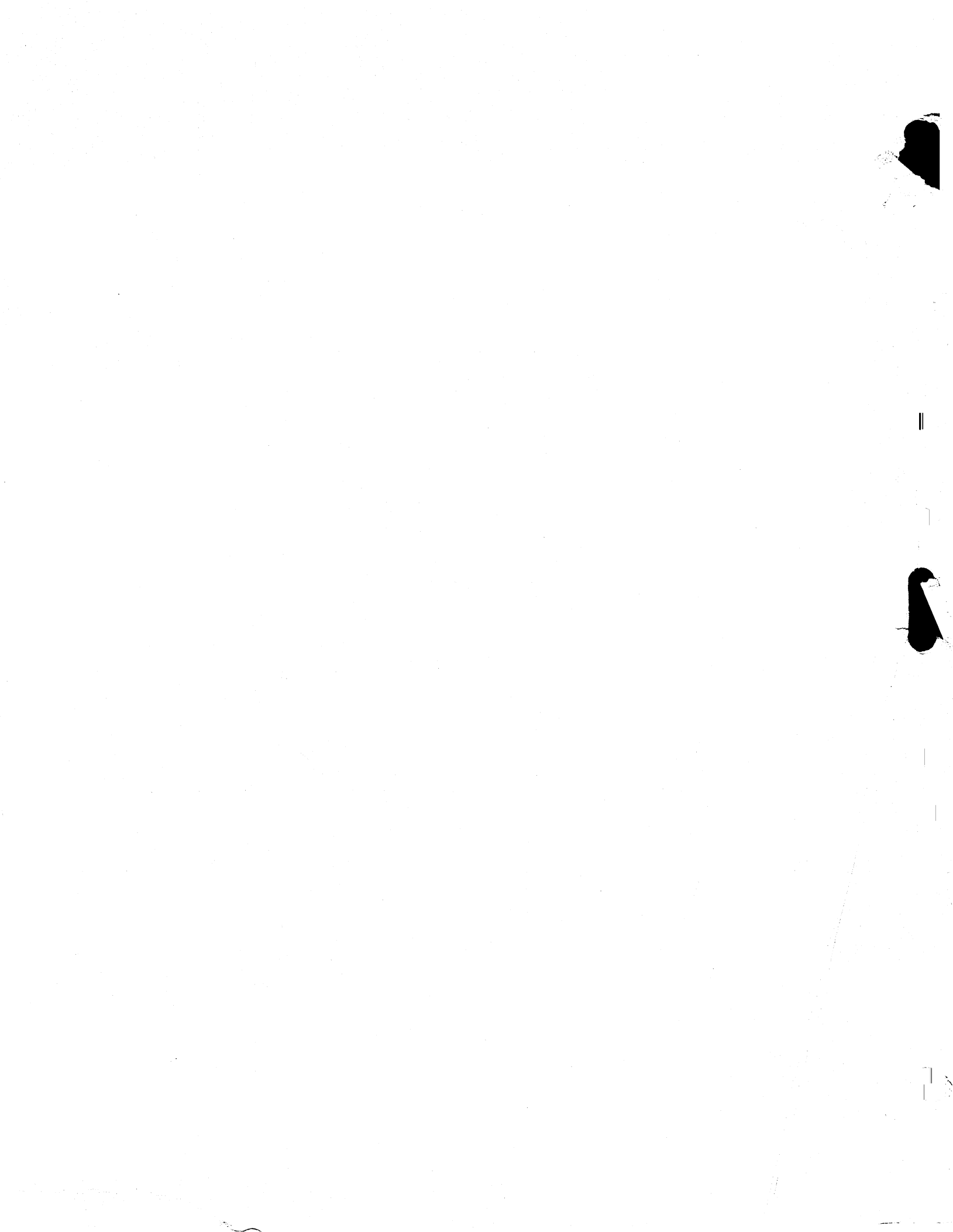



---

**CDC<sup>®</sup> 752 KEYBOARD  
DISPLAY TERMINAL**

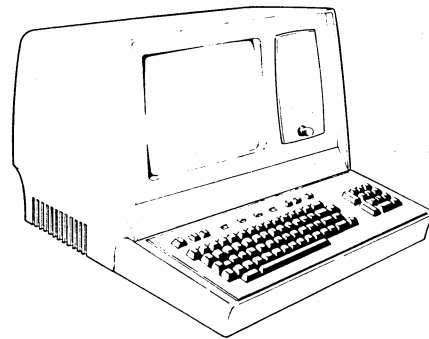
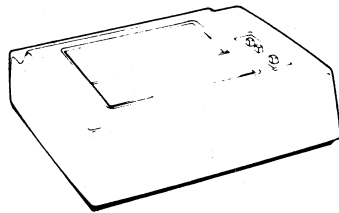
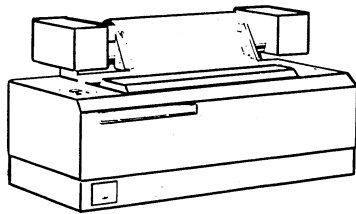

---

**OPERATORS GUIDE/REFERENCE MANUAL  
INSTALLATION INSTRUCTIONS**





## LIST OF EFFECTIVE PAGES

New features, as well as changes, deletions, and additions to information in this manual are indicated by bars in the margins or by a dot near the page number if the entire page is affected. A bar by the page number indicates pagination rather than content has changed.

PAGE	REV	PAGE	REV	PAGE	REV
Cover	-	A-6	F		
Title Page	-	A-7	B		
Impact Matrix Printer	-	A-8	F		
Updates (Deleted)	-	A-9	B		
v thru viii	F	A-10	F		
ix and x	D	A-11 thru A-20	B		
xi and xii	A	B-1/B-2	B		
xiii thru xvi	F	Ci thru Cv	C		
1-1	F	C1-1 thru C1-5	C		
1-2 thru 1-8	A	C2-1 thru C2-18	C		
1-9	F	C2-19	F		
1-10 thru 1-19	A	C2-20 thru C2-22	C		
2-1	F	C2-23	F		
2-2 thru 2-17	A	C3-1	C		
2-18 and 2-19	E	C4-1 thru C4-9	C		
2-20	A	C5-1 thru C5-3	C		
2-21	E	D-1 thru D-10	C		
2-22 thru 2-30	A	E-1 thru E-4	D		
2-31	F	Comment Sheet	G		
2-32 thru 2-38	A	Mailer	-		
3-1 thru 3-8	A	Back Cover	-		
4-1	F				
4-2 thru 4-5	A				
4-6 thru 4-8	F				
4-9 and 4-10	A				
5-1	E				
A-1 thru A-5	B				

## IMPACT MATRIX PRINTER

NOTE: Customers using the CDC<sup>®</sup>725-10 Impact Matrix Printer should read the following paragraphs.

The Control Data Matrix Printer is compatible with the following terminals: CDC<sup>®</sup>714-123, 714-30, 714-40, 714-125, 722-10, 751, 752, and 756. A precaution and the required settings for the serial interface switches are given here. For information about installation and operation, refer to the CDC Matrix Printer Operator Installation and Reference Manual, publication number 15051290. For maintenance information, refer to the CDC Matrix Printer Hardware Maintenance Manual, publication number 15051295. The manuals are available from:

Control Data Corporation  
Literature and Distribution Services  
308 North Dale Street  
St. Paul, Minnesota 55103

### CAUTION

Before replacing the ac power line fuse, disconnect the power cord and/or switch power off.

Three banks of serial interface switches (shown below) are at the rear of the printer. Switch banks A and C are set to allow the printer to signal the data source to start or stop data transmission. Switch bank B is used to set the Baud rate and the number of STOP and of DATA bits.

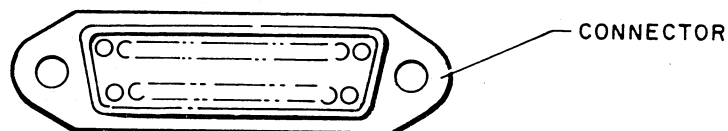
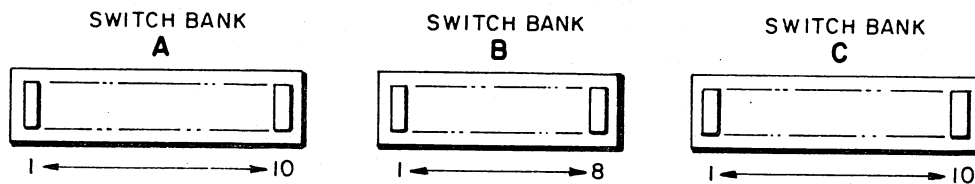

The serial interface switches must be positioned as follows:

SWITCH NUMBER	SWITCH POSITION	FUNCTION
A-1	OFF	SIGNAL GROUND not connected to FRAME GROUND
A-2	OFF	No RECEIVED DATA on pin 2
A-3	ON	RECEIVED DATA on pin 3
A-4	ON	X-ON/X-OFF disabled
A-5	OFF	No constant +5V on pin 4, no simulated REQUEST TO SEND
A-6	OFF	No constant +5V on pin 20, no simulated DATA TERMINAL READY
A-7	OFF	X-ON/X-OFF not transmitted on pin 2
A-8	OFF	X-ON/X-OFF not transmitted on pin 3
A-9	OFF	No Parity
A-10	OFF	EVEN Parity (ON-odd parity)
B-1	OFF	No 9600 Baud
B-2	OFF	No 4800 Baud
B-3	OFF	No 2400 Baud
B-4	OFF	No 1200 Baud
B-5	ON	300 Baud
B-6	OFF	No 110 Baud
B-7	ON	1 STOP bit (OFF-2 STOP Bits)
B-8	OFF	8 DATA bits (ON-7 DATA Bits)
C-1	OFF	No BUSY on pin 11
C-2	OFF	No BUSY on pin 19
C-3	OFF	No BUSY on pin 4
C-4	ON	BUSY on pin 20
C-5	OFF	No CHARACTER BUSY -
C-6	OFF	No CHARACTER BUSY +
C-7	ON	BUFFER BUSY -
C-8	OFF	No BUFFER BUSY +
C-9	ON	Constant +5V on pin 19, simulated SECONDARY REQUEST TO SEND
C-10	ON	Constant +5V on pin 11

- Notes:
1. Switches B-1 through B-6 set the Baud rate to correspond to the data source. Only one of these switches can be ON.
  2. Position POWER switch to OFF (red "0" shows) before changing switch positions.
  3. When 714 display terminal is set for an impact printer, select 9600 Baud.
  4. The 751 terminal has an additional Baud rate switch on printer option card XA-151-A which must be set to agree with terminal and printer Baud rate switches. At greater than 1200 Baud turn C-9 and C-10 off to enable a full screen print.

## PREFACE

---

This manual contains operating and reference information for the CDC<sup>®</sup> 752 Keyboard Display Terminal. Basically this terminal is a remote communications device that operates in a conversational mode with a central processor at speeds of 110 to 9600 baud over a communication facility. The terminal is available in variant types to meet both national and international standards and to provide for connection to different communications facilities. Three different character printers are also available for use as a peripheral on the terminal.

The main body of this manual contains information for reference by both systems personnel and terminal operators, and appendixes A and B contain terminal installation information for reference by technical personnel. Appendixes C and D contain operating and installation instructions for the 70-LPM impact printer and operating instructions for the 82-key typewriter keyboard, respectively. Appendix E contains reference, operation, and installation information for the terminals that are compatible with IBM\* Series/1 systems. Maintenance information for the terminal equipments is found in other CDC manuals.

To order additional copies of this manual, or copies of other manuals associated with this terminal, please contact:

Control Data Corporation  
Literature and Distribution Services  
304 North Dale Street  
St. Paul, Minnesota 55103

---

\* IBM is a registered trademark of International Business Machines Corporation.



# CONTENTS

<u>Section</u>		<u>Page</u>
1	— GENERAL DESCRIPTION	
	Functions .....	1-2
	Features .....	1-2
	Display Unit Features .....	1-3
	Power Supply .....	1-3
	CRT Monitor Assembly .....	1-3
	Control Logic PC Board .....	1-4
	Keyboard Features .....	1-4
	Operator Control Features .....	1-6
	System/Terminal Interface Features .....	1-7
	Nonimpact Printer Features .....	1-9
	Print Mechanism .....	1-11
	Interface and Control Logic Cards .....	1-11
	Power Supply .....	1-11
	Impact Printer Features .....	1-11
	Print Mechanism .....	1-13
	Interface and Control Logic Cards .....	1-13
	Power Supply .....	1-13
	Features Summary List .....	1-14
	Equipment Specifications .....	1-15
	Environmental Specifications .....	1-16
	Keyboard Display Electrical Specifications .....	1-16
	Nonimpact Printer Electrical Specifications .....	1-16
	Impact Printer Electrical Specifications .....	1-17
	Keyboard Display Physical Specifications .....	1-17
	Nonimpact Printer Physical Specifications .....	1-17
	Impact Printer Physical Specifications .....	1-17
2	— OPERATION	
	Keyboard Display Controls and Indicators .....	2-1
	Internal Controls .....	2-1
	BAUD RATE Switches .....	2-3
	AUTO LINE FEED Switch .....	2-3
	MARK PARITY Switch .....	2-3
	50 Hz Switch .....	2-3
	SWITCHED RTS Switch .....	2-3
	CONSTANT DTR Switch .....	2-4
	INTERNAL TEST Switch .....	2-4

Section

Page

X/Y POSITION Switch	2-5
CURRENT LOOP Switch	2-5
Interface Jumpers	2-5
External Controls	2-6
INTENSITY Control	2-6
CO Indicator	2-7
ODD PAR/NO/EVEN PAR Switch	2-7
FULL DUP/HALF DUP Switch	2-7
ON LINE/LOCAL Switch	2-8
HIGH RATE/300/LOW RATE Switch	2-8
96/64 Switch	2-8
PAGE Switch	2-9
CBI Switch	2-9
TEST/NORMAL Switch	2-9
Keyboard Data Entry and Control Keys	2-10
CLEAR Key	2-12
BREAK Key	2-12
ESC Key	2-12
SHIFT LOCK Key	2-12
SHIFT Keys	2-12
CONTROL Key	2-13
CONTROL Plus Keys	2-13
Fixed Code Keys	2-13
Cursor Movement Keys	2-14
Special CONTROL Key Functions	2-15
Line Clear	2-15
Initiate Low Intensity	2-16
End Highlight	2-16
Initiate Blink	2-16
ETX Key	2-16
RUB OUT Key	2-16
CARRIAGE RETURN Key	2-17
Cursor Positioning (↑, ←, and →) Keys	2-17
Cursor Up (↑)	2-17
Backspace (←)	2-17
Skip (→)	2-17
RESET Key	2-18
LINE FEED Key	2-18
REPEAT Key	2-18
ENTER- Key	2-18
ENTER+ Key	2-18

Section

Page

Nonimpact Printer Controls and Indicators . . . . .	2-19
On Switch Indicator . . . . .	2-19
LF Switch . . . . .	2-19
CR Switch . . . . .	2-20
Single-Double Space Switch . . . . .	2-20
Impact Printer Controls and Indicators . . . . .	2-20
ON/OFF Switch Indicator . . . . .	2-21
START/STOP Switch Indicator . . . . .	2-21
FORM FEED Switch . . . . .	2-21
Test Print Switch . . . . .	2-21
Forms Positioning Knobs . . . . .	2-21
Forms Density Control . . . . .	2-22
Horizontal Forms Positioning . . . . .	2-22
Preparation for Operation . . . . .	2-22
Display Terminal . . . . .	2-23
Check Items . . . . .	2-23
Specific Functions . . . . .	2-24
Nonimpact Printer . . . . .	2-24
Check Items . . . . .	2-24
Specific Functions . . . . .	2-25
Impact Printer . . . . .	2-26
Check Items . . . . .	2-27
Specific Functions . . . . .	2-28
Forms Installation and Alignment . . . . .	2-28
Ribbon Installation . . . . .	2-29
Format Tape Installation . . . . .	2-31
Operator Supplies . . . . .	2-31
Nonimpact Printer . . . . .	2-31
Impact Printer . . . . .	2-32
Forms Recommendations . . . . .	2-32
Ribbon Recommendations . . . . .	2-32
Format Tape . . . . .	2-33
Terminal Operation . . . . .	2-33
General Operating Information . . . . .	2-33
ODD PAR/NO/EVEN PAR Switch . . . . .	2-33
ON LINE/LOCAL Switch . . . . .	2-33
FULL DUP/HALF DUP Switch . . . . .	2-34
HIGH RATE/300/LOW RATE Switch . . . . .	2-34
96/64 Switch . . . . .	2-34
PAGE Switch . . . . .	2-35

<u>Section</u>		<u>Page</u>
	Online Operation .....	2-35
	Establishing Communications .....	2-35
	Logging In to the System .....	2-36
	Sending Messages .....	2-36
	Receiving Messages .....	2-36
	Logging Out of the System .....	2-37
	Offline or Local Operation .....	2-37
3	— SUBSYSTEM COMMUNICATIONS	
	Transmit/Receive Baud Rates .....	3-1
	Half- and Full-Duplex Modes of Operation .....	3-2
	Transmit/Receive Word Sizes and Formats .....	3-2
	Transmit/Receive Code Set .....	3-4
	Error Detection .....	3-7
	Current Loop Communication Interface .....	3-7
4	— CODES AND CHARACTER SETS	4-1
5	— EQUIPMENT CARE	5-1

## APPENDIXES

A	— INSTALLATION INSTRUCTIONS	A-1
B	— IMPACT PRINTER PRINT RATES	B-1
C	— 70-LPM IMPACT PRINTER	C-1
D	— 82-KEY TYPEWRITER KEYBOARD	D-1
E	— KEYBOARD DISPLAY TERMINALS FOR SERIES/1 SYSTEMS	E-1

## FIGURES

<u>Section</u>	<u>Figure</u>	<u>Page</u>
1	— GENERAL DESCRIPTION	
	1-1 Terminal Configurations .....	1-2
	1-2 Display Unit Components .....	1-3
	1-3 Keyboard Layout .....	1-5
	1-4 Terminal Rear Panel .....	1-6
	1-5 Nonimpact Character Printer .....	1-10

<u>Section</u>	<u>Figure</u>	<u>Page</u>
	1-6 Nonimpact Printer Components . . . . .	1-10
	1-7 Impact Character Printer . . . . .	1-12
	1-8 Impact Character Printer Components . . . . .	1-12
	1-9 Keyboard Display Terminal Dimensions . . . . .	1-18
	1-10 Nonimpact Printer Dimensions . . . . .	1-19
	1-11 Impact Printer Dimensions . . . . .	1-19
2	— OPERATION	
	2-1 Cabinet Hood Removal . . . . .	2-2
	2-2 Internal Switches and Jumpers . . . . .	2-2
	2-3 External Controls, Keyboard and Front Panel . .	2-6
	2-4 External Controls, Terminal Rear Panel . . . . .	2-9
	2-5 Keyboard Key Layout . . . . .	2-11
	2-6 Nonimpact Printer Controls and Indicators . . . .	2-18
	2-7 Impact Printer Controls and Indicators . . . . .	2-20
	2-8 Terminal with Printer Option . . . . .	2-22
	2-9 Removing the Detachable Keyboard . . . . .	2-23
	2-10 Loading Paper in Nonimpact Printer . . . . .	2-26
	2-11 Spool Loading . . . . .	2-29
	2-12 Ribbon Loading . . . . .	2-30
	2-13 Front Tape Installation . . . . .	2-31
3	— SUBSYSTEM COMMUNICATIONS	
	3-1 Word Transmit Sequence . . . . .	3-3
	3-2 Terminal Code Set . . . . .	3-5
	3-3 Data Set Connector Pin Assignments for Unipolar, Full-Duplex, Current Loop Communication Channel . . . . .	3-8
	3-4 Data Set Connector Pin Assignments for Unipolar, Half-Duplex, Current Loop Communication Channel . . . . .	3-8
4	— CODES AND CHARACTER SETS	
	4-1 Alphanumeric Dot-Matrix Formations and Octal Codes . . . . .	4-2
	4-2 Control Code Dot-Matrix Formations and Octal Codes . . . . .	4-5
	4-3 Nonimpact Printer Character Repertoire . . . . .	4-7
	4-4 Impact Printer Character Repertoire . . . . .	4-9

# TABLES

---

<u>Section</u>	<u>Table</u>	<u>Page</u>
1	— GENERAL DESCRIPTION	
	1-1 Available Terminal Configurations . . . . .	1-1
	1-2 Peripheral Connector Pin Assignments . . . . .	1-7
	1-3 Voltage Level Channel Interface Connector Pin Assignments . . . . .	1-8
2	— OPERATION	
	2-1 Impact Printer Forms Requirements . . . . .	2-32
3	— SUBSYSTEM COMMUNICATIONS	
	3-1 Terminal Control Codes . . . . .	3-6
4	— CODES AND CHARACTER SETS	
	4-1 Display Keyboard Alphanumeric Character Set . . . .	4-1
	4-2 Nonimpact Printer Alphanumeric Character Set . . . . .	4-6

# GENERAL DESCRIPTION

This section describes the general functions, features, and equipment specifications of the 752 Keyboard Display Terminal and of the three printers that may be associated with the terminal.\* It includes descriptions of both the basic terminal and its available variations.

The basic terminal is a 50- or 60-Hz terminal with either an 80-key keyboard, or an 82-key typewriter keyboard and a modem interface. The user can select 60-Hz versions of the terminal with a current loop interface for connection to a current loop communication facility or can select 50-Hz versions with a current loop interface and/or FTZ approved shielding.\*\* The features incorporated in each type of 752 Keyboard Display Terminal are indicated with Xs in table 1-1.

TABLE 1-1. AVAILABLE TERMINAL CONFIGURATIONS

EQUIPMENT CC555	60 Hz	50 Hz	CURRENT LOOP	FTZ SHIELDING	CA150-A*	CA150-B*	CA150-C*	CA150-D*
-A	X	—	—	—	—	—	—	—
-B	—	X	—	—	—	—	—	—
-C	X	—	X	—	—	—	—	—
-D	—	X	X	X	—	—	—	—
-E	—	X	—	—	—	—	—	—
-F	—	X	X	—	—	—	—	—
-G	X	—	—	—	X	X	—	—
-H	—	X	—	X	—	—	X	X
-J	X	—	X	—	X	X	—	—
-K	—	X	X	X	—	—	X	X

\* Keyboards are documented as separate equipments. CA150-A and CA150-C are 80-key keyboards; CA150-B and CA150-D are 82-key typewriter keyboards.

Additionally, the terminal is available with either a nonimpact thermal printer or an impact printer. The keyboard display terminal and the two different printers are shown in figure 1-1.

\* The 70-LPM impact printer information is available in appendix C.

\*\* FTZ (Fernmelde Technisches Zentralamt) is a German licensing agency that sets limits on the radio frequency emissions generated by electrical and electronic devices. Many European countries have adopted FTZ requirements for the shielding of electronic equipment in order to control the level of stray radio frequencies in the atmosphere.

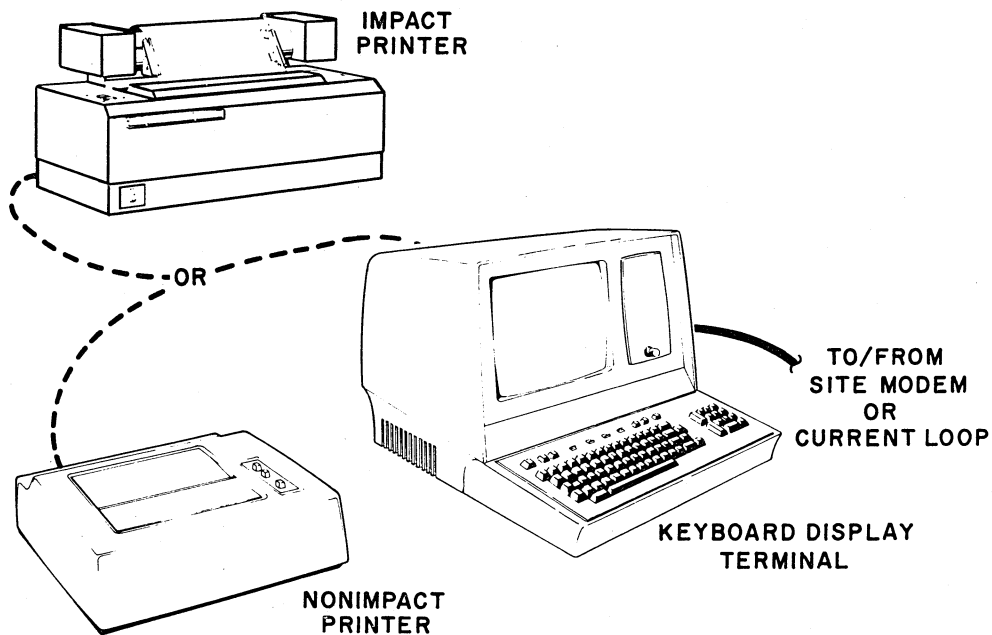

02201

NOTE: BROKEN LINES SHOW INTER-CONNECTING CABLE PATHS.

Figure 1-1. Terminal Configurations

## FUNCTIONS

The keyboard display terminal functions as a stand-alone, remote input/output device for a computer system. It performs input and terminal-control functions via a detachable keyboard assembly, and it monitors both input and output functions on a 12-inch crt display screen. Included within the terminal are all of the necessary electronics, including an asynchronous, bit-serial, word-serial, communication facility interface, to permit it to operate in conversational mode in the same manner as a teletypewriter unit. The display terminal, however, incorporates many features not commonly found in teletypewriter terminals; and the addition of one of the available printer peripherals provides the terminal with hardcopy printout capabilities.

## FEATURES

The following text highlights features of the terminal. These are described in the following sequence: 1) display unit features, 2) keyboard features, 3) operator control features, 4) system/terminal interface features, 5) nonimpact printer features, 6) impact printer features, and 7) features summary list. Other portions of this manual describe many of these features in greater detail; this portion of text provides brief descriptions and a features summary to facilitate familiarization and comparison.

## DISPLAY UNIT FEATURES

The display unit of the terminal is a self-contained module that includes a power supply, a crt monitor assembly, and a control-logic board. The keyboard, communication line, and printer unit interfaces are part of the logic PC board. The location of major components within the display unit is shown in figure 1-2.

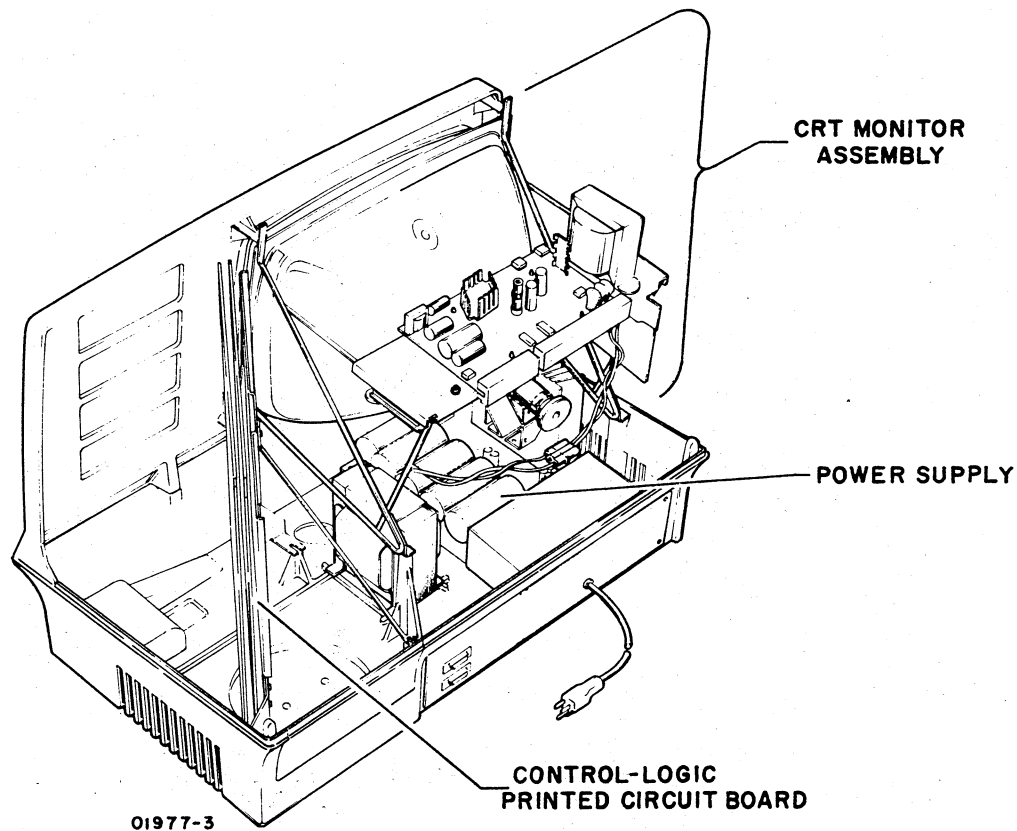

Figure 1-2. Display Unit Components

### Power Supply

The power supply furnishes all necessary voltages for the display module from either 115 V ac or 220/240 V ac (nominal), 50- or 60-Hz power input sources.

### CRT Monitor Assembly

The crt monitor assembly uses a 12-inch (diagonal measurement) crt, having a P4, white-phosphor coating and a nonglare faceplate. Nominal raster area on the display screen is an area approximately 7.8 in by 5 in (20 cm by 12 cm). This area can display 24 lines of up to 80 characters per line, with each character displayed in a 7- by 9-dot matrix. Character display is accomplished by selectively blanking

and unblanking the dots within this matrix. A display-character refresh memory holds all the characters for display and refreshes the display screen at a rate equal to the frequency of the ac power input (50 or 60 Hz).

### **Control Logic PC Board**

The display recognizes and generates 128 character codes; the 95 alphanumeric character codes recommended by the American National Standards Institute (ANSI) in standard X3.4-1968, and the 33 control codes recommended by ANSI in standard X3.2-1973. During actual operation, the unit displays all 95 alphanumeric characters and responds to 13 of the 33 control codes as they are received. This leaves 20 control codes for use in specific functions or operations (refer to section 3 for transmit/receive code set). All 128 codes can be transmitted during normal online operation of the terminal.

Character entries onto the display screen occur upon code reception or are made via the keyboard module. To assure entry at the desired screen location, a blinking cursor underscores the location of the next character entry. During consecutive character entries, the cursor progresses across a display line through all 80 character positions. At character position 73, a beeper signal sounds to warn the operator that the end of a line is approaching. This line-by-line manner of cursor advance continues until the last character position of the last line is reached. As the last character is keyed in, the cursor resets to its home position (upper left corner of display area) or causes the display to scroll; that is, the cursor returns to the beginning of the last line while all lines already entered scroll up one line (the first line is lost as it scrolls off the screen).

Construction of the display unit is modular as indicated in figure 1-2. All circuits are solid-state, and with the exception of some of the power supply and high voltage circuits, all use integrated circuit technology. Both the display unit and the keyboard enclosures are made of heavy-gauge, molded, expanded-plastic, foam material covered with a durable vinyl paint. The overall design of the display unit lends itself to reliability, and the modular construction facilitates maintenance procedures.

### **KEYBOARD FEATURES**

The keyboard of the terminal serves as both a terminal control and a data input unit for the terminal operator. The terminal control function of the keyboard is discussed briefly in the following portion of this section and more thoroughly in section 2 of this manual. This portion of the text deals principally with the keyboard as a data input unit. The keyboard uses a main key cluster of 67 keys, similar in appearance to a standard teletypewriter keyboard, and a 13-key numeric-entry cluster, to facilitate making numeric entries, located just to the right of the main key cluster.

All keycaps are of a wear-resistant plastic with molded-in characters to assure legibility even after long usage, and all have a matte-finish surface to minimize glare. The layout of the keys on the keyboard module is shown in figure 1-3.

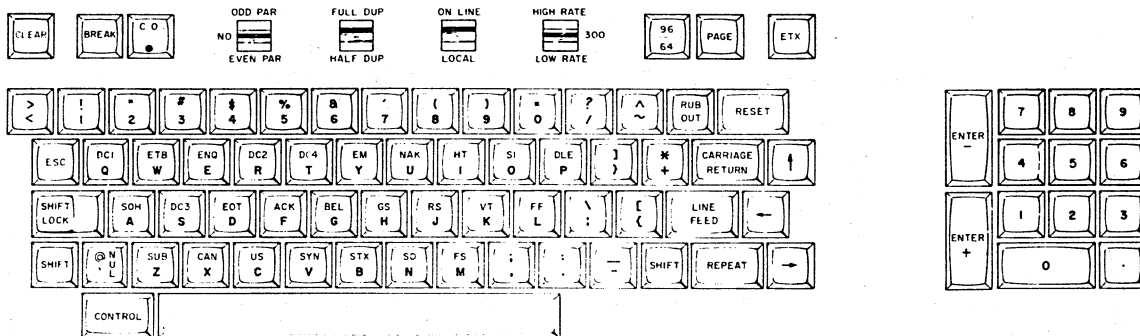

01499-6

Figure 1-3. Keyboard Layout

The keyboard itself is a modular unit that attaches to the display unit module via an interconnecting cable approximately 32 in (80 cm) long. All power required by the keyboard comes from the display module power supply via this cable, and all data and control codes generated by the keyboard are passed on to the logic circuits of the display module via this same cable.

The keyboard features tri-level operation; that is, it operates in lowercase mode, uppercase mode (SHIFT key actuated), and in control mode (CONTROL and character keys actuated; or SHIFT, CONTROL, and character keys actuated). In this manner, the keyboard can be used to generate a full 128-character, ASCII\* compatible code set. The complete character and code sets used in the terminal are included in section 4 of this manual.

Data entry from the keyboard is accomplished by simply typing in the desired control codes and/or alphanumeric characters on the keyboard. During online operation, transmission occurs as each key is pressed regardless of the state of any other keys on the keyboard. As a message is typed and sent in the half-duplex mode of terminal operation, it displays on the screen of the display module to permit visual verification of proper message format and content. Additional message verification is provided in full-duplex mode operation, which permits only received data to be displayed (such as, transmitted data echoed back from the receiving station). Regardless of the transmission mode selected, where the data is displayed on the screen depends on the operating mode selected (page or scroll) and on the position of the cursor as data entry begins.

\* American Standard Code for Information Interchange.

## OPERATOR CONTROL FEATURES

The keyboard display terminal has operator controls located on the keyboard and on the front and rear panels of the display unit. The controls most commonly used by the operator during terminal operation are located on the keyboard module. The layout of these controls across the top of the keyboard is indicated in figure 1-3. Following is a list of these keyboard controls; their functions are described in section 2, Operation, of this manual.

- CO indicator
- ODD PAR/NO/EVEN PAR switch
- FULL DUP/HALF DUP switch
- ON LINE/LOCAL switch
- HIGH RATE/300/LOW RATE switch
- 96/64 switch
- PAGE switch

Just to the right of the display screen, the front panel carries a single-control knob. This is the INTENSITY control knob and is used to adjust the intensity of the crt display to suit ambient lighting conditions in the area of terminal installation.

The terminal rear panel, shown in figure 1-4, carries the data set and peripheral connectors, a test switch, the ac power cord, and circuit breaker CBI. The CBI serves as the terminal on/off switch, and therefore, is used to apply or remove ac power to the terminal. The test switch is for use when testing or checking terminal operation.

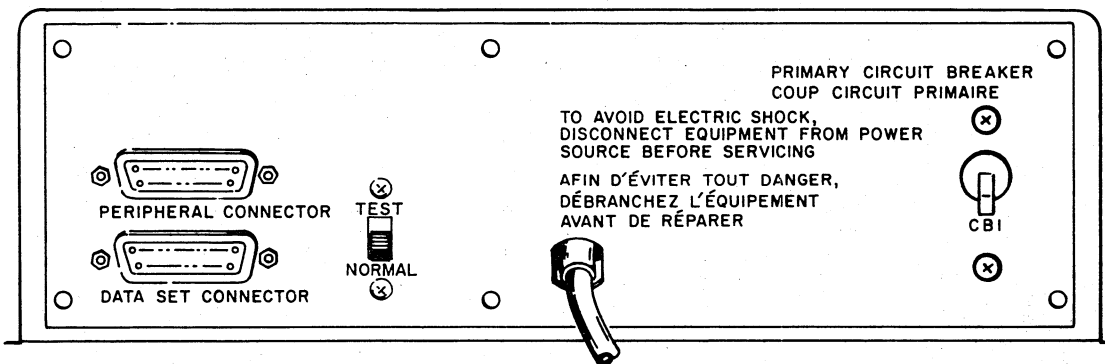

Figure 1-4. Terminal Rear Panel

## SYSTEM/TERMINAL INTERFACE FEATURES

The terminal has two interface connectors on the rear panel. The PERIPHERAL CONNECTOR is used to connect either the impact printer or the nonimpact printer to the terminal. The DATA SET CONNECTOR is used to connect the terminal to the communications facility. The connector pin assignments for the peripheral connector are shown in table 1-2. Pin assignments for the data set connector vary with the type of communication facility being interfaced, either current loop or voltage level. The connector pin assignments for voltage level channel connections are shown in table 1-3. Pin assignments for current loop channels are much simpler and are described a little later in this portion of the text.

The printer interface is compatible with RS-232-C and CCITT V.24 recommendations for full- or half-duplex, asynchronous communications facilities. The purpose of the printer interface is to enable hardcopy records of communications to be produced via a peripheral printer. In a manner similar to the display, only received information is routed to the printer during full-duplex, online operation of the terminal; while both received and transmitted information is routed to the printer during half-duplex, online operation. Both the printer and the communication channel baud rate selectors must be set for the same transfer rates.

TABLE 1-2. PERIPHERAL CONNECTOR PIN ASSIGNMENTS

PIN NUMBER	CCITT	EIA	SIGNAL NAME	ORIGIN
1	101	AA	Protective Ground	Printer/Terminal
2	—	—	Not Used	—
3	104	BB	Received Data	Terminal
4	—	—	Not Used	—
5	—	—	Not Used	—
6	107	CC	Data Set Ready (DSR)	Terminal
7	102	AB	Signal Ground	Printer/Terminal
8	109	CF	Received Line Signal Detector (CO)	Terminal
9	—	—	Not Used	—
↓	↓	↓	↓	↓
25	—	—	Not Used	—

TABLE 1-3. VOLTAGE LEVEL CHANNEL INTERFACE  
CONNECTOR PIN ASSIGNMENTS

PIN NUMBER	CCITT	EIA	SIGNAL NAME	ORIGIN
1	101	AA	Protective Ground	Modem/Terminal
2	103	BA	Transmitted Data	Terminal
3	104	BB	Received Data	Modem
4	105	CA	Request to Send (RTS)	Terminal
5	106	CB	Clear to Send (CTS)	Modem
6	107	CC	Data Set Ready (DSR)	Modem
7	102	AB	Signal Ground	Modem/Terminal
8	109	CF	Received Line Signal Detector (CO)	Modem
9	—	—	Not Used	—
10	—	—	Not Used	—
11	—	—	Secondary Request to Send (SRTS)*	—
12	122	SCF	Secondary Received Line Signal Detector (SCO)	Not Used
13	121	SCB	Secondary Clear to Send (SCTS)	Not Used
14	118	SBA	Secondary Transmitted Data	Not Used
15	114	DB	Transmission Signal Element Timing	Not Used
16	119	SBB	Secondary Received Data	Not Used
17	115	DD	Receiver Signal Element Timing	Not Used
18	—	—	Not Used	—
19	120	SCA	Secondary Request to Send (SRTS)	Terminal
20	108.2	CD	Data Terminal Ready (DTR)	Terminal
21	110	CG	Signal Quality Detector	Not Used
22	125	CE	Ring Indicator	Not Used
23	111	CH	Data Signal Rate Selector	Terminal
24	113	DA	Transmit Signal Element Timing	Not Used
25	—	—	Not Used	—

\* Data set connector has pin 11 jumpered to pin 19.

In local mode operation of the terminal, keyed-in data is directed to both the display screen and to the peripheral printer, regardless of the setting of the half-duplex/full-duplex switch. Selection of local mode always disconnects the transmit interface of the terminal, while the receive interface may be either maintained or disabled via switch conditioning within the terminal, see CONSTANT DTR Switch heading in section 2.

The rear-panel data set connector is used to interface voltage level terminals to a voltage level communication facility, and current loop terminals to a current-loop communication facility. As indicated in table 1-3, terminals interfacing voltage level communication facilities use RS-232-C/CCITT V.24 compatible signals to and from the data set connector. Current loop terminals use receive and transmit circuits designed to interface a 20-milliampere current loop communication facility. Current loop terminals use data set connector pins depending on the type of current loop facility being connected. Unipolar, half-duplex facilities use pin 2 for transmit data and pin 3 for receive data; and unipolar, full-duplex facilities use pin 2 for transmit data, pin 3 for receive data, and pin 7 as a common receive/transmit channel ground.\* Although all current loop terminals use the same transmit and receive circuits, internal conditioning of terminals used on a half-duplex current loop facility differs slightly from that of terminals used on a full-duplex current loop facility (see section 3, Subsystem Communications, of this manual).

With the exception of their different communication facility interfaces, voltage level and current loop terminals operate in an identical manner.

## **NONIMPACT PRINTER FEATURES**

The nonimpact character printer, see figure 1-5, operates as an output peripheral in conjunction with the keyboard display terminal. It prints a maximum of 30 characters per second (300 baud) in serial order, and checks for character parity per setting of its PARITY switch. A full print line is 80 characters maximum.

The printer cabinet contains the following major functional components: a print mechanism, interface and control logic cards, and a power supply. The position of these components within the printer cabinet is shown in figure 1-6.

---

\* Where only 4-wire, full-duplex, current loop communications facilities are available, the separate receive channel and transmit channel grounds are tied together for connection to pin 7 of the data set connector.

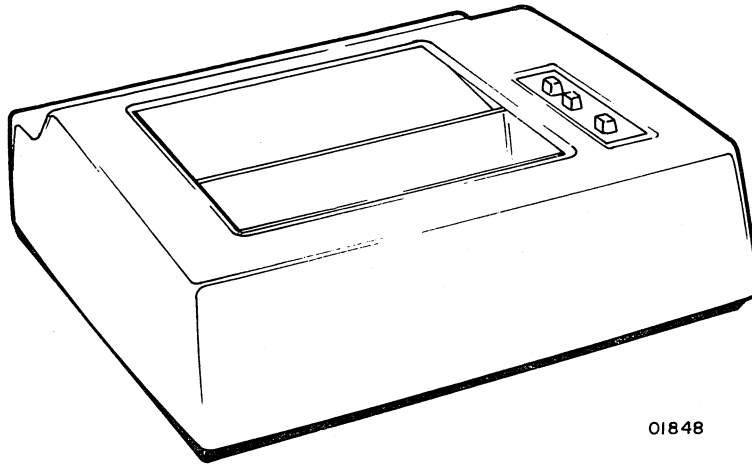

01848

Figure 1-5. Nonimpact Character Printer

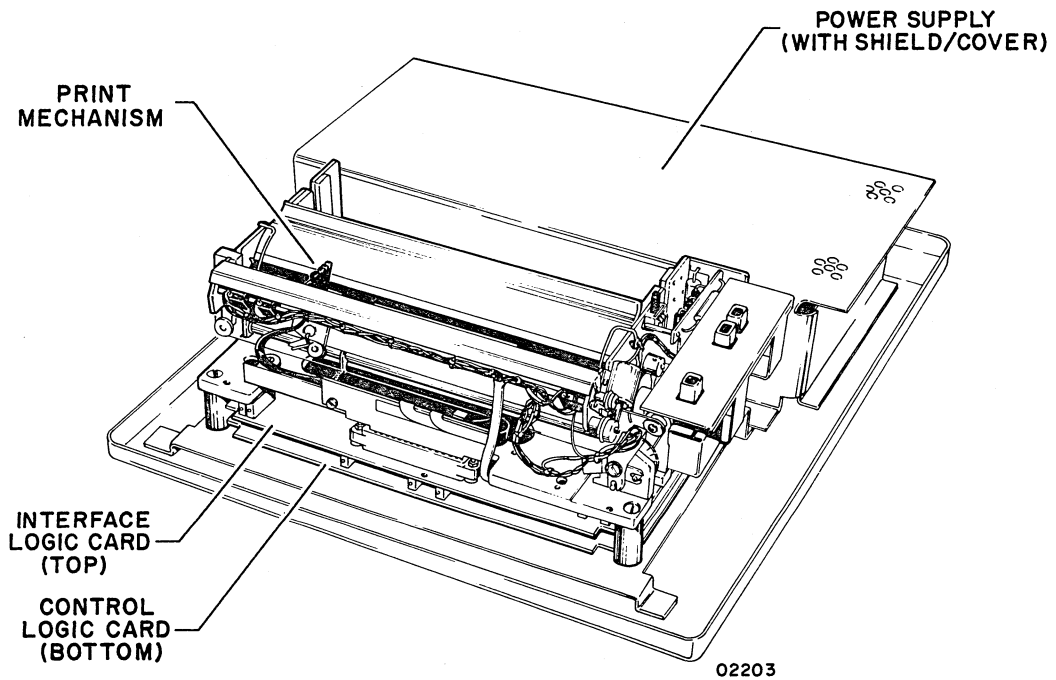

02203

Figure 1-6. Nonimpact Printer Components

## **Print Mechanism**

The print mechanism consists of the electromechanical elements necessary to print characters and to advance the roll-type heat-sensitive paper on which characters are printed. Printing is done by a single printhead that consists of a set of heater elements arranged in a 5- by 7-dot matrix. A character prints by bringing the printhead into contact with the heat-sensitive paper and quickly heating the matrix elements necessary to reproduce the desired character. Multicopy records cannot be made on this type of printer. The printer is capable of reproducing the 95 (including space) uppercase and lowercase characters and symbols listed in section 4 of this manual. It responds to the following ASCII control codes: backspace, line feed, and carriage return.

## **Interface and Control Logic Cards**

The interface and control logic cards contain circuits for interfacing the printer to the keyboard display terminal and for controlling printer operation. The interface card accepts serial outputs from the terminal, assembles and decodes these outputs, and directs them to the appropriate circuits (data outputs to the printhead and control outputs to the control logic). The control card provides timing and control signals for all printer operations.

## **Power Supply**

The nonimpact printer power supply is a single, removable assembly that provides four regulated dc voltages: +5 V dc for all logic circuits, +16 V dc for the print mechanism, +24 V dc for the print mechanism, and -24 V dc for the printer/terminal interface circuits. All outputs have overcurrent and overvoltage protection.

## **IMPACT PRINTER FEATURES**

The impact character printer, shown in figure 1-7, operates as a peripheral for the keyboard display terminal in lieu of the nonimpact printer. It prints characters in serial order at speeds of up to 173 characters per second in a 60-Hz version or 180 characters per second in a 50-Hz version. It includes internal switches for selecting 150, 300, 600, or 1200 baud data reception rates and for selecting either odd or even parity checking of received codes. Although the impact printer has a print-line capacity of 132 characters, the use of line-feed and carriage-return control codes can format a print line to match the display-line format of 80 characters.

The printer cabinet contains the following major functional components: a print mechanism, interface and control logic cards, and a power supply. Figure 1-8 shows the location of these components within the printer cabinet, and the following text briefly describes each component.

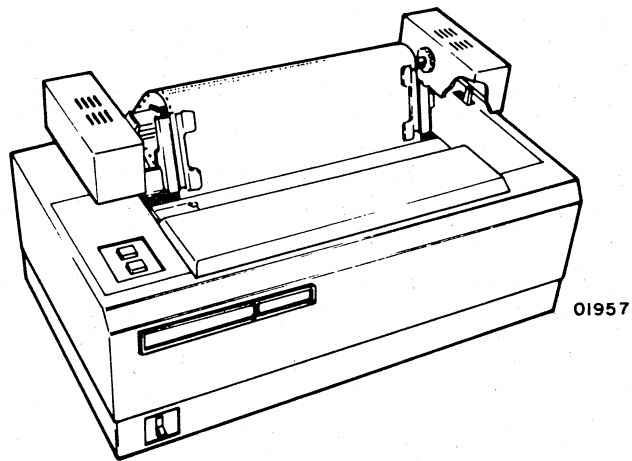
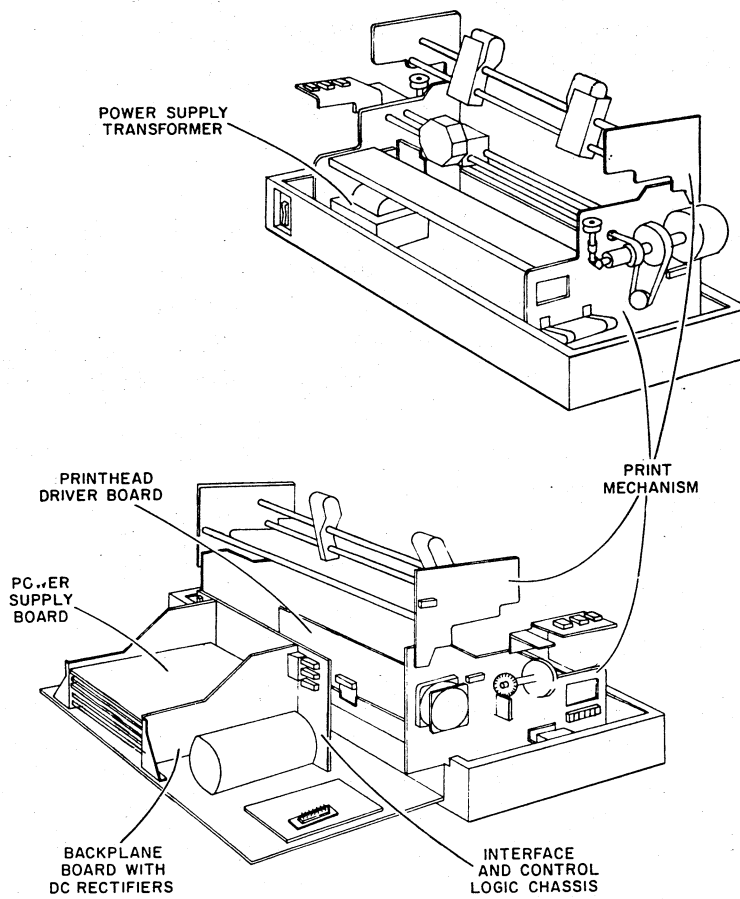

Figure 1-7. Impact Character Printer



02202

Figure 1-8. Impact Character Printer Components

## **Print Mechanism**

The print mechanism consists of all the electromechanical components necessary to print characters and to move the paper forms on which characters are printed. The mechanism uses standard, fan-folded, single or multicopy (up to five parts) paper forms. The printhead of the mechanism consists of a set of impact pin elements arranged in a vertical 1- by 7-dot matrix. This printhead prints one vertical column at a time within a 7- by 7-dot character matrix. Printing is accomplished by bringing the required pins into contact with an inked ribbon, which in turn transfers the dot pattern to a paper form. Electric solenoids actuate the particular pins for printing each portion of a desired character, which is determined by decoding the signals received via the terminal/printer interface. The printer is capable of reproducing the 95 (including space) uppercase and lowercase characters and symbols listed in section 4 of this manual, and it responds to the following ASCII control codes: carriage return, line feed, vertical tabulation, and form feed. Other device control codes cause the printhead to space a character position.

## **Interface and Control Logic Cards**

With the exception of the printhead driver board, which is mounted on the print mechanism, the logic chassis contains all the interface and control logic cards. Each card is a separate module that is removable by releasing the holding cams at each end of the card and withdrawing it from the logic chassis. Replacement is done in a reverse manner, slide the cards into the proper position in the chassis and seat it to its connector via the holding cam levers. The logic circuits on these cards perform terminal/printer interface, control and timing, character code decoding, and print mechanism control functions for the printer.

## **Power Supply**

The power supply in the printer consists of an ac input power transformer, a backplane rectifier board, and a dc regulator/power supply board. These components are physically separate from one another, as shown in figure 1-8. The transformer converts either 60-Hz or 50-Hz ac input power to the following ac voltages: 28, 24, 16, and 13 V ac. The backplane board contains rectifiers for producing +36- and +12-V dc power. The power supply board supplies regulated +5 V dc for the logic circuits, and it also contains a -12-V dc rectifier/regulator to produce power for use by the controller, character decoder, and interface circuits of the printer.

## FEATURES SUMMARY LIST

The following is a summary listing of terminal features; some of the features listed have been described earlier in this section and some are given here for the first time.

- Self-contained display module with interface for connecting removable keyboard module.
- 12-inch crt screen using an approximate 7.8-in by 5-in (20-cm by 13-cm) raster area.
- Nonglare crt screen.
- 24 display lines of 80 characters per line.
- Character refresh memory capable of holding all character codes recognizable by the terminal.
- Display-character refresh rate of either 50 or 60 Hz (power-line input frequency) for flicker-free viewing.
- Blinking cursor to mark position of next character entry.
- Highlight feature, permitting operator to display selected data fields either at reduced intensity or blinking.
- Capability of positioning cursor anywhere on display area via keyboard inputs.
- Audible notification at 73rd character position that end of line is approaching.
- Capability of recognizing and generating 128 discrete codes: 95 alphanumeric codes and 33 control codes.
- Alphanumeric and control-character codes that correspond with those recommended by ANSI.
- Modular keyboard assembly interconnected to display module via single interface cable.
- 80-key keyboard with 67-key main cluster and 13-key numeric-entry cluster.
- Nonglare keytops on all keyboard keys.
- Keyboard access to all 33 ASCII control codes.
- Keyboard carries all controls and indicators normally used by the operator during terminal operation.
- 3-character buffer for keyed-in data to prevent typing-burst errors.

- Operator selection of the following via the keyboard:
  - Online or local mode (offline) operation of the terminal.
  - Choice of routing keyed-in data to the communication channel only, to the display and printer only, or to the display, printer, and communication channel.
  - Choice of any two of the following communication line baud rates in addition to a preset 300 baud rate: 110, 150, 200, 300, 600, 1200, 1800, 2400, 4800, or 9600.
  - Odd, even, or no word parity.
  - Page or scroll mode operation of the display data entered via the keyboard.
  - Use of either 96- or 64-character, alphanumeric, ASCII code sets for keyed-in data.
- Keyboard control of display functions including cursor positioning, reset cursor, clear screen, line clear, or highlight.
- Terminal available with either voltage level communication facility interface, or with current loop interface.
- 50-Hz terminals with FTZ approved shielding.
- Rear panel connector for attaching either nonimpact printer for quiet terminal operation, or impact printer for producing up to 5-part multi-copy forms.
- Rear panel test switch for facilitating keyboard display terminal test and checkout procedures.

## **EQUIPMENT SPECIFICATIONS**

The following paragraphs describe the environmental, electrical, and physical specifications for the keyboard display terminal, the nonimpact printer, and the impact printer.

## **ENVIRONMENTAL SPECIFICATIONS**

All of the terminal equipments have the following environmental requirements.

- Operating
  - Temperature: +50° to +104°F (+10° to +40°C)
  - Temperature Change: 18°F (10°C) per hour
  - Relative Humidity: 20 to 80% - no condensation
  - Humidity Change: 10% per hour
  - Altitude from Sea Level: -980 to +9850 ft (-300 to +3000 m)
  
- Nonoperating
  - Temperature: -14° to +122°F (-10° to +50°C)
  - Temperature Change: 27°F (15°C) per hour
  - Relative Humidity: 10 to 90% - no condensation
  - Humidity Change: 10% per hour
  - Altitude from Sea Level: -980 to +9850 ft (-300 to +3000 m)

## **KEYBOARD DISPLAY ELECTRICAL SPECIFICATIONS**

The keyboard display terminal has the following electrical power requirements.

- 120 V ac, 60 Hz, at 1.0 A, nominal
  
- 220/240 V ac, 50 Hz, at 0.55 A, nominal

The keyboard display terminal requires 90 watts of power and dissipates heat at about 332 Btu/hr.

## **NONIMPACT PRINTER ELECTRICAL SPECIFICATIONS**

The nonimpact printer has the following electrical power requirements.

104 to 127 V ac, 59.0 to 60.6 Hz, single-phase, 2.0 A

or

198 to 242 V ac, 49.0 to 50.5 Hz, single-phase, 1.3 A

216 to 264 V ac, 49.0 to 50.5 Hz, single-phase, 1.3 A

Power use of this printer is 100 watts operating and heat dissipation is 341 Btu/hr.

## **IMPACT PRINTER ELECTRICAL SPECIFICATIONS**

The impact printer has the following electrical power requirements.

104 to 127 V ac, 59.0 to 60.6 Hz, single-phase, 4.2 A

or

198 to 268 V ac, 49.0 to 50.5 Hz, single-phase, 2.1 A

Power use of this printer is 250 watts operating and heat dissipation is 854 Btu/hr.

## **KEYBOARD DISPLAY PHYSICAL SPECIFICATIONS**

The keyboard display terminal has the following dimensions and weight with the keyboard attached, see figure 1-9.

Height: 15.20 in (38.6 cm)

Width: 21.65 in (55.0 cm)

Depth: 20.45 in (51.9 cm)

Weight: 51 lb (23.1 kg)

## **NONIMPACT PRINTER PHYSICAL SPECIFICATIONS**

The nonimpact printer has the following dimensions and weight, see figure 1-10.

Height: 5.94 in (15.1 cm)

Width: 17.62 in (44.8 cm)

Depth: 15.94 in (40.5 cm)

Weight: 30 lb (13.6 kg) approximately

## **IMPACT PRINTER PHYSICAL SPECIFICATIONS**

The impact printer has the following dimensions and weight, see figure 1-11.

Height: 14.80 in (37.5 cm)

Width: 27.55 in (70.0 cm)

Depth: 15.00 in (38.1 cm)

Weight: 77 lb (35 kg) approximately

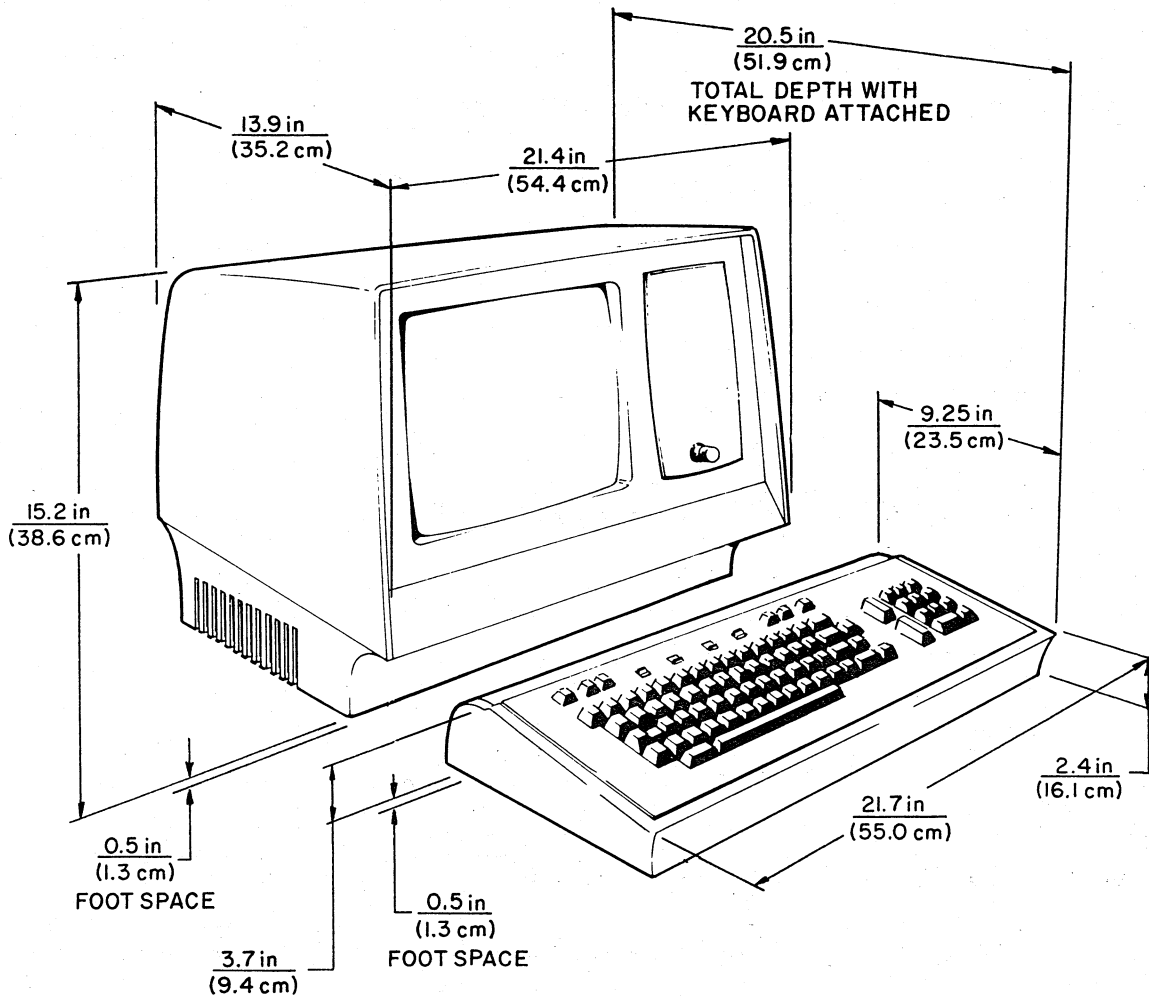

VALUES GIVEN ARE  
MAXIMUM DIMENSIONS

1741-12

Figure 1-9. Keyboard Display Terminal Dimensions

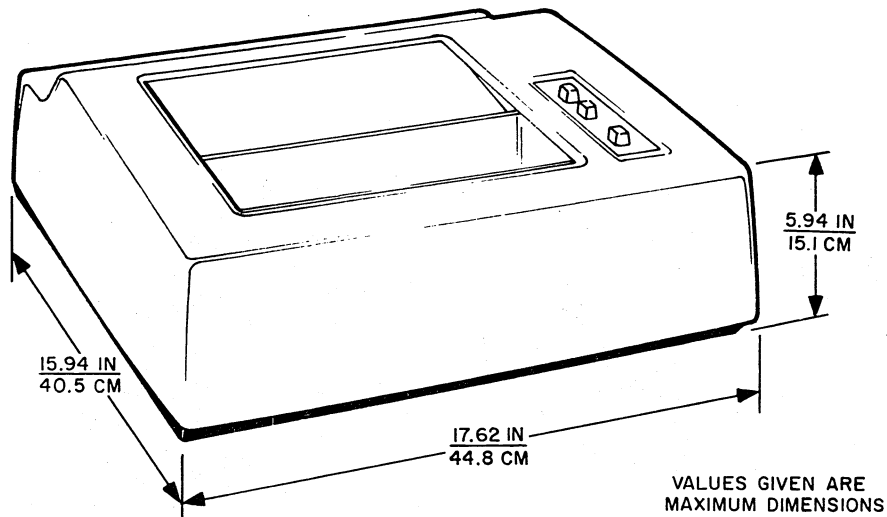

01848-3

Figure 1-10. Nonimpact Printer Dimensions

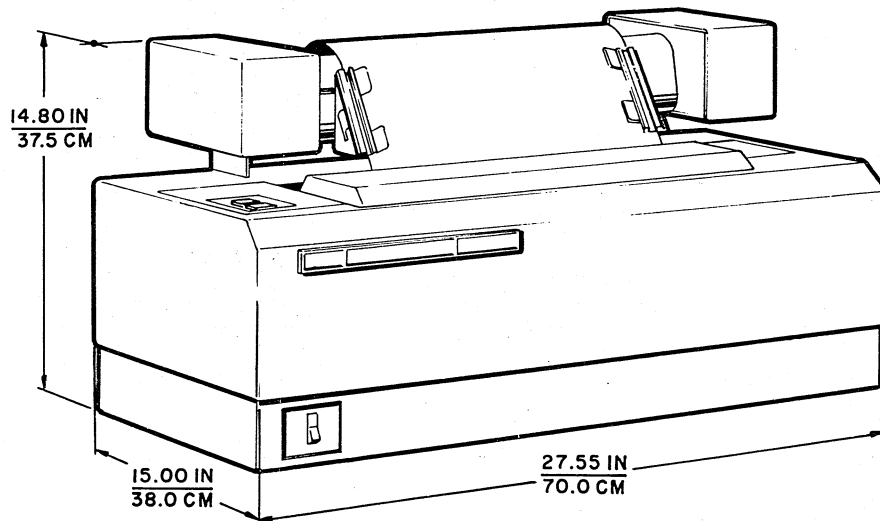

01759-1

Figure 1-11. Impact Printer Dimensions



---

This section describes the controls and indicators, preparation for operation, and terminal operation for the various terminal equipments. The keyboard display, the nonimpact printer, and the impact printer controls and indicators portions of this section describe the locations and functions of the controls and indicators. The preparation for operation portion describes how to prepare each of the terminal equipments for operation and includes information regarding the supplies required for each equipment (such as printer forms, ribbon, etc.). The terminal operation portion of this section provides setup information for the various operating modes of the terminal and gives brief examples of typical terminal operations.

## KEYBOARD DISPLAY CONTROLS AND INDICATORS

The following text divides the description of the keyboard display controls and indicators into three major parts: internal controls, external controls, and keyboard data entry and control keys. Internal controls are those used principally by terminal maintenance personnel during installation and checkout of the terminal. These internal controls are described here, because of the manner in which some affect functions of the keyboard display terminal or modify the functions of its external controls. The external controls are used by the terminal operator to set up the terminal for operation and to select its desired mode of operation. The keyboard data entry and control keys are used during terminal operation.

### INTERNAL CONTROLS

The internal controls consist of switches and jumpers inside the terminal that are used principally during terminal installation and maintenance. With the exception of video monitor adjustments, all internal controls are located on the control logic PC board inside the display module enclosure. To gain access to these controls, remove the two cabinet hood retaining screws, see figure 2-1, and lift off the cabinet hood. Figure 2-2 shows the location of the controls on the PC board and indicates how they are set to obtain a desired condition.

A decal, similar in appearance to figure 2-2, is carried on the logic PC board chassis inside the terminal. The FACTORY boxes on the decal carry Xs indicating the initial switch settings made at the factory. The SITE boxes should be Xed during installation to reflect the switch settings used for a particular terminal installation.

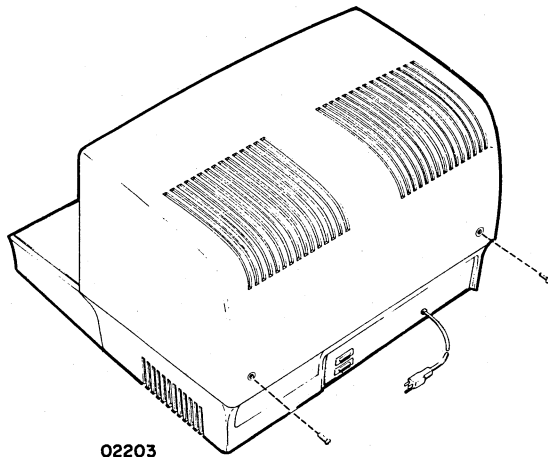

Figure 2-1. Cabinet Hood Removal

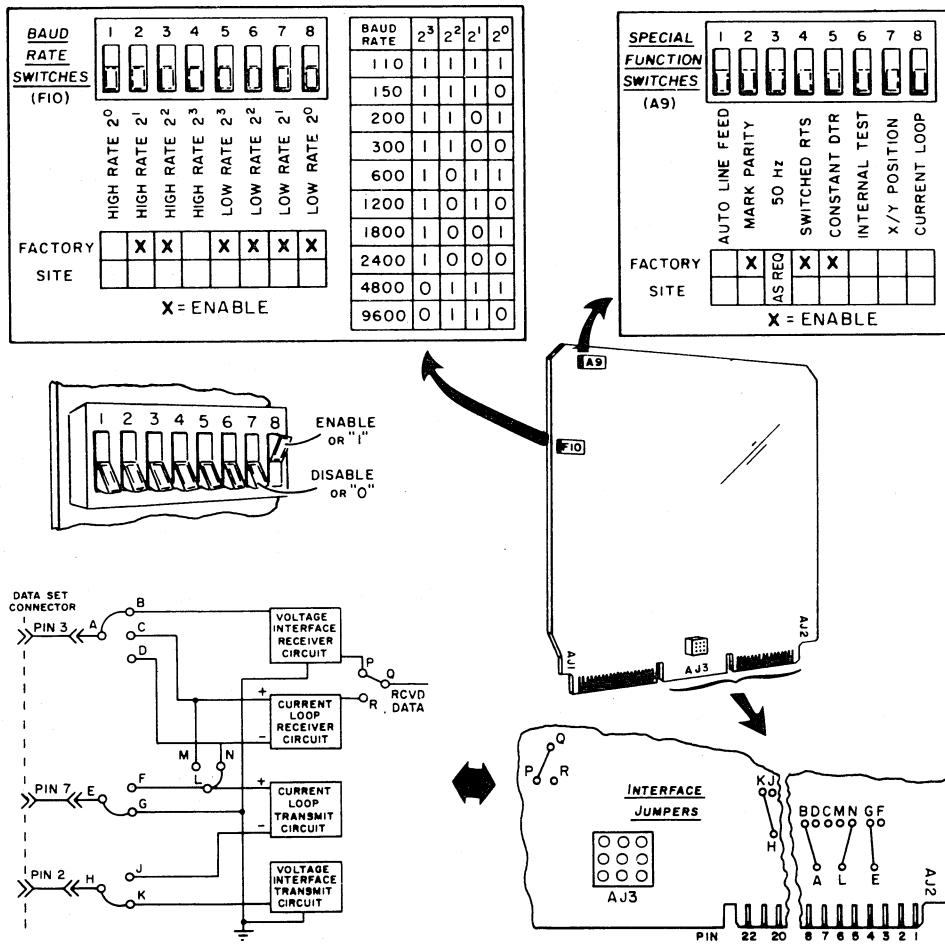

Figure 2-2. Internal Switches and Jumpers

## **BAUD RATE Switches**

There are eight BAUD RATE switches in the terminal. These eight switches consist of four HIGH RATE and four LOW RATE switches. Each group of four switches is associated with the corresponding position of the HIGH RATE/300/LOW RATE switch on the keyboard, and each group of four can be set to give a communication line baud rate of 110, 150, 200, 300, 600, 1200, 1800, 2400, 4800, or 9600. That is, both groups may be set for equivalent or different baud rates, so the rate enabled by each group becomes selectable via the corresponding HIGH RATE or LOW RATE position of the keyboard HIGH RATE/300/LOW RATE switch.

## **AUTO LINE FEED Switch**

When the AUTO LINE FEED switch is in the enable position, performing a carriage return operation automatically causes a line feed operation to occur and moves the cursor to the left margin. When this switch is in the disable position, a carriage return operation simply moves the cursor to the left margin without performing a line feed.

## **MARK PARITY Switch**

The MARK PARITY switch is used in conjunction with the keyboard ODD PAR/NO/EVEN PAR switch. It is used to determine whether a mark or a space is transmitted in the parity bit position of a data word when the keyboard switch is in the NO position (that is, word parity is disabled). When the MARK PARITY switch is in the enable position, a mark is transmitted in the parity bit location; and when the switch is in the disable position, a space is transmitted in the parity bit location.

## **50 Hz Switch**

The 50 Hz switch is used to roughly match the refresh rate of the display to the frequency of the input power line (50 or 60 Hz); fine frequency adjustment is accomplished automatically via a phase-lock-loop circuit. In the enable position, this switch selects a 50-Hz refresh rate; in its disable position, this switch selects a 60-Hz refresh rate.

## **SWITCHED RTS Switch**

The SWITCHED RTS switch selects between a constant and a switched Request to Send (RTS) signal in terminals using a voltage level communication channel (using modems). When the constant position is selected (in the disable position), the RTS

signal remains on as long as both the Data Set Ready and Data Terminal Ready signals remain on. When switched operation is selected by placing the switch in the enable position, the on state of the RTS signal depends on whether the terminal is operating in full- or half-duplex mode.

- In full-duplex mode, the RTS signal goes on at the first keystroke and remains on until the terminal is either switched to local mode operation or switched to current loop mode operation.
- In half-duplex mode, the RTS signal goes on at the first keystroke and goes off a minimum of 1 millisecond after transmission or reception of a carriage return code (CR 015g), an end of text code (ETX 003g), an end of transmission code (EOT 004g), or a line feed code (LF 012g). It also goes off: 1) upon switching to local mode operation, 2) following reception of a break code (any word with a space in its stop-bit position), or 3) upon switching to current loop mode operation.

### **CONSTANT DTR Switch**

The CONSTANT DTR switch selects between a constant and a switched Data Terminal Ready (DTR) signal in terminals using a voltage level communication channel (using modems). When the constant (enable) position is selected, the DTR signal remains on at all times that the terminal power is on. When the switched (disable) position is selected, the DTR signal is on at all times that the terminal is in online mode and terminal power is on, and is off when the keyboard ONLINE/LOCAL switch is in the LOCAL position.

### **INTERNAL TEST Switch**

Placing the INTERNAL TEST switch in the enable position causes the terminal to store and display all codes (data and control) received on the communication interface. Received cursor control or editing control codes do not perform their usual function; rather, they are simply stored and displayed. The generation of keyboard control codes may also be checked with this switch in its enable position. Display graphics for both alphanumeric and control codes are given in section 4, Codes and Character Sets. Placing this switch in its disable position (normal), permits normal operation of the display.

## **X/Y POSITION Switch**

The X/Y POSITION switch is only active when the display is operating in page mode (that is, not in scroll mode). When this switch is in its enable position, it causes the terminal to interpret the two codes immediately following an escape and numeric 1 sequence (033<sub>g</sub> and 061<sub>g</sub>) as X-Y positioning codes. The first code following the 033<sub>g</sub>-061<sub>g</sub> sequence is interpreted as an X-positioning code, which has a legal range of 040<sub>g</sub> to 157<sub>g</sub>. The second code received is interpreted as a Y-positioning code and it has a legal range of from 040<sub>g</sub> through 067<sub>g</sub>. These ranges correspond with character positions 1 through 80 of a line and lines 1 through 24 of a display page, respectively. The X-Y positioning feature of the terminal is not active when the X/Y POSITION switch is in the disable position.

## **CURRENT LOOP Switch**

On terminals with a current loop interface, the CURRENT LOOP switch conditions the terminal for use on a current loop communication facility by causing it to disregard or inhibit RS-232-C/CCITT V.24 modem control signals. Moving the switch to its enable position conditions a current loop terminal for use on a current loop communication facility. Moving the switch to its disable position causes the terminal to require RS-232-C/CCITT V.24 modem control signals for proper operation, and therefore, the disable position switch is recommended for conditioning a voltage level terminal for use on a voltage level communication facility.\*

## **Interface Jumpers**

The interface jumpers (refer to figure 2-2) condition the terminal for connection to different types of communication facilities. A unipolar, full-duplex, current loop facility connection is made by jumpering the following pairs of jumper connectors together: A to D, E to F, H to J, R to Q, and L to M. A unipolar, half-duplex, current loop facility connection is made by jumpering A to C, H to J, R to Q, and L to N. A voltage level interface for terminals using modems is implemented by jumpering: P to Q, H to K, A to B, L to M, and E to G. Operation of a voltage level terminal in either full- or half-duplex mode is determined by the type of modem used and by connections made externally on the communication-channel side of the modem. Although all terminals have these jumper connectors, the jumper connections for current loop channels are only effective in terminals having current loop capabilities; refer to the table in section 1 entitled Available Terminal Configurations.

---

\* Some low-cost modems may not supply all the necessary RS-232-C/CCITT V.24 interface signals. In such cases, operation of the terminal with the current loop switch in the enable position may be necessary.

## EXTERNAL CONTROLS

As noted in section 1, the display terminal has external (operator) controls located on the keyboard and the front panel, see figure 2-3, and on the rear panel, see figure 2-4. The following text identifies these external controls, gives their location, and defines their function.

### INTENSITY Control

The INTENSITY control is located on the front panel of the display module, just to the right of the display screen. Its function is to permit the terminal operator to adjust the video intensity of the display to suit ambient lighting conditions.

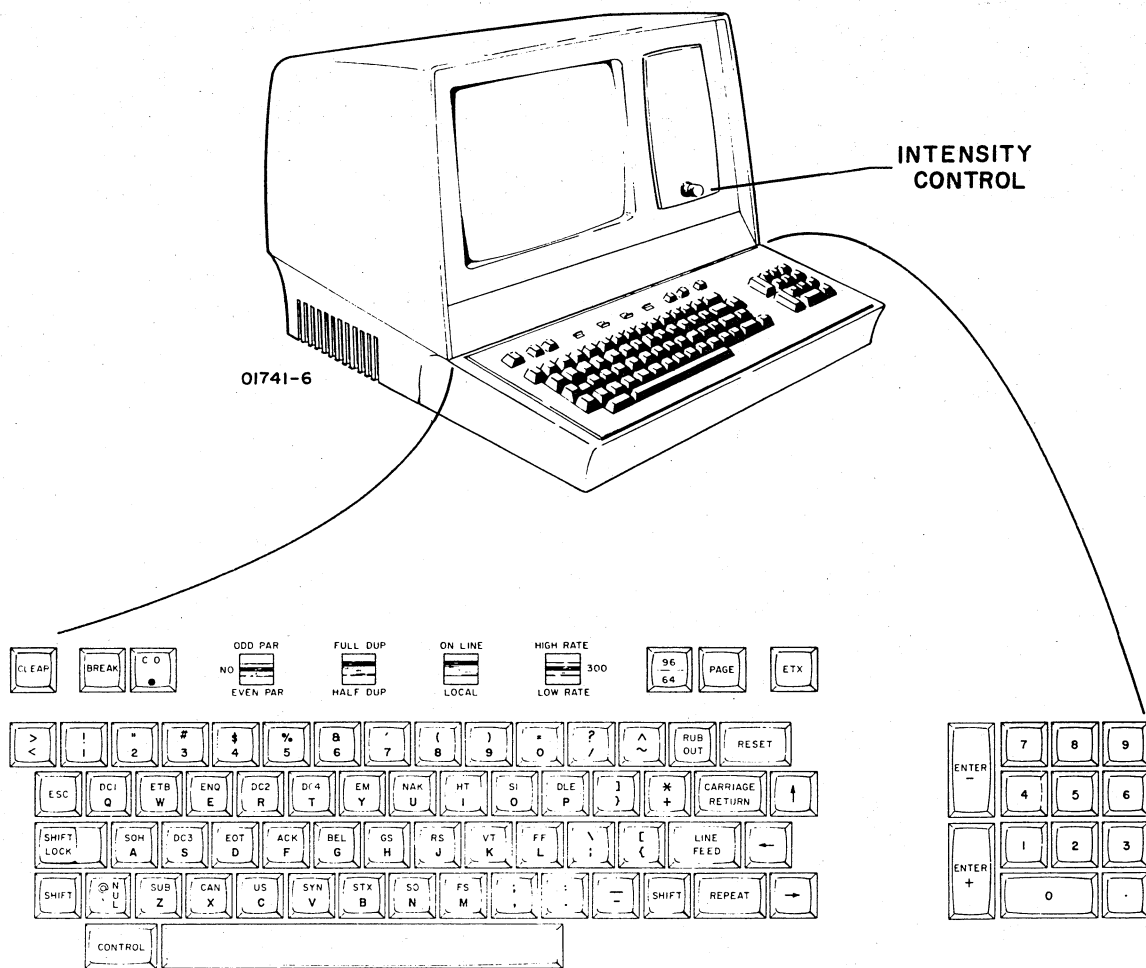

01499-6

Figure 2-3. External Controls, Keyboard and Front Panel

## **CO Indicator**

The CO indicator is located in the upper row of keys on the keyboard module. In terminals using modems, this indicator lights to indicate the presence of both the Received Line Signal Detector and Data Set Ready signals. Both signals are necessary to receive information from a distant station unless the CURRENT LOOP switch is enabled.

## **ODD PAR/NO/EVEN PAR Switch**

The ODD PAR/NO/EVEN PAR switch is a three-position toggle switch located in the upper row of keys on the keyboard module. Placing this switch in the EVEN PAR position causes bit 2<sup>7</sup> of a transmitted word to be set to even parity and bit 2<sup>7</sup> of a received word to be checked for even parity. Placing the switch in the ODD PAR position causes the terminal to perform odd-parity checking and generation. Parity error detection causes a parity error symbol (■) to display on the crt screen in place of the character containing the error.

When the switch is set to the central (NO) position, the parity bit (2<sup>7</sup>) of a transmitted word is set to either a marking or a spacing condition, depending on the position of the internal MARK PARITY switch. Received words are not checked for parity when the switch is in the NO position.

## **FULL DUP/HALF DUP Switch**

The FULL DUP/HALF DUP switch is a two-position toggle switch located in the upper row of keys on the keyboard module. The two positions of this switch alter routing of keyboard data within the terminal. They do not affect or alter communication channel operation (other than the Request to Send signal; see SWITCH RTS Switch, preceding) or the communication channel connections.

When the switch is in the FULL DUP position and the terminal is online, keyed-in information passes only to the transmit interface and does not go to the display memory for display. This switch position is for use on communication channels employing echo checking\* for printing or displaying keyed-in information. Received information is the only information displayed when the switch is in the FULL DUP position.

---

\* Echo checking means information keyed-in at a terminal is transmitted to a receiving station and is echoed back to the sending terminal for display or printing as received data. Echo checking is primarily used to verify data transmission on full-duplex (two-way simultaneous) communication channels. Incorrect positioning of the FULL DUP/HALF DUP switch is indicated when a keyed-in character produces either a double-character displayed or no character display.

When the switch is in the HALF DUP position and the terminal is online, keyed-in information passes to the transmit interface, the display, and the printer interface. Received information has precedence over keyed-in information for display and control purposes, but it does not interfere with the transmission of keyed-in information.

### **ON LINE/LOCAL Switch**

The ON LINE/LOCAL switch is a two-position toggle switch located in the upper row of keys on the keyboard module. When this switch is in the LOCAL position, the terminal passes keyed-in information to the display and to the printer interface, but does not route it to the transmit interface. Whether the terminal accepts receive information in local mode depends on the position of the internal CONSTANT DTR switch. If a constant DTR signal is enabled, receive information is accepted and then displayed and printed; if the constant DTR signal is disabled, the communication facility interface is disabled and data may be neither sent nor received.

When the ON LINE/LOCAL switch is in the ON LINE position, the terminal is enabled for online communications and the communication facility interface becomes subject to conditioning by other keyboard and internal controls and switches.

### **HIGH RATE/300/LOW RATE Switch**

The HIGH RATE/300/LOW RATE switch is a three-position toggle switch located in the upper row of keys on the keyboard module. The switch permits the operator to select one of three transmission line baud rates. The baud rates for the high and low positions of the switch are selected at the time of terminal installation from among the following: 110, 150, 200, 300, 600, 1200, 1800, 2400, 4800, or 9600 baud. The 300 position of the switch is preset to a 300-baud rate of transmission.

### **96/64 Switch**

The 96/64 switch is a two-position, pushbutton switch located in the upper row of keys on the keyboard module. When this switch is in the up position, the full 96-character ASCII alphanumeric code set is accessible via the keyboard. When this switch is down, the keyboard code set is restricted to the 64-character ASCII subset and alpha-key actuation generates an uppercase code regardless of shift key positioning. In the 64 position, symbols shown in yellow on the keyboard (~, }, {, \, and |) are not accessible via the keyboard. The positioning of the 96/64 switch does not affect received information.

## PAGE Switch

The PAGE switch is a two-position, pushbutton switch located in the upper row of keys on the keyboard module. When this switch is in the down position, page-mode operation of the display screen is selected. That is, the full display screen is available for the entry of keyed-in data. When this switch is in the up position, scroll-mode operation of the display screen is selected. In scroll mode, the cursor is always on the bottom line of the display (line 24) unless it is moved up by a cursor-control or backspace command. Each time the last line of the display is filled, a line feed operation moves display data in the last line and in each preceding line up one position. The top line of display data (line 1) scrolls off the screen and is lost. When in scroll mode, the X/Y positioning commands are not accepted, (see the preceding description, X/Y POSITION Switch).

## CB1 Switch

The CB1 switch is the circuit breaker located on the rear panel of the terminal. This circuit breaker also serves as the on/off and master clear switch for the display terminal. Terminal power is off when the circuit breaker is down, and on when the circuit breaker is up. Whenever power is applied to the terminal by moving the CB1 switch up, the terminal performs a power-on, master clear operation to reset all of its logic circuits.

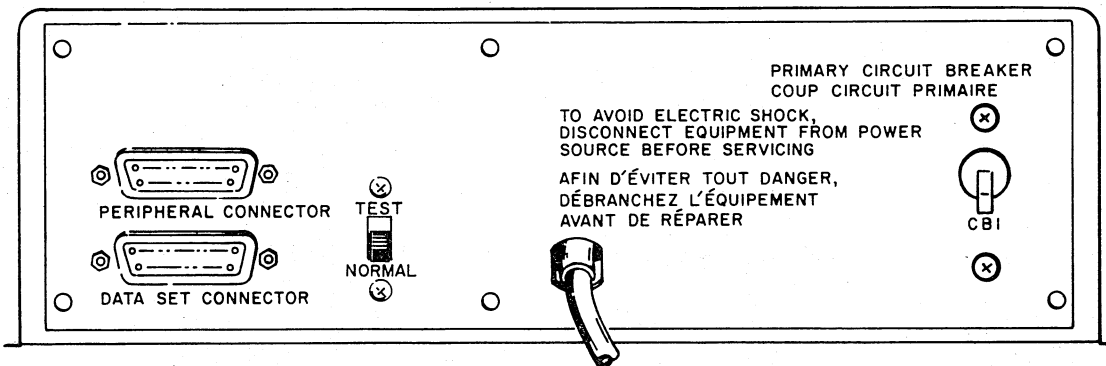

02143

Figure 2-4. External Controls, Terminal Rear Panel

## TEST/NORMAL Switch

The TEST/NORMAL switch is located on the rear panel of the terminal adjacent to the peripheral and data set connectors. This switch is used for test purposes and is left in its NORMAL position for normal terminal operation. When moved to the TEST position, the switch disconnects the terminal from the communication facility and loops the transmit/receive interface of the terminal back on itself for the purpose of checking the operation of the terminal without reliance upon the quality of the communication channels.

Moving the TEST/NORMAL switch to its TEST position makes the following loop-back connections at the terminal interface. Refer to the table, Voltage Level Channel Interface Connector Pin Assignments, listing data set connector pin assignments in section 1.

- Transmitted Data line loops back to Received Data line.
- Request To Send line loops back to Clear To Send line.
- Data Terminal Ready line loops back to Data Set Ready line.
- Data Terminal Ready line loops back to Received Line Signal Detector (carrier-on) line.

#### NOTE

The Data Terminal Ready and Secondary Request to Send lines from the terminal to the communication-facility equipment (modems) are maintained with the TEST/NORMAL switch in TEST. Information may still be sent by the central processor unit even though the terminal cannot receive the information. For this reason, the TEST position of the switch should only be used when online activity is not required.

The TEST/NORMAL switch makes the indicated data set connector pin connections regardless of the terminal type (voltage level or current loop); however, in current loop terminals, the test switch becomes inoperative due to disconnection of the external current source.

#### KEYBOARD DATA ENTRY AND CONTROL KEYS

The shaded-in areas of the keyboard, as shown in figure 2-5, show controls described earlier in this section. Most of the remaining keys on the keyboard provide operator entry of data and/or control codes. Some of the keys perform special functions and are described in greater detail. Specifically discussed in the following paragraphs are: the CLEAR, BREAK, ESC, SHIFT LOCK, SHIFT, and CONTROL keys near the left side of the keyboard, and the ETX, RUB OUT, CARRIAGE RETURN, cursor positioning ↑, ←, and ↓ keys, RESET, LINE FEED, REPEAT, ENTER-, and ENTER+ keys near the right side of the keyboard. The CONTROL key discussion includes all keys on the keyboard that generate an ASCII control code, and not just the keys used in conjunction with the CONTROL key to generate control codes.

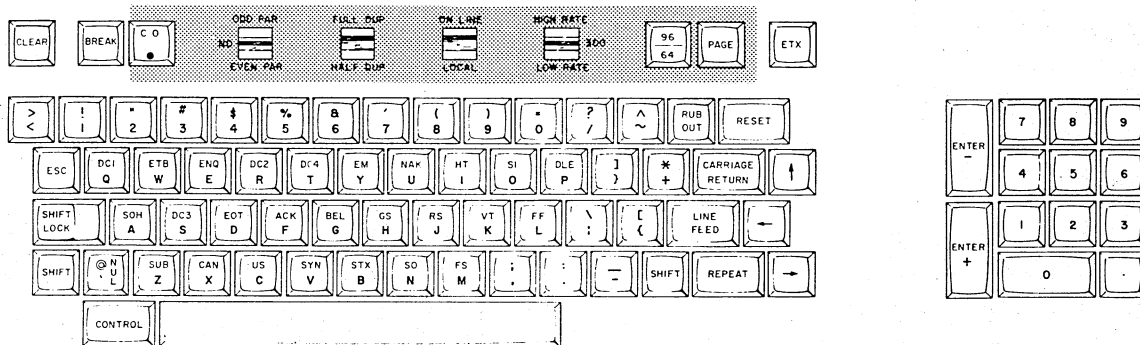

Figure 2-5. Keyboard Key Layout

01499-6

The terminal keyboard is principally a code generating device, in that striking a key produces the code associated with that key. Since the keyboard has less keys than necessary to produce 128 codes on a one-key to one-code basis, it uses the shift keys (SHIFT and SHIFT LOCK) and the CONTROL key to expand its basic code set. The keyboard is a tri-level device and operates in the following modes.

- Lowercase mode, with neither shift nor CONTROL keys actuated, to produce 47 distinct codes.
- Uppercase mode, with either the SHIFT or the SHIFT LOCK key actuated, to produce another 47 distinct codes.
- Control mode, with the CONTROL key actuated, to produce 27 additional codes.

This brings the total number of unique codes available to 121; these 121 codes are supplemented by six fixed code control keys and the space bar to produce the full 128-code set recommended in current ANSI standards. The keyboard has a switch for blocking keyboard access to 31 of the lowercase codes, which limits alphanumeric code generation to the 64-character ASCII subset.

Transmission of any code during online operation of the terminal is accomplished by simply pressing the key(s) required for that code. When a code key is pressed, transmission occurs regardless of the state of the other keys on the keyboard; that is, transmission of a code cannot be blocked by pressing and holding another code key down. Lists of codes and their associated symbols are included in section 4 of this manual.

The special-function and control-code keys found on the keyboard are described in the following paragraphs.

## **CLEAR Key**

Pressing the CLEAR key clears the entire display screen and memory, resets the cursor to home position, and places an ASCII CAN code (030<sub>g</sub>) on the Transmitted Data line.

## **BREAK Key**

Actuation of the BREAK key causes the Transmitted Data signal to go to a spacing condition between 182 and 338 milliseconds. This signal indicates that for some reason, the terminal is breaking off communications. The BREAK key, therefore, should be used only as directed at the system level.

Receipt of a break signal by the terminal sounds the audible alarm for approximately 200 milliseconds and causes the display of a parity error symbol (■) as an indication that a break signal or a word with a framing error (incorrect stop bit) has been received.

## **ESC Key**

Pressing the ESC key encodes and transmits an ASCII ESC code (033<sub>g</sub>) on the Transmitted Data line during normal terminal operation.

## **SHIFT LOCK Key**

The SHIFT LOCK key functions in much the same manner as an ordinary typewriter shift lock key. Pressing this key locks it down and enables access to uppercase characters and symbols on the keyboard (level 2 operation). Pressing this key again, when it is locked, releases it and permits access to the lowercase characters and symbols on the keyboard (level 1 operation).

The action of the SHIFT LOCK key is overridden when the 96/64 switch is in position 64. In this instance, all lowercase alpha characters as well as the five symbols colored in yellow on the keyboard (~, }, {, ` , and |) are not accessible via the keyboard. The SHIFT and SHIFT LOCK keys still access the uppercase special characters on the upper row of keys (numeric row) in the normal manner.

## **SHIFT Keys**

With the exception that they are nonlocking and are only active when held down, both SHIFT keys on the keyboard function in the same manner as the SHIFT LOCK key.

## **CONTROL Key**

The CONTROL key is used to access level 3 operation of the keyboard, generation of ASCII control codes. Although only 27 of the 33 ASCII control codes are actually accessed via the CONTROL key, the following text discusses keyboard access of all 33 ASCII control codes.

Understanding the function and operation of the various control code keys on the keyboard is important because of their varying actions. Some of the keys have a fixed code associated with them and are active at all times, while most of the keys are normal character keys and only become control code keys when actuated in conjunction with the CONTROL key. Additionally, some of these keys move the cursor or otherwise affect the display.

The following text arbitrarily divides the control code keys into four groups: CONTROL plus keys, fixed code keys, cursor movement keys, and special CONTROL key functions. These divisions are arbitrary because they often overlap; they do, however, serve to distinguish between the different types of control code keys.

### **CONTROL Plus Keys**

The CONTROL key is used in conjunction with the 27 character keys carrying ASCII control code mnemonics (26 alpha keys and NUL key) to permit encoding and transmission of the codes associated with those mnemonics. To transmit a control code in this manner, the CONTROL key is first pressed and held while the desired control code key is pressed. This action transmits the control code associated with a character key regardless of the positioning of the SHIFT or SHIFT LOCK keys or of the 96/64 switch. Section 4 of this manual contains a listing of the control codes associated with each CONTROL plus key.

### **Fixed Code Keys**

The following text describes 12 keys having a fixed control code function. Six of these keys provide the only means of performing their associated function. The remaining six can also be encoded via the CONTROL plus character key method.

As noted previously, 27 control codes can be accessed via the CONTROL plus character key method. The additional six required to complete the set of 33 ASCII control codes are directly associated with a fixed code key. The key names for these fixed code keys are as follows; and if the key name differs from the ASCII mnemonic, a key appears in parentheses following the key name.

- ETX
- ESC
- LINE FEED (LF)
- RUB OUT (DEL)
- CARRIAGE RETURN (CR)
- ← (BS)

The following six fixed code keys have codes that may also be accessed via actuation of the CONTROL key plus a character key.

<u>Fixed Code Key</u>	<u>ASCII Mnemonic</u>	<u>Equivalent</u>
CLEAR	CAN	CONTROL plus X
RESET	EM	CONTROL plus Y
↑	SUB	CONTROL plus Z
→	NAK	CONTROL plus U
ENTER-	FS	CONTROL plus M
ENTER+	GS	CONTROL plus H

#### Cursor Movement Keys

The following control code keys move the cursor and/or affect the display in some manner. Functions associated with these control code keys are described elsewhere in this section. The purpose of this listing is simply to define the group of control code keys that move the cursor or otherwise affect the display. The list includes the key names or symbols, the ASCII mnemonics for the codes transmitted, and brief descriptions of the functions the keys perform. Note that most of the keys in this list have already appeared in preceding lists.

<u>Keys</u>	<u>ASCII Mnemonic</u>	<u>Function</u>
LINE FEED	NL	Moves cursor down a line
CARRIAGE RETURN	CR	Returns cursor to left margin (AUTO LINE FEED switch disabled)
←	BS	Backspaces cursor
CLEAR	CAN	Clears display and resets cursor
RESET	EM	Resets cursor without affecting already displayed data
↑	SUB	Moves cursor up a line
→	NAK	Moves cursor forward
CONTROL plus V	SYN	Clears a line from cursor to end of line; cursor does not move
CONTROL plus N	SO	Initiates reduced intensity and advances cursor one space
CONTROL plus O	SI	Ends reduced intensity or blink (highlight) field and advances cursor one space
CONTROL plus W	ETB	Initiates blink and advances cursor one space

#### Special CONTROL Key Functions

The following four functions can only be accessed by first pressing and holding the CONTROL key and then pressing the appropriate character key. The first function described is a line clear function, and the remaining ones are associated with the highlight feature of the terminal. Although all have been noted in the preceding list, they are more thoroughly described here due to their special functions and because their only access is by way of the CONTROL key.

Line Clear — Pressing and holding the CONTROL key down and then pressing the V character (SYN) key during normal online operation of the terminal places an ASCII SYN code (026g) on the Transmitted Data line. This same entry also clears a display line from the current cursor position up through the end of the line. The cursor does not move during this operation.

Initiate Low Intensity — Pressing and holding the CONTROL key down and then pressing the N character (SO) key during normal online operation of the terminal places an ASCII SO code (016g) on the Transmitted Data line. At this same time, the cursor is advanced one position and subsequently, characters are entered on the display at a reduced intensity. The reduced intensity effect includes all characters in a line from the character position following the CONTROL plus N entry up to a CONTROL plus O entry (end highlight) or the end of the line, whichever occurs first.

End Highlight — Pressing and holding the CONTROL key down and then pressing the O character (SI) key during normal online operation of the terminal places an ASCII SI code (017g) on the Transmitted Data line. At the same time, this action designates the end of an already initiated highlight field (reduced intensity or blink) in the same line and advances the cursor one character position.

Either an end of line condition (cursor moves to 80th position of a line) or an end highlight keyboard entry, whichever occurs first, terminates a highlight field (either low intensity or blink).

Initiate Blink — This control entry designates the beginning of a blink field. The entry causes subsequent character entries to blink from normal to reduced intensity approximately two times a second. A blink entry is made by pressing and holding the CONTROL key and then pressing the W character (ETB) key. This action places an ASCII ETB code (027g) on the Transmitted Data line, advances the cursor one character position, and initiates the blink field. Terminating a blink field is normally the same as terminating a reduced intensity field; it is usually terminated by way of either an end highlight command or an end of line condition. A reduced intensity command will also terminate a blink field; however, this entry will end the blink field, advance the cursor one position, and initiate a reduced intensity field. A blink command will not terminate a reduced intensity field.

### **ETX Key**

Pressing the ETX key during normal online operation of the terminal places an ASCII ETX code (003g) on the Transmitted Data line (data on the display screen is not affected).

### **RUB OUT Key**

Pressing the RUB OUT key during normal online operation of the terminal places on ASCII DEL code (177g) on the Transmitted Data line (data on the display screen is not affected).

## **CARRIAGE RETURN Key**

Pressing the CARRIAGE RETURN key during normal online operation of the terminal places an ASCII carriage return code (015<sub>g</sub>) on the Transmitted Data line and moves the cursor back to the left side of the display screen. If the internal AUTO LINE FEED is in the enable position, the carriage return operation automatically causes a line feed operation to occur.

## **Cursor Positioning ( ↑ , ← , and → ) Keys**

Although the RESET, CARRIAGE RETURN, and LINE FEED keys are also cursor positioning keys, only the Cursor Up (↑), Backspace (←), and Skip (→) keys are described here.

### **Cursor Up (↑)**

Pressing the Cursor Up (↑) key during normal online operation of the terminal places an ASCII SUB code (032<sub>g</sub>) on the Transmitted Data line and moves the cursor up one line in its same relative horizontal position without affecting any displayed data. If the cursor is in the first display line when the Cursor Up key is pressed, it moves to the same relative horizontal position in line 24.

### **Backspace (←)**

Pressing the Backspace key (←) during normal online operation of the terminal places an ASCII BS code (010<sub>g</sub>) on the Transmitted Data line and moves the cursor back a space without affecting any displayed information. If the cursor is in home position, it wraps around to the last character position on the screen when the Backspace key is pressed. If the cursor is in the first character position of a line, it moves back to the last character position of the preceding line.

### **Skip (→)**

Pressing the Skip (→) key during normal online operation of the terminal places an ASCII NAK code (025<sub>g</sub>) on the Transmitted Data line and advances the cursor a space without affecting any displayed information. If the cursor is in the last character position of the screen when the Skip key is pressed, it moves to home position (page mode) or causes the display to scroll (scroll mode). If the cursor is in the last character position of a line, it moves to the first character position of the succeeding line.

## **RESET Key**

Pressing the RESET key during normal online operation of the terminal places an ASCII EM code (031<sub>g</sub>) on the Transmitted Data line and moves the cursor back to home position without affecting any already displayed information.

## **LINE FEED Key**

Pressing the LINE FEED key during normal online operation of the terminal places an ASCII NL code (012<sub>g</sub>) on the Transmitted Data line and moves the cursor down one line in the same relative horizontal position without affecting any already displayed information. If the cursor is in the last line of the screen (line 24) when the LINE FEED key is pressed, it wraps around to the same relative horizontal position in the first line (line 1) of the screen or causes a scroll operation (scroll mode).

## **REPEAT Key**

The REPEAT key permits any keyboard character or symbol to be repeatedly displayed at a rate of approximately 15 characters per second in the local mode of terminal operation, or at a rate not greater than the communication line baud rate during online operation of the terminal.

To repeat any character in this manner, press and hold the REPEAT key and then press the key(s) required for the character or symbol to be repeated. Releasing the REPEAT key stops the repeat function.

## **ENTER- Key**

Pressing the ENTER- key during normal online operation of the terminal places an ASCII FS code (034<sub>g</sub>) on the Transmitted Data line; the display is not affected.

## **ENTER+ Key**

Pressing the ENTER+ key during normal online operation of the terminal places an ASCII GS code (035<sub>g</sub>) on the Transmitted Data line; the display is not affected.

## **NONIMPACT PRINTER CONTROLS AND INDICATORS**

The operator controls of the nonimpact printer are located on top of the unit and under the paper cover, see figure 2-6. The following paragraphs describe the non-impact printer controls and indicators.

## ON SWITCH INDICATOR

The ON switch, located in front on top of the printer, is used to apply or remove power from the printer. Pressing the switch to its down position applies power to the printer. The switch is illuminated at all times that power is turned on. Pressing the switch a second time, turns the printer off and returns the switch to its up position.

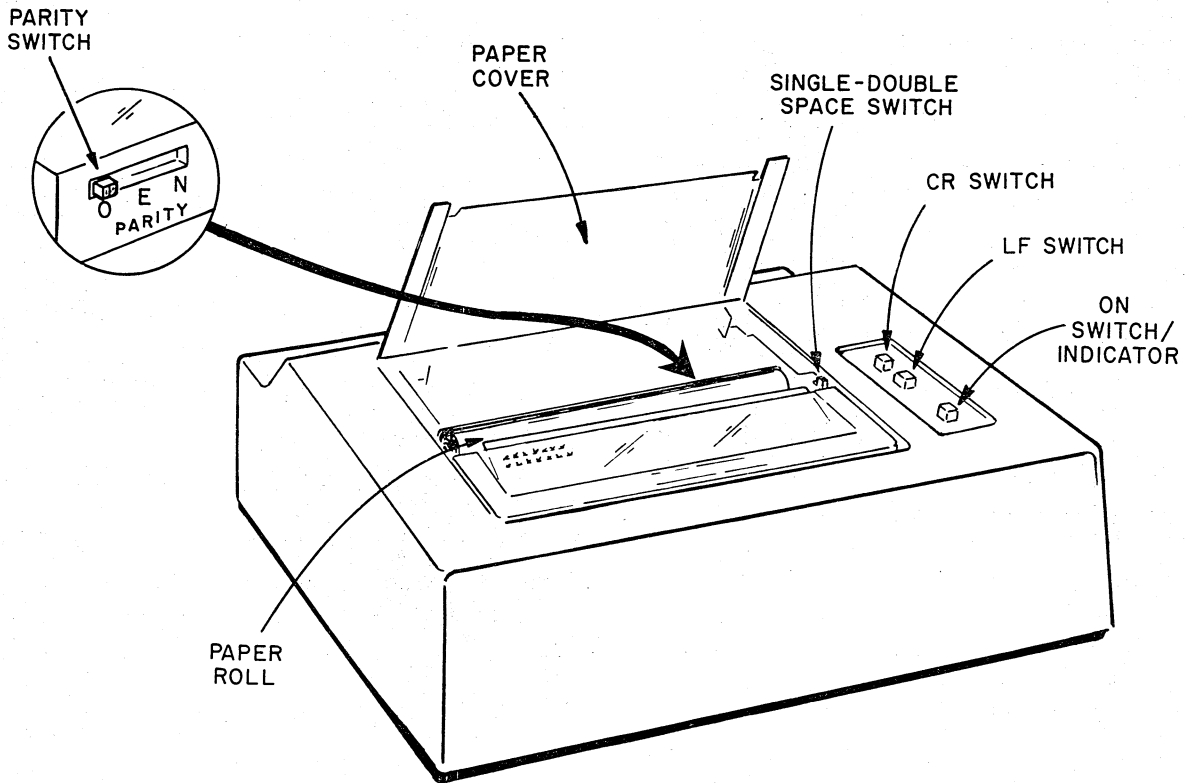

Figure 2-6. Nonimpact Printer Controls and Indicators

## PARITY SWITCH

The PARITY switch is a three-position slide switch located under the paper cover at the front of the paper supply cavity. Sliding the switch to O selects odd parity checking; sliding it to E selects even parity checking; and sliding it to N selects no parity checking. The selection made must coincide with the type of parity used in communications. Parity selection causes the symbol (i) to display on the crt screen.

## LF SWITCH

The LF (line feed) switch, located on top of the printer, provides a continuous line feed when pressed. Releasing the switch causes the line feed operation to halt and returns the switch to its up position.

## CR SWITCH

The CR (carriage return) switch, located on top of the printer, initiates a carriage return function. The printhead returns to column one, but an automatic line feed is not performed.

## SINGLE-DOUBLE SPACE SWITCH

The single-double space switch is the two-position slide switch located under the paper cover to the right of the paper supply cavity. Sliding the switch toward the back of the printer selects single-line spacing, and sliding the switch toward the front selects double-line spacing.

## IMPACT PRINTER CONTROLS AND INDICATORS

The locations of the operator controls and indicators on the impact printer are shown in figure 2-7. To operate the printer properly, it is necessary for the operator to fully understand the function of the switches, indicators, and various operator adjustments provided on the printer. The switches and indicators provided are the ON/OFF switch, the START/STOP switch and the FORM FEED switch. The operator adjustments provided include the Forms Positioning knobs, the Forms Density control, and the horizontal positioning of the tractors.

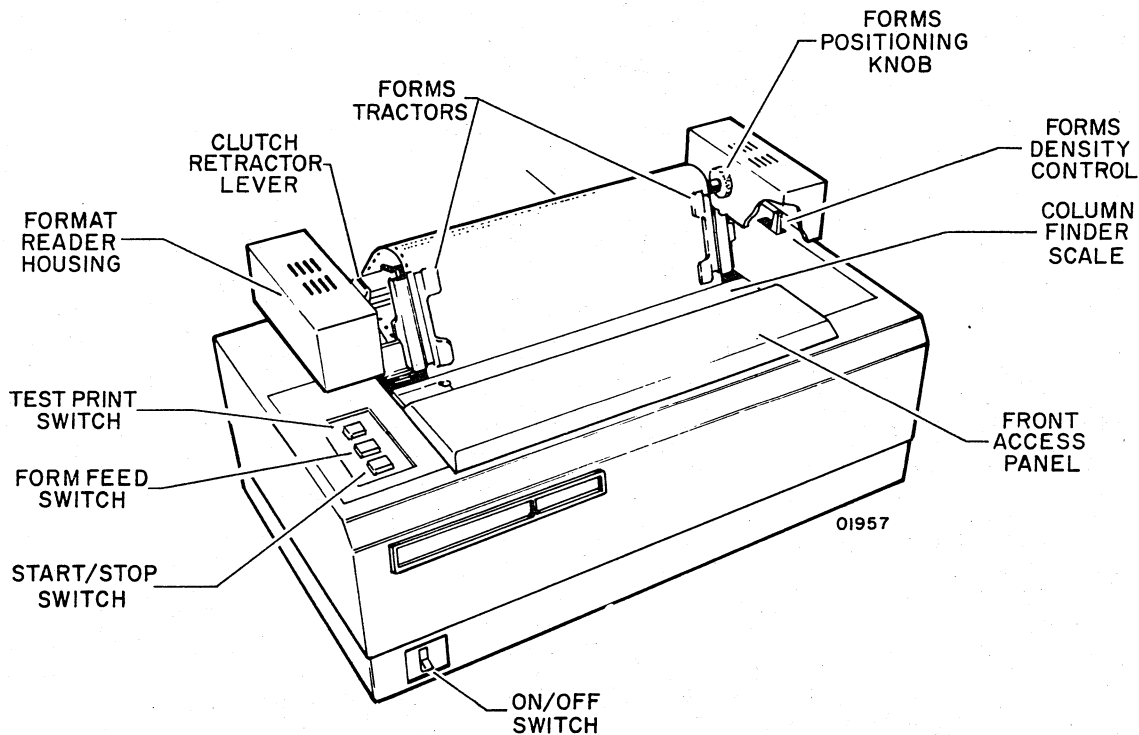

Figure 2-7. Impact Printer Controls and Indicators

## **ON/OFF SWITCH INDICATOR**

The ON/OFF switch, located in the lower-left front corner of the printer, is used to apply or remove power from the printer. The switch is illuminated at all times that power is turned on. When the printer is initially turned on, the switch causes a master clear operation that clears all of the logic circuitry in preparation of operation. If the switch is actuated a second time, the printer is turned off.

## **START/STOP SWITCH INDICATOR**

The START/STOP switch, located on the top-left corner of the printer, is used to place the printer online or offline to the data source. This switch is illuminated whenever the printer is in an online (start) condition. It remains illuminated until the switch is actuated a second time and the printer goes to an offline (stop) condition. If the printer is printing, the transition from online (start) to offline (stop) is delayed until the print operation is complete. Also, if the printer cover is not closed, an interlock switch prevents placing the printer in the online (start) condition.

## **FORM FEED SWITCH**

This momentary action switch, located on the top-left front corner of the printer, causes the forms to be advanced until the top of forms channel (format channel one) is detected. This switch is inoperative whenever the printer is in an online (start) condition. The FORM FEED switch should not be actuated while the format reader is open, as this will cause a forms runaway to occur. If this condition is inadvertently initiated, it may be cleared by moving the ON/OFF switch to OFF.

## **TEST PRINT SWITCH**

Pressing this alternate action switch causes the printer to print the character "B" alternating with blanks across the page and then to perform a single line advance. The resulting pattern may be used to check vertical and horizontal alignment of forms. The switch is illuminated while the test print operation is in process and remains illuminated until the switch is pressed a second time to halt the operation.

## **FORMS POSITIONING KNOBS**

There are two forms positioning knobs, one on each end of the tractor shaft. These knobs are used to manually move the forms for installation and alignment. The positioning knobs are used in conjunction with the clutch retractor lever. When pressed, the clutch retractor lever decouples the tractor shaft from the forms advance mechanism. This allows the forms to be moved independently of the forms advance mechanism, facilitating easy forms alignment.

## FORMS DENSITY CONTROL

The forms density control, located below the format reader housing is used to compensate for the difference in thickness of forms used in printing. As the control lever is moved toward the rear of the printer, the gap between the print mechanism and the print surface is increased, allowing the accommodation of heavy weight and multiple part forms. Note that the numbered positions do not correspond to the number of copies being handled, but are intended for operator reference when forms are changed frequently. The forms density control should always be set to provide optimum print quality for the form in use.

## HORIZONTAL FORMS POSITIONING

Horizontal forms positioning is accomplished by manually positioning the friction-held tractors. Pressure applied to the sides of the tractors causes them to be moved horizontally to compensate for different forms widths and desired margin setups. A column guide is provided to aid in horizontal alignment.

## PREPARATION FOR OPERATION

This portion describes the procedures used in preparing the various units comprising a terminal for operation. The procedures include both general check items and specific operator functions (loading forms, etc.) for each unit. The text covers terminal procedures first, then those for the nonimpact printer and impact printer. A list of operator supplies is included at the end of this section.

To help assure proper terminal operation, the operator should run through all the check items for each unit daily, prior to bringing the terminal online. Figure 2-8 serves as a guide in making the checks pertaining to unit interconnection. Specific functions for each device need be carried out only as required.

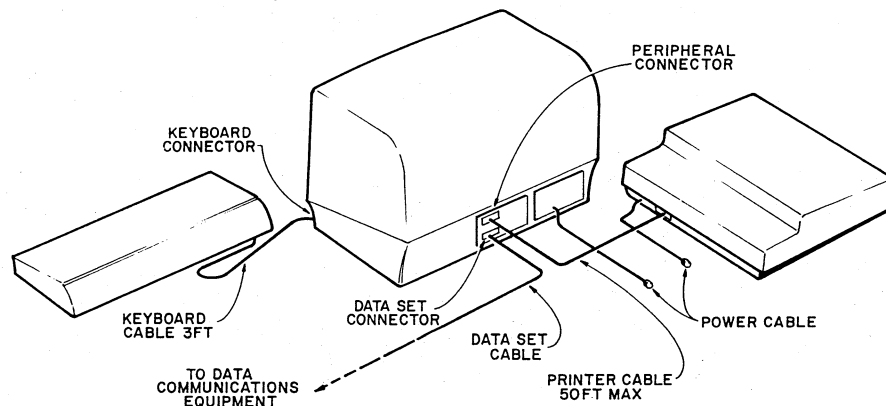

01959

Figure 2-8. Terminal with Printer Option

## DISPLAY TERMINAL

The check items for the display terminal include procedures that should be performed before the terminal is powered-up and procedures for adjustment of the INTENSITY control. The only specific functions for the display terminal are the setting of the mode control, character-set select, parity select, and transmission-rate select switches on the keyboard.

### Check Items

The following constitutes the initial preparation check items for the display terminal.

- 1) Check that all cabling running between the terminal and any external communications device being used is securely fastened to the rear of each unit. At the same time, check the peripheral connector at the rear of the terminal to assure a secure connection. You may tighten any loose connectors or wires, but any wires completely off the connector terminal should be reconnected by terminal maintenance personnel to assure proper connection.
- 2) Check that ac power cords for the terminal and external communication devices are plugged into their proper outlets.
- 3) If the entire terminal is connected to a single, switched ac power line, switch the power line on at this time.
- 4) If desired, detach the keyboard from the terminal and position it for comfortable operation. Refer to figure 2-9 for the correct method of detaching the keyboard.

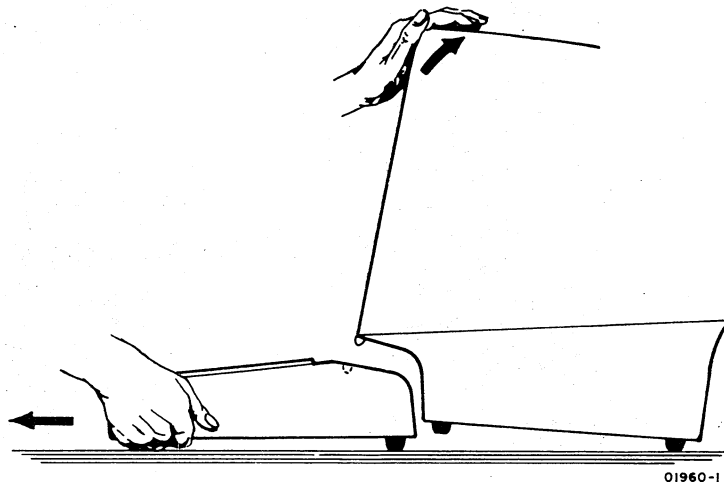

Figure 2-9. Removing the Detachable Keyboard

- 5) Move circuit breaker CBI at the left rear of the display terminal to its up position. This turns the power to the display terminal on.
- 6) Wait for the display to warm-up and for the cursor (blinking dash) to appear. If a cursor does not appear, adjust the INTENSITY control until it does.
- 7) Once the cursor appears on the screen, move the ON LINE/LOCAL switch to LOCAL and type in characters. Adjust the INTENSITY control until characters are easily visible, but not too bright.
- 8) The display terminal is now ready for use and power should be left on.

### **Specific Functions**

Set the following keyboard switches to the positions appropriate for the desired mode of terminal operation. Reference the descriptions of these switches given earlier in this section if necessary.

- ODD PAR/NO/EVEN PAR
- FULL DUP/HALF DUP
- HIGH RATE/300/LOW RATE
- 96/64
- PAGE

### **NONIMPACT PRINTER**

From the operation point of view, the nonimpact printer is a relatively simple device. It requires only a few initial checks, including checking of its paper supply before it is ready for operation. The following text gives the initial check items for the nonimpact printer and also provides instructions for loading paper into the printer.

#### **Check Items**

As with the other listings of check items, this one is normally run through just prior to bringing a terminal online for operation. Doing so helps assure that all of the devices function properly once the terminal is brought online. A check of the printer paper supply is included in the listing.

- 1) Check that all cabling at the rear of the printer cabinet is securely connected.
- 2) Check that the printer ac power cord is plugged into an appropriate power outlet.
- 3) Before applying power to printer, lift top cover to check paper supply and setting of line spacing switch. The switch should be back, for single spacing, or forward, for double spacing.
- 4) If paper supply is insufficient, refer to the following paper-loading instructions before proceeding with the next step. If the supply is sufficient, proceed to next step.
- 5) Close top cover of the printer and press the ON switch on top of printer.
- 6) Test the operation of the printer in the following manner:
  - a) At the terminal, place the keyboard/display in local mode by moving the ON LINE/LOCAL switch to LOCAL.
  - b) Type in a few lines of characters on the keyboard of the terminal.
  - c) Check the quality of the subsequent printout on the printer.
- 7) If the printout is of poor quality or the printer does not print at all, ask your supervisor to inspect the terminal.
- 8) If the printout is satisfactory, the printer is ready for operation.

### **Specific Functions**

Loading paper is the only specific function for the nonimpact printer. As with other initial device preparation functions, this task is only done as required. The following are instructions for loading paper into the nonimpact printer. Paper requirements are included at the end of this section.

- 1) If the printer is on, turn off by pressing the ON switch.
- 2) Lift the printer top cover.
- 3) Remove the remainder of the paper roll by lifting straight up and out of the printer.
- 4) Remove the spindle from the old roll and install the spindle in a new roll.

- 5) Unroll about 18 in (46 cm) from the paper roll.
- 6) Thread the paper beneath the paper rod and between the paper guides as shown in figure 2-10.

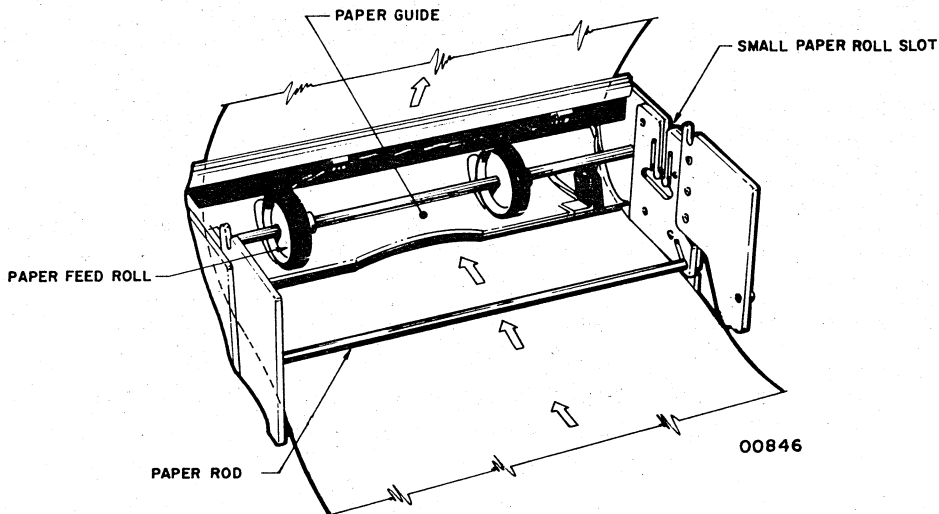

Figure 2-10. Loading Paper in Nonimpact Printer

- 7) Feed the paper through guides by turning the feed rolls with your hand until the paper slides through the slot in the cover.
- 8) Place the paper roll in paper roll slot and pull the free end of paper until there is no slack. Check that the paper is properly positioned under the wire paper guides on either side of paper.
- 9) Close the printer cover securely.
- 10) Press the ON switch. Printer is now ready for operation.
- 11) Press the LF switch to assure that the paper is feeding properly.

## IMPACT PRINTER

Included within the check items for the impact printer are checks of the printer forms (paper) supply and of print quality. If the forms supply is low, the operator should replenish the supply. If the overall print quality is poor, the operator should replace the printer ribbon and adjust the forms density control.

## Check Items

The following constitutes the initial preparation check items for impact printers.

- 1) Check that all cabling at the rear of the printer is securely connected.
- 2) Check that the printer ac power cord is plugged into an appropriate power outlet.
- 3) Press the ON side of the ON/OFF switch at the front of the printer. The backlight indicator of the switch comes on to indicate the power is connected.
- 4) Visually check the forms (paper) supply to assure there is a quantity sufficient for a reasonable period of printer operation (as based on past experience or anticipated use). If the supply appears insufficient, load the printer with a new supply of forms (refer to the following forms installation and alignment instructions) before proceeding with the next step. If the supply is sufficient, verify that the forms are loaded properly before proceeding.
- 5) Press the START/STOP switch on the top of the printer to place the printer online to the data source. The backlight indicator of the switch should come on. If the light does not come on, assure that the cover is securely closed. The printer has an interlock switch under its cover. Press the START/STOP switch again.
- 6) Once the START/STOP light comes on, test the operation of the printer in the following manner:
  - a) At the terminal, place the keyboard/display in local mode by moving the ON LINE/LOCAL switch to LOCAL.
  - b) Type in a few characters on the keyboard of the terminal.
  - c) Actuate the LINE FEED and CARRIAGE RETURN keys on the keyboard.
  - d) Check the quality of the subsequent printout on the printer.
- 7) If the printout is of an overall poor quality, replace the ribbon as described in the ribbon installation instructions that follow and/or adjust the forms density control of the printer.
- 8) If the printer does not print at all, recheck that the forms are loaded properly. If the printer still does not print, call your supervisor for assistance.
- 9) If clear, full characters are printed upon testing the printer, the printer is ready for operation.

## Specific Functions

The following paragraphs include instructions describing the operator functions for: 1) forms installation and alignment, 2) ribbon installation, and 3) format tape installation. Forms, ribbon, and format tape requirements are included at the end of this section.

### Forms Installation and Alignment

The following instructions are designed to aid the operator in correctly and easily installing and aligning the fanfold forms. This is easily performed if the operator stands in front of the printer after positioning the new forms to the rear of the printer.

- 1) Turn the printer off. Lift the front access panel slightly and slide it to the front of the printer, away from the forms throat area.
- 2) Place the fanfold forms behind the printer, directly below the forms input slot.
- 3) Insert the top form into the forms input slot under the tension bars. Continue feeding the forms until they are visible in the front of the printer.
- 4) Open the left tractor flap and position the forms on the tractor feed pins. Close the tractor flap.
- 5) Replace the front access panel and use the column guide for forms position reference.
- 6) Position the left tractor for the desired margin on the form.
- 7) Open the right tractor flap and position the right tractor so that the tractor feed pins can be seen through the form feed holes.
- 8) Position the form on the tractor feed pins and close the tractor flap. There should be no line skew from one tractor to the other.
- 9) Turn the printer on to actuate the FORM FEED switch. The format reader is now at the top-of-forms position.
- 10) Press the clutch retractor lever and use the forms positioning knobs to align the first line of print position on the forms to the print position.
- 11) Release the clutch retractor lever and the forms are ready for printing.

## Ribbon Installation

These instructions are designed to aid the operator in correctly preparing and loading the ribbon.

To unload the spool, perform the following steps.

- 1) Remove the ribbon from the printer.
- 2) Place the spool with the most ribbon on the right ribbon mandril.
- 3) Place the other spool on the stationary mandril located just behind the right ribbon mandril.
- 4) Turn the printer on.
- 5) When the ribbon stops, remove both spools and tear the ribbon leader off the empty spool.

To load the spool, perform the following steps.

- 1) With the ribbon routed off the bottom of the full spool and over the top of the empty spool, as shown in figure 2-11, wrap the ribbon leader over one of the arrow-shaped holding clamps of the empty spool.
- 2) Pull the ribbon back against the point of the arrow-shaped clamp until the clamp penetrates the ribbon.
- 3) Wind several (5 to 6) turns of ribbon on the empty spool.
- 4) The ribbon is now ready to be loaded.

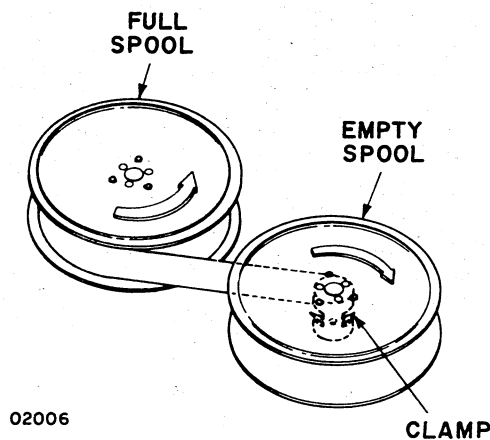

Figure 2-11. Spool Loading

To load the ribbon, perform the following steps (refer to figure 2-12).

- 1) Place the full spool on the left ribbon mandril.
- 2) Route the ribbon around the two guide rollers, passing it through the slot in the ribbon sense arm.
- 3) Route the ribbon between the ribbon guide and the printhead and around the front guide roller on the printhead.
- 4) Route the ribbon behind the rear guide roller on the printhead and then all the way to the right behind the far guide roller.
- 5) Route the ribbon in front of the next guide, through the slot in the ribbon sense arm, and behind the last guide roller.
- 6) Install the ribbon spool on the right ribbon mandril.
- 7) Slide the printhead all the way to the right and allow it to spring back. This should route the ribbon beneath the tip of the clamp on the printhead.
- 8) The ribbon is now ready for operation.

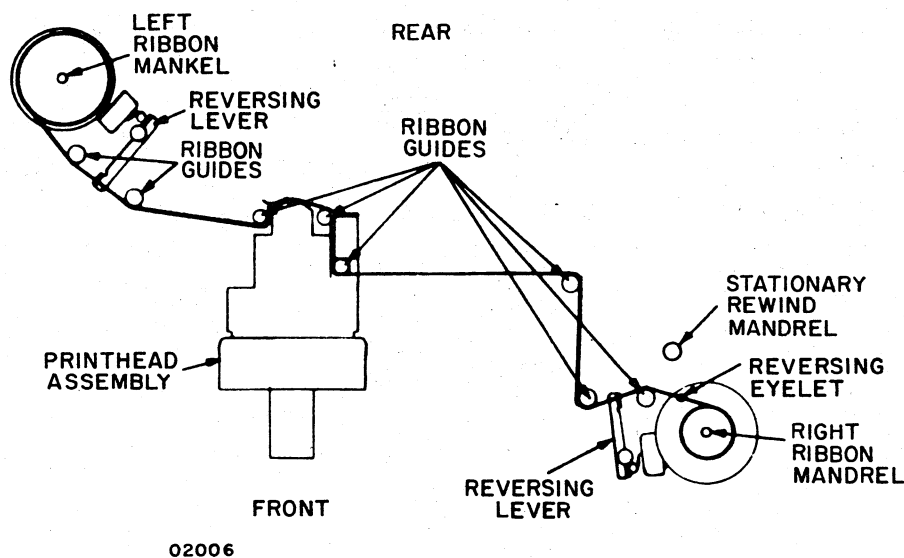

Figure 2-12. Ribbon Loading

## Format Tape Installation

To install the format tape, perform the following steps.

- 1) Remove the format reader housing.
- 2) Lift the brush block tension lever.
- 3) Thread the format tape between the brush block and the drive sprocket. Channel 1 should be to the inside.
- 4) Route the format tape, using path A or path B as shown in figure 2-13, depending on the tape length. Path A should be used for the short tapes. If the tension arm cannot take up all the slack or if the tension arm contacts the cabinet, path B should be used.
- 5) Press the brush block tension lever.
- 6) Reinstall the format reader housing.
- 7) The format tape is ready for operation.

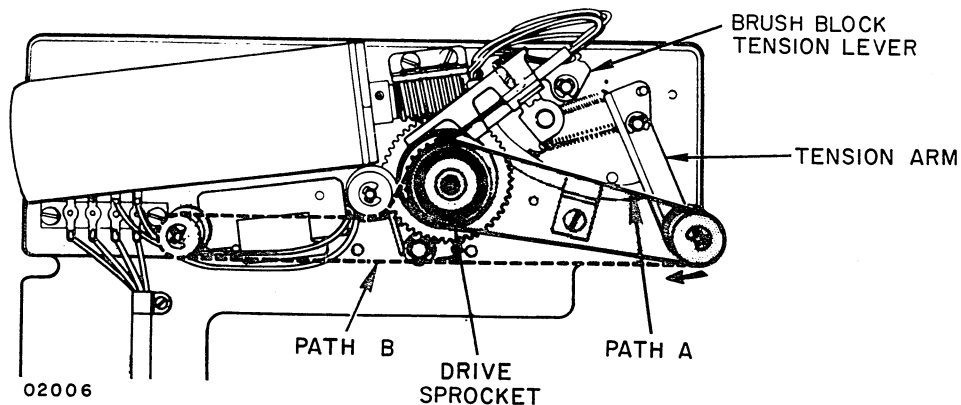

Figure 2-13. Format Tape Installation

## OPERATOR SUPPLIES

The following paragraphs list the recommended supplies for the nonimpact printer and the impact printer.

### Nonimpact Printer

Nonimpact printers use continuous-roll thermal paper for printing messages. White with blue print paper is available in 100 ft (30.5 m) rolls. Paper may be ordered in cartons of 24 rolls (CDC part number 51772001). To order paper, contact the nearest Control Data Business Products representative.

## Impact Printer

Impact printers use fanfolded forms that have sprocket drive holes along each side. For best print quality and printer operation, the forms and ribbons used in impact printers should meet the following general requirements.

### Forms Recommendations

The printer will handle standard continuous forms paper with feed holes on each edge, with or without marginal perforations.

The forms may be from 4.0 to 16.74 in (10.16 to 42.55 cm) in width including margins, and 3.5 to 18.0 in (8.89 to 45.72 cm) long from fold to fold. When using the output paper basket, the forms length is limited to 11.0 in (27.94 cm) from fold to fold.

The forms must have sprocket holes punched along both margins  $25 \pm 0.03$  in ( $63.5 \pm 0.076$  cm) from the paper edge to the hole center lines. The distance between hole center lines must be  $0.500 \pm 0.005$  in ( $1.27 \pm 0.013$  cm) nonaccumulative, and the diameter of the holes should be  $0.156 \pm 0.010$  in ( $0.396 \pm 0.025$  cm). Multiple part forms must be suitably fastened with nonmetallic fasteners. The requirements for multiple part forms are listed in table 2-1.

TABLE 2-1. IMPACT PRINTER FORMS REQUIREMENTS

PARTS	WHITE SULPHITE BOND PAPER	CARBON PAPER
1	15 lb continuous bond (56 g/m <sup>2</sup> )	—
1	24 lb continuous bond (90 g/m <sup>2</sup> )	—
2 and 3	12 lb continuous bond (45 g/m <sup>2</sup> )	8 lb (14 g/m <sup>2</sup> )
2 and 3	15 lb continuous bond (56 g/m <sup>2</sup> )	8 lb (19 g/m <sup>2</sup> )
4 and 5	12 lb continuous bond (45 g/m <sup>2</sup> )	6 lb (14 g/m <sup>2</sup> )

### Ribbon Recommendations

The ribbon used is 0.5 in (1.3 cm) wide by 66 ft (20 m) long and runs on an angle across the printing area in order to print on the full width of the ribbon. The ribbon must have an eyelet located at least 6 in (15.2 cm) from each end for ribbon reversal. Recommended ribbon materials and thickness should be used. The ribbon is wound on a single spool when purchased and must be attached to any empty spool before insertion on the ribbon mandrils. Order CDC part number 95371700 for ribbon and spools, and 76616500 for an empty ribbon spool.

## Format Tape

The format tape is a standard 1 in (2.54 cm) wide tape with sprocket holes on 0.1 in (0.254 cm) centers. The standard format tape (CDC part number 76621000) comes with channel 3 (line feed) already punched. Channel 1 should be punched to correspond to the top of forms positions. Channel 2 may be punched at any vertical tab desired. The format tape may be any length from 5.5 to 12.5 in (13.97 to 31.75 cm).

## TERMINAL OPERATION

This portion describes terminal operation. There are two principal modes of terminal operation: online operation, and offline or local operation. Before proceeding with the descriptions of these two modes of operation, this portion provides some general operating information.

### GENERAL OPERATING INFORMATION

Following is a brief functional description of some of the controls on the terminal keyboard. The descriptions are included here to provide the terminal operator with a quick reference for the functions of these controls.

#### ODD PAR/NO/EVEN PAR Switch

This switch determines whether or not the terminal checks received character codes for parity, and if so, whether it checks for odd parity or even parity. With the switch in the NO position, the terminal does not check parity of received codes. In either the ODD PAR or EVEN PAR positions of the switch, the terminal checks for parity errors in received codes. If one is detected, a parity error symbol (■) appears on the display screen. This symbol will also appear on the screen if the central processor breaks off a transmission to the terminal for some reason. When a parity error symbol appears on the display screen, reinstate transmission of the message. If these symbols consistently appear on the screen and cannot be eliminated by repositioning the ODD PAR/NO/EVEN PAR switch, call your supervisor or terminal maintenance personnel.

#### ON LINE/LOCAL Switch

When in the ON LINE position, this switch enables information keyed-in on the terminal keyboard to be transmitted to the system central processor and enables the terminal to receive information from the system central processor. When in the

LOCAL position, this switch disables the transmission of information keyed-in on the terminal keyboard to the system central processor and directs keyed-in data to the display screen and printer. Whether the terminal can or cannot receive information from the system central processor while in LOCAL mode, depends upon the state of the terminal's internal CONSTANT DTR switch.

### **FULL DUP/HALF DUP Switch**

The positioning of this switch determines whether online transmissions from the terminal are directed only to the transmission lines (FULL DUP position) or to the transmission lines, the display screen, and the printer (HALF DUP). The FULL DUP position is intended for use on communication facilities that echoes received data back to the transmitting terminal. The terminal then displays and prints the received data to provide verification of proper message transmission. The HALF DUP position of the switch is intended for communication facilities not having an echo back capability. If this switch is positioned incorrectly during online operation, it is easy to detect; either keyed-in data will not display and print (FULL DUP selected when HALF DUP should be) or will display and print double (HALF DUP selected when FULL DUP should be).

### **HIGH RATE/300/LOW RATE Switch**

This switch determines how fast the terminal transmits keyed-in data to the system central processor. The 300 position of the switch is fixed, while the actual rates of the HIGH RATE and LOW RATE positions are determined by internal switch settings. Communication facilities will not properly handle transmission rates other than what they are specified for. Assure that this switch is set to match the capabilities of the communication system.

### **94/64 Switch**

The setting of this switch determines which ASCII subset (96/64) the terminal transmits. When the switch is up, the full 96-character subset is available for transmission. When this switch is down, only the 64-character subset, which excludes lowercase alpha characters and ~, }, {, ` and | symbols, is available for transmission. The setting of this switch does not affect received codes. The system central processor may transmit lowercase codes, which will display even with the 96/64 switch in the 64 position.

## **PAGE Switch**

This switch selects between page and scroll mode operation of the display. In page mode (switch down), the entire display screen is available for the entry and display of data. In scroll mode (switch up), the normal data entry and display area is line 24 of the screen. Each time line 24 fills up or a line feed occurs, the data in line 24 and all preceding lines moves up one line, the cursor resets to the left margin of line 24, and any data in line 1 scrolls off the screen and is lost.

## **ONLINE OPERATION**

Online operations are those which occur between the terminal and the system central processor. The following text describes general online operations relative to the keyboard display terminal. Topics described are: 1) establishing communications, 2) logging into the system, 3) sending messages, 4) receiving messages, and 5) logging out of the system.

### **Establishing Communications**

This procedure is normally necessary only in terminal installations using a modem with a handset (telephone) attached. The handset is included, because the communication facility between the terminal and the system processor is of a switched type. The terminal operator must dial up and connect to the terminal before it can communicate with the system processor. The procedure for establishing communications with this system is as follows:

- 1) Clear the display by pressing the CLEAR key on the keyboard.
- 2) Set the ON LINE/LOCAL switch on the keyboard to ON LINE.
- 3) Set all other keyboard control switches to their proper operating positions. Reference operating procedures for specific terminal installation.
- 4) Lift the handset receiver from its cradle and press the TALK pushbutton on the handset.
- 5) Dial the number assigned for connecting the system central processor. Refer to operating procedures for specific terminal installation.
- 6) The data set at the other end of the line will either return a busy signal or begin to ring. If a busy signal is received, the line is already in use. Replace the receiver in the handset cradle and wait a short time before redialing. If a ring signal is heard, wait until the phone is answered and a high-pitched tone is returned.
- 7) Press the DATA button on the handset and place the receiver back in its cradle. The terminal is now connected to the system central processor and log-in procedures may be carried out.

If the terminal modem does not include a handset, the terminal uses a dedicated communication facility. Establishment of the communication link between the terminal and the central processor is not required. If acoustic couplers or handsets other than the type described are used, refer to the operating instructions supplied by the manufacturer of the coupler or handset.

### **Logging In to the System**

Logging in to the system involves keying in a message to the system central processor to inform the processor that your terminal is now online and ready to accept communications. Log-in procedures vary from system to system; refer to operating procedures for a specific terminal installation. Additionally, not all systems require logging in.

### **Sending Messages**

In online mode of operation, the terminal transmits each character to the system central processor as it is keyed in. Sending a message simply requires typing in the desired message on the terminal keyboard. Display and printing of a transmitted message depends on the operating mode selected (full-duplex or half-duplex) and on the type of communication facility connecting the terminal to the system central processor. Keyed-in messages are always displayed and printed when operating in the half-duplex mode of online transmission. If keyed-in characters display and print in duplicate, the mode switch is positioned incorrectly; that is, the FULL DUP/HALF DUP switch is in HALF DUP when it should be in FULL DUP. If keyed-in characters neither display nor print when desired, the mode switch may again be positioned incorrectly; that is, it may be in FULL DUP when it should be in HALF DUP.

In the online mode of terminal operation, all keyboard keys, including control-code and cursor positioning keys are active, and all keyed-in characters result in the transmission of associated codes to the system central processor (refer to section 4 for complete code set listing). If an error is made while keying in a message, refer to the operating procedures for the particular terminal installation since the systems will use different methods of correcting erroneous message transmissions.

### **Receiving Messages**

While operating in online mode, the terminal can receive messages or control outputs from the system central processor at any time. Outputs from the system central processor fall into two categories: solicited and unsolicited.

Solicited outputs include all anticipated outputs, such as those requested or expected as the result of a keyboard input. Unsolicited outputs are not directly the result of a keyboard input, and therefore, the terminal operator cannot anticipate them. Although most systems contain safeguards to prevent received outputs from interfering with transmit-data displays or printouts, the terminal operator should remain alert to this existing situation. If a terminal is internally conditioned to accept X/Y positioning output from the central processor and is operating in page mode, unsolicited outputs from the processor may reposition the cursor and overwrite data already appearing on the display screen. In scroll mode, X/Y positioning commands are not accepted and unsolicited outputs will be displayed in line 24 of the display screen. As noted earlier, the terminal operator must remain alert to the possibility of receiving unsolicited outputs from the system central processor while he is in the processor of keying in an input message.

In online, half-duplex mode operation of the terminal, both received and transmitted data messages are displayed and printed; while in online, full-duplex mode, only received data messages are displayed and printed. In either mode, the printer simply follows display activity within its control code capabilities. The nonimpact printer responds to backspace, line feed, and carriage return control codes; and the impact printer responds to carriage return, line feed, vertical tabulation, and form feed control codes. All other control codes simply cause the printer to space. To track display activity, a printer must be ready and on: the nonimpact printer has paper loaded and power on; and the impact printer has paper loaded, power on, and is started (START/STOP switch-indicator light on).

### **Logging Out of the System**

Some systems will require log-out messages to inform the system central processor that a terminal is through using the system. If a log-out message is required, it is important to log out as soon as the terminal is through using the system, because the cost of using the system is often related to the amount of time the system remains connected to the terminal.

### **OFFLINE OR LOCAL OPERATION**

Offline or local operation of the terminal is entered by moving the ON LINE/LOCAL switch on the terminal keyboard to the LOCAL position. Moving this switch to LOCAL disconnects the transmit interface of the terminal from the communication facility and blocks the transmission of keyed-in data to the system central processor. Keyed-in information displays and prints while in local mode regardless of the positioning of the FULL DUP/HALF DUP switch.

Whether or not outputs directed to the terminal by the system processor are entered in local mode depends on switch conditioning within the terminal. If the CONSTANT DTR switch within the terminal is set to enable a constant data-terminal ready signal to the modem, the terminal will accept receive information even when switched to local mode. If the CONSTANT DTR switch is set to its switched position, the data-terminal ready signal to the system central processor drops when the terminal is switched to local-mode operation and the terminal ignores any received data.

---

This section contains information regarding the transmit/receive characteristics of the terminal. The characteristics discussed are as follows:

- Transmit/receive baud rates
- Half- and full-duplex modes of operation
- Transmit/receive word sizes and formats
- Transmit/receive code set (including receive-code restrictions)
- Error detection
- Current loop communication interface

## TRANSMIT/RECEIVE BAUD RATES

The terminal can transmit and receive bit-serial, word-serial information at any of the following baud rates: 110, 150, 200, 300, 600, 1200, 1800, 2400, 4800, and 9600 baud. Selection of baud rate is accomplished by way of internal switches and a HIGH RATE/300/LOW RATE switch on the keyboard. The 300 position of the HIGH RATE/300/LOW RATE switch is fixed to select a transmit/receive rate of 300 baud. The HIGH RATE and LOW RATE positions of the keyboard switch are used to select any two of the preceding baud rates.

The setting of the internal baud rate select switches determines which particular baud rate is available at each position of the keyboard switch. The HIGH RATE and LOW RATE designations of the keyboard switch are not restrictive as their names imply, as either position of the switch can be set to correspond with any of the previously mentioned baud rates. For example, the internal baud rate select switches may be set to give a 110-baud transmit/receive rate at both the HIGH RATE and LOW RATE positions of the keyboard switch. Setting of the internal baud rate select switches is described in section 2 of this manual.

Although the keyboard display terminal can accept data at any of the baud rates, the receive rates of the two printer peripherals available with the terminal are considerably more restrictive. The nonimpact printer accepts data at a maximum

rate of about 300 baud, while the impact printer accepts data at rates up to 1200 baud. Additionally, the impact printer has internal switches and jumpers for selecting baud rates (150, 300, 600, or 1200 baud), odd- or even-parity checking of received words, and data-word size (5, 6, 7, or 8 bits). Baud rate selection for the terminal and its printer peripheral must match and must not exceed the capabilities of the communication facility.\*

## **HALF- AND FULL-DUPLEX MODES OF OPERATION**

Within the context of the terminal itself, the terms half- and full-duplex refer to the handling of data internally and not to the mode of data transmission on the communication channel, which may be either a half- or full-duplex, two- or four-wire facility. When half-duplex mode of terminal operation is selected via the keyboard FULL DUP/HALF DUP switch, keyed-in information is routed to the display, the printer, and the transmit interface. This mode of transmission is for use on communication facilities that do not turn a received character around and send it back to the originating terminal, such as nonecho checking channels.

The full-duplex mode of terminal operation enables keyed-in information to the transmit interface and does not directly route it to the display or printer. The only information displayed or printed in the full-duplex mode is received information, and this mode is useful for terminals connected to echo check communication facilities.

Incorrect positioning of the keyboard switch is relatively easy to detect, if display and printing of transmitted information is desired. For example, if the terminal is connected to an echo check communication channel and the FULL DUP/HALF DUP switch is in the HALF DUP position, keyed-in data will appear in duplicate on the display screen; once as it is transmitted and once as it is echoed back from the receiving station. If the switch is in the FULL DUP position and the communication channel is a nonechoing type, pressing a data key on the keyboard results in no display or printing whatsoever. Correction of either condition is accomplished by reversing the position of the FULL DUP/HALF DUP switch.

## **TRANSMIT/RECEIVE WORD SIZES AND FORMATS**

A typical transmit sequence for a data word on a voltage level communication facility (one using modems) is shown in figure 3-1. Word transmission on a 20-milliampere current loop channel is similar, except that a marking condition is indicated by current flow and a spacing condition is indicated by no current flow. Additionally, the RS-232-C/CCITT V.24 control circuit signals are not necessary in current loop operation.

---

\* See appendix B of this manual for impact printer print rate information.



Notice that two stop bits, in figure 3-1, are shown in the transmitted data word. These two stop bits are transmitted only during 110-baud operation of the terminal; operation of the terminal at any other baud rate transmits only one stop bit. Receive words may include either one or two stop bits at any of the available transmit/receive baud rates; otherwise, the format of received words is identical to that of transmitted words.

In all cases, bit timing is determined by the selected transmission baud rate. The baud rate of the terminal must be set the same as the systems baud rate. Also, note that the peripheral printers impose baud rate limitations on the terminal: nonimpact printer, 300 baud maximum; and impact printer, up to 1200 baud. The impact printer has internal switches for selecting baud rates of either 150, 300, 600, or 1200 baud; odd or even word-parity checking; and data-word size (5, 6, 7, or 8 bits). The nonimpact printer accepts only even-parity words. A typical terminal subsystem with a printer attached would use words consisting of a start bit, 7 data bits, a parity bit, and a stop bit.

No special considerations for data word timing are necessary with the exception of the clear (CAN) code. A minimum of 40 ms must follow the receipt of the CAN code (030<sub>g</sub>) from the central processor. The delay may consist of either an idle line (marking) or a specific number of idle codes (DEL or NUL for example).

## TRANSMIT/RECEIVE CODE SET

The following paragraphs provide quick reference to the display terminal code set. The next section of this manual contains complete character and symbol code listings for the terminal and for the peripheral printers. The transmit/receive code set of the keyboard display terminal is shown in figure 3-2. Notice that the figure uses the traditional communications method of identifying the seven bit positions of a transmit/receive word with b1 through b7, rather than with b0 through b6 as is common in the data-processing field.

The code set shown in figure 3-2 is a standard ASCII 128-code set, consisting of 33 control codes (columns 0 and 1 and row 15 of column 7) and 95 alphanumeric character codes. The heavily outlined portion of the figure represents the 64-character ASCII subset of alphanumerics accessible through the keyboard when the 96/64 switch is in position 64 (down). Regardless of the positioning of the 96/64 switch, the set of alphanumerics available for display or printing upon receipt of the appropriate codes from the system central processor remains constant at 95; that is, the 64 position of the 96/64 switch only restricts keyboard access to the lowercase alphanumeric codes.

BITS					COLUMNS										
b7	b6	b5	b4	b3	b2	b1	0	0	0	0	1	1	1	1	
					0	1	2	3	4	5	6	7			
					0	1	2	3	4	5	6	7			
0	0	0	0	0	0	NUL	DLE	SP	0	@	P	,	p		
0	0	0	1	1	1	SOH	DC1	!	1	A	Q	a	q		
0	0	1	0	0	2	STX	DC2	"	2	B	R	b	r		
0	0	1	1	0	3	ETX	DC3	#	3	C	S	c	s		
0	1	0	0	0	4	EOT	DC4	\$	4	D	T	d	t		
0	1	0	1	0	5	ENQ	NAK	%	5	E	U	e	u		
0	1	1	0	0	6	ACK	SYN	&	6	F	V	f	v		
0	1	1	1	0	7	BEL	ETB	/	7	G	W	g	w		
1	0	0	0	0	8	BS	CAN	(	8	H	X	h	x		
1	0	0	1	0	9	HT	EM	)	9	I	Y	i	y		
1	0	1	0	0	10	LF	SUB	*	:	J	Z	j	z		
1	0	1	1	0	11	VT	ESC	+	;	K	[	k	{		
1	1	0	0	0	12	FF	FS	,	<	L	\	l	;		
1	1	0	1	0	13	CR	GS	-	=	M	]	m	}		
1	1	1	0	0	14	SO	RS	.	>	N	^	n	~		
1	1	1	1	0	15	SI	US	/	?	O	_	o	DEL		

01142

Figure 3-2. Terminal Code Set

All codes shown in figure 3-2 may be generated and transmitted by the terminal. The codes may be received by the terminal; however, the terminal only actively responds to the 13 control codes as shown in table 3-1.

Control characters, other than those listed, act only as idle characters when sent to the terminal unless the INTERNAL TEST switch is in the enable position. In this case, a symbol is displayed for each control code received; control codes, including those previously listed, do not perform any function other than displaying their associated symbol. See section 2 for a description of the INTERNAL TEST switch and section 4 for a listing of all displayable symbols.

TABLE 3-1. TERMINAL CONTROL CODES

ASCII MNEMONIC	OCTAL CODE	FUNCTION
BEL	007	Sound audible alarm for 250 ms
BS	010	Backspace cursor without affecting display data
LF	012	Move cursor down a line from present position without affecting displayed data (page mode) or scroll screen data in scroll mode
CR	015	Move cursor to beginning of current line or next line, depending on setting of internal AUTO LINE FEED switch
NAK	025	Move cursor ahead a character position without affecting displayed data
SYN	026	Clear line containing cursor from position of cursor to end of line; cursor does not move
CAN	030	Clear display memory and reset cursor to home position
EM	031	Reset cursor to home position without affecting displayed data
SUB	032	Move cursor up a line from present position without affecting displayed data
ESC	033	Idle character or X-Y positioning characters follow, depending upon position of internal X-Y positioning switch
SO	016	Advance cursor one position and initiate a low intensity field
SI	017	Terminate a highlight field (low intensity or blink) and advance cursor one position
ETB	027	Advance cursor one position and initiate blink field

## **ERROR DETECTION**

The terminal has the capability of detecting parity or format errors in received data words. To perform parity checking, the ODD PAR/NO/EVEN PAR switch on the keyboard must be set to either its ODD PAR or EVEN PAR position. When the switch is set to one of these positions, the terminal checks to assure that received codes have the appropriate odd or even parity; if not, a parity error symbol (■) displays in lieu of the received character. The terminal operator must note the error condition and must initiate either retransmission or any other error correction capabilities of the system central processor. When the ODD PAR/NO/EVEN PAR switch is set to its NO position, the terminal does not check received words for correct parity.

Format errors occur when the terminal detects a received word without a valid stop bit (marking condition) in bit position 10 (counting from start bit = bit 1). Detection of a format error causes the terminal to react in much the same manner as when it receives a Break signal from the system central processor; that is, a parity error symbol (■) appears on the display screen in lieu of character containing the format error and the terminal alarm sounds for about 200 ms. Again, the terminal operator must initiate retransmission or call for any other error correction facilities implemented by the system central processor.

## **CURRENT LOOP COMMUNICATION INTERFACE**

Figures 3-3 and 3-4, respectively, show interface connections for examples of two different current loop communication facilities on which the terminal may be used.

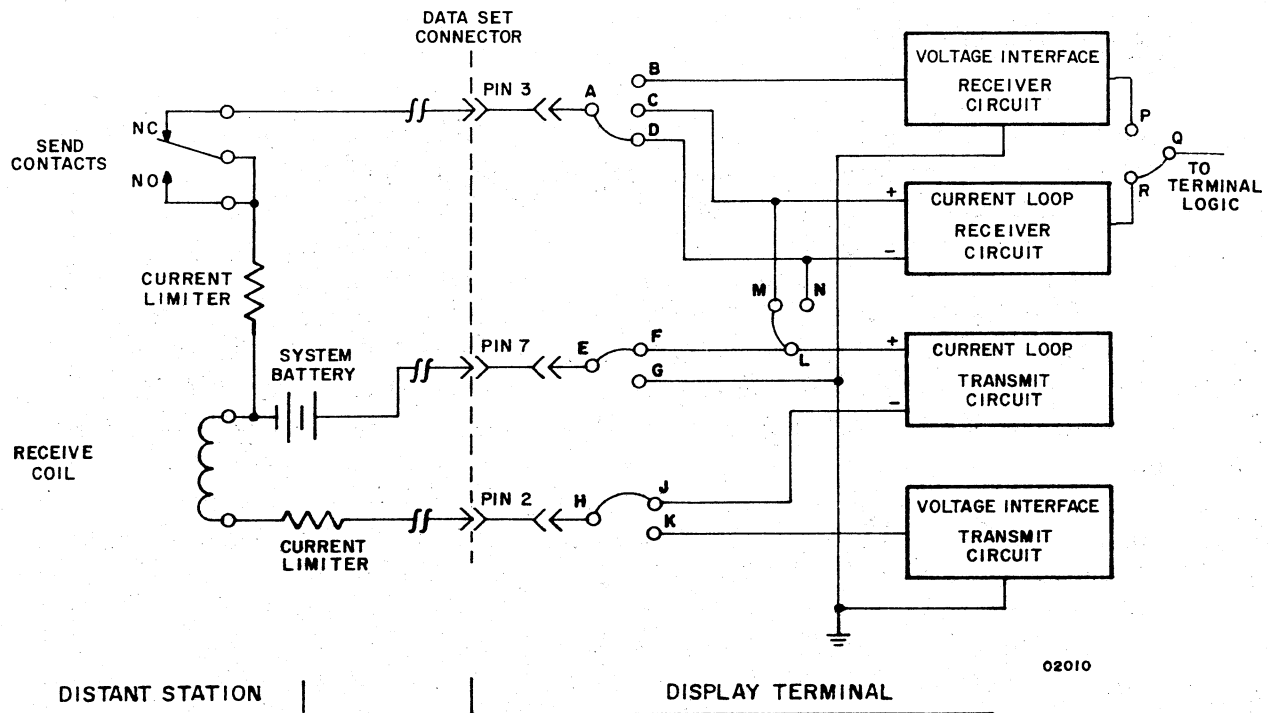

Figure 3-3. Data Set Connector Pin Assignments for Unipolar, Full-Duplex, Current Loop Communication Channel\*

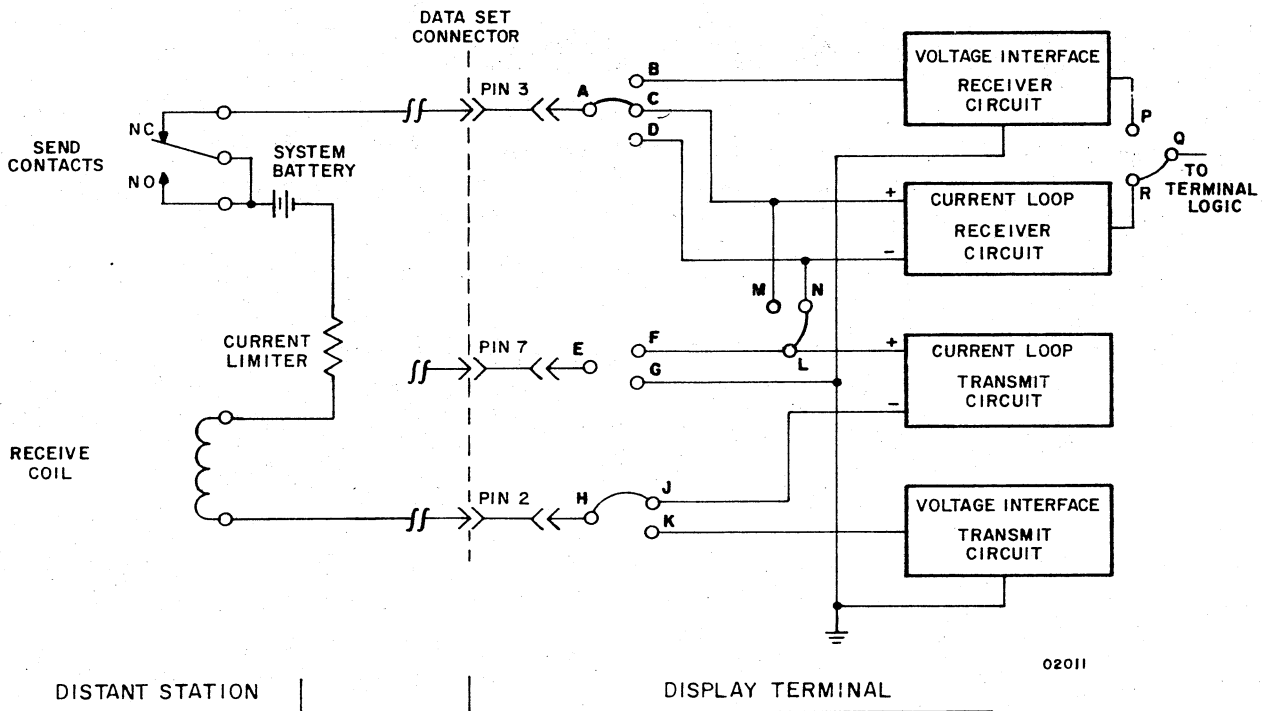

Figure 3-4. Data Set Connector Pin Assignments for Unipolar, Half-Duplex, Current Loop Communication Channel\*

\* CURRENT LOOP CIRCUITS ARE ONLY AVAILABLE IN TERMINALS WITH THAT FEATURE INSTALLED. SYSTEM BATTERY IS 24 V DC AND CURRENT LIMITERS ARE SELECTED FOR 20-MILLIAMPERE FLOW.

This section contains character and symbol code listings and dot-matrix symbol formations for the keyboard display terminal and the two peripheral printer devices available for use with the terminal.

The alphanumeric characters and symbols available on the terminal keyboard are shown in table 4-1, while figure 4-1 shows the dot-matrix formations and octal codes for these characters and symbols. Figure 4-2 shows the dot-matrix formations and lists the octal codes for the control code repertoire of the keyboard display terminal. Display of the control code symbols is only possible when the INTERNAL TEST switch of the terminal is in its enable position (refer to Internal Controls heading in section 2).

TABLE 4-1. DISPLAY KEYBOARD ALPHANUMERIC CHARACTER SET

UPPERCASE SYMBOLS	A B C D E F G H I J K L M N O P Q R S T U V W X Y Z		
LOWERCASE SYMBOLS	A B C D E F G H I J K L M N O P Q R S T U V W X Y Z		
NUMERALS	0 1 2 3 4 5 6 7 8 9		
CHARACTER	NAME	CHARACTER	NAME
	Space (Nonprinting)	;	Semicolon
!	Exclamation Point	<	Less Than
"	Quotation Marks (Diaeresis)	=	Equals
#	Number Sign	>	Greater Than
\$	Dollar Sign	?	Question Mark
%	Percent	@	Commercial At
&	Ampersand	[	Opening Bracket
'	Apostrophe (Acute Accent)	\	Reverse Slant
(	Opening Parenthesis	]	Closing Bracket
)	Closing Parenthesis	^	Caret
*	Asterisk	_	Underline
+	Plus	`	Grave Accent
,	Comma (Cedilla)	{	Opening Brace
-	Hyphen (Minus)		Vertical Line
.	Period (Decimal Point)	}	Closing Brace
/	Slant	~	Equivalent (Overline)
:	Colon		Vertical Line for Parity Error

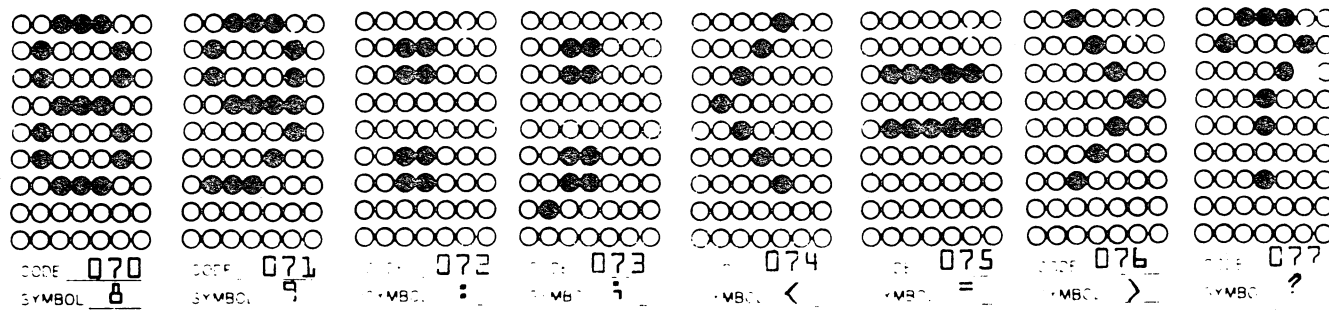
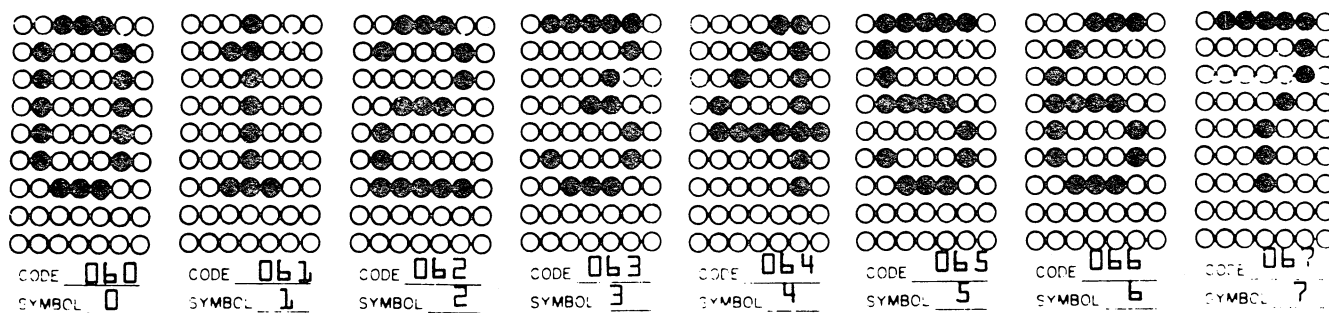
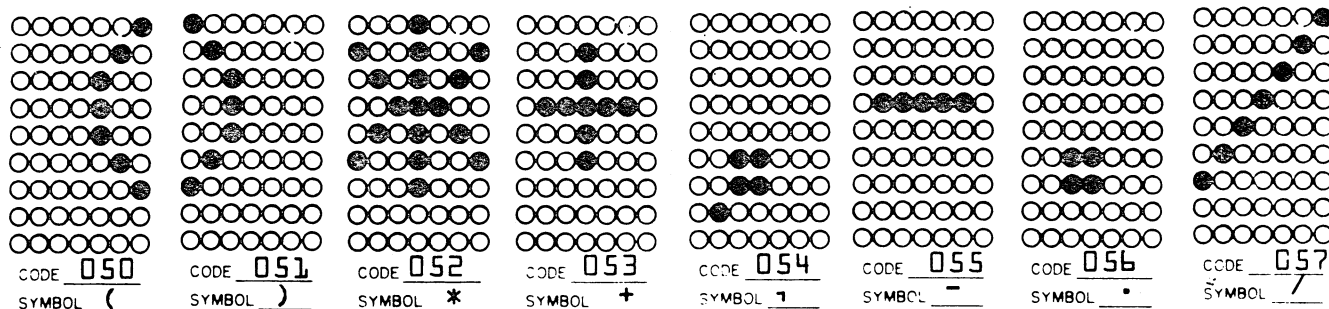
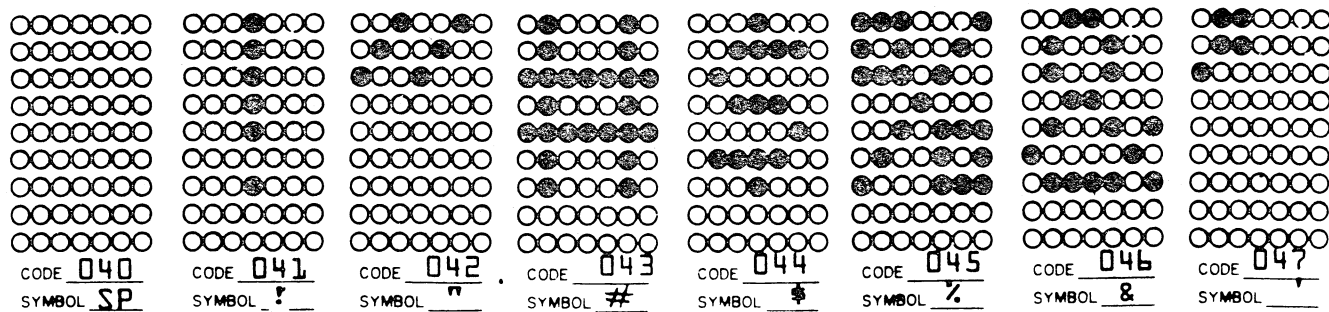

02001

Figure 4-1. Alphanumeric Dot-Matrix Formations and Octal Codes (Sheet 1 of 3)

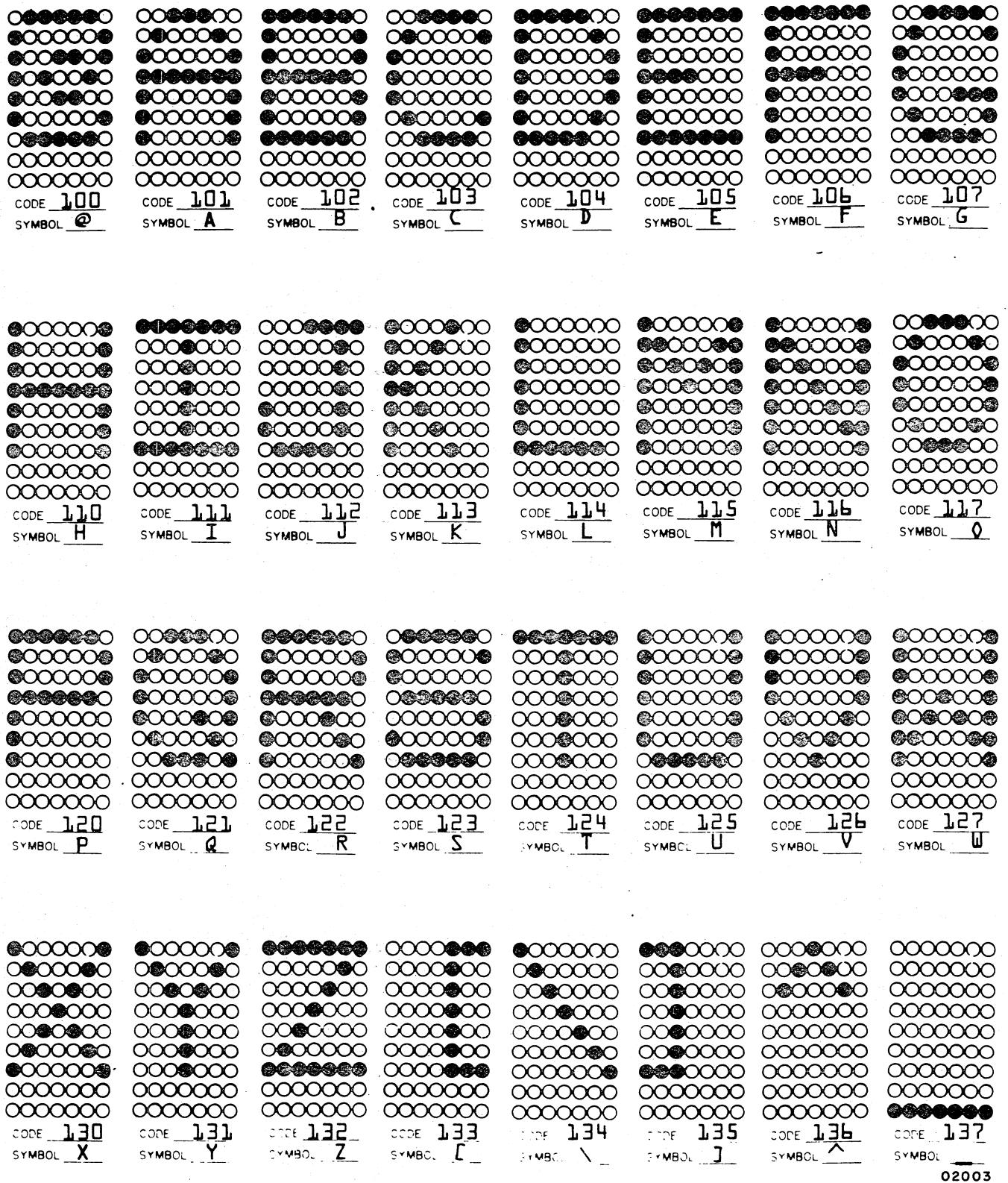

02003

Figure 4-1. Alphanumeric Dot-Matrix Formations and Octal Codes (Sheet 2 of 3)

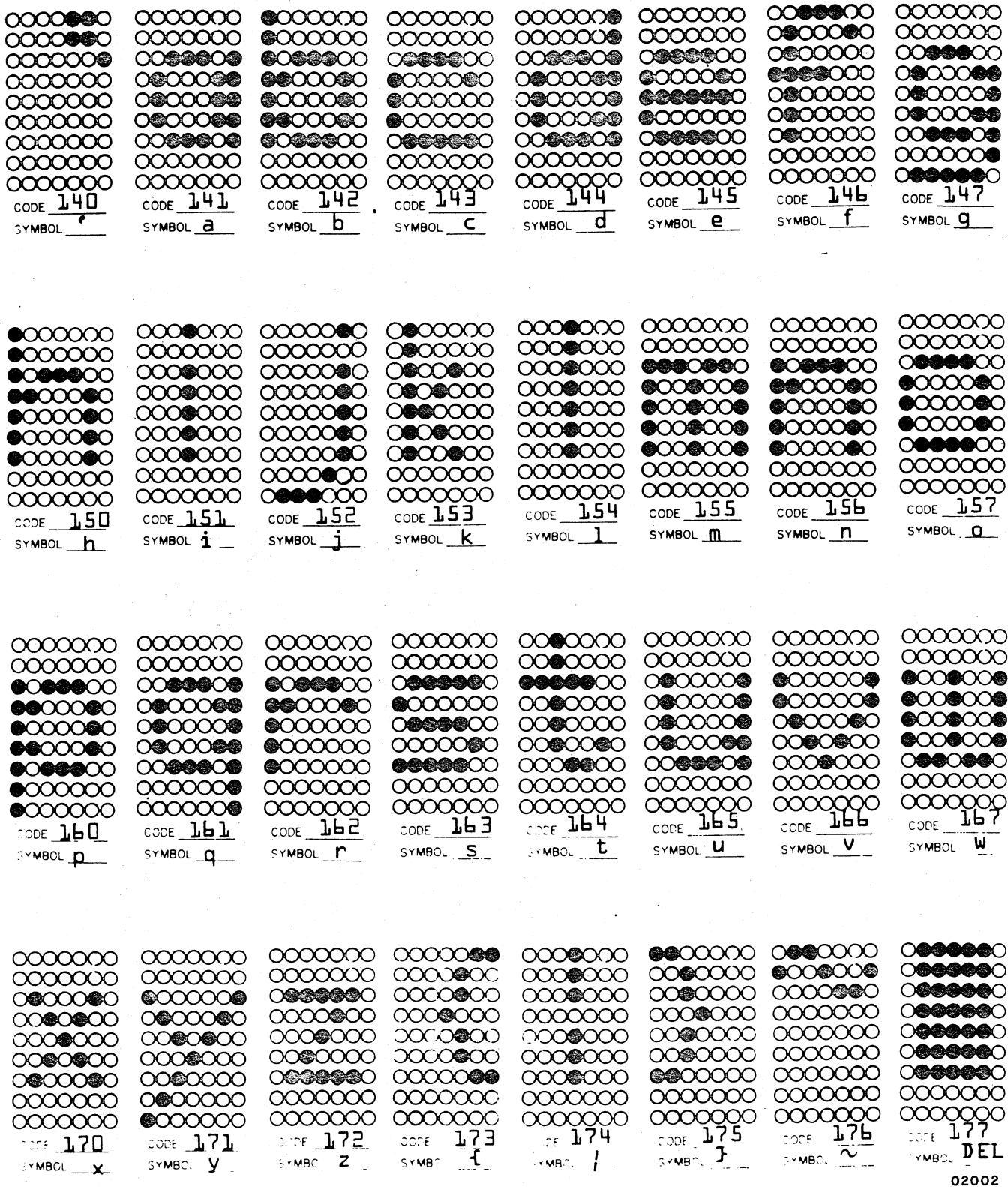

02002

Figure 4-1. Alphanumeric Dot-Matrix Formations and Octal Codes (Sheet 3 of 3)

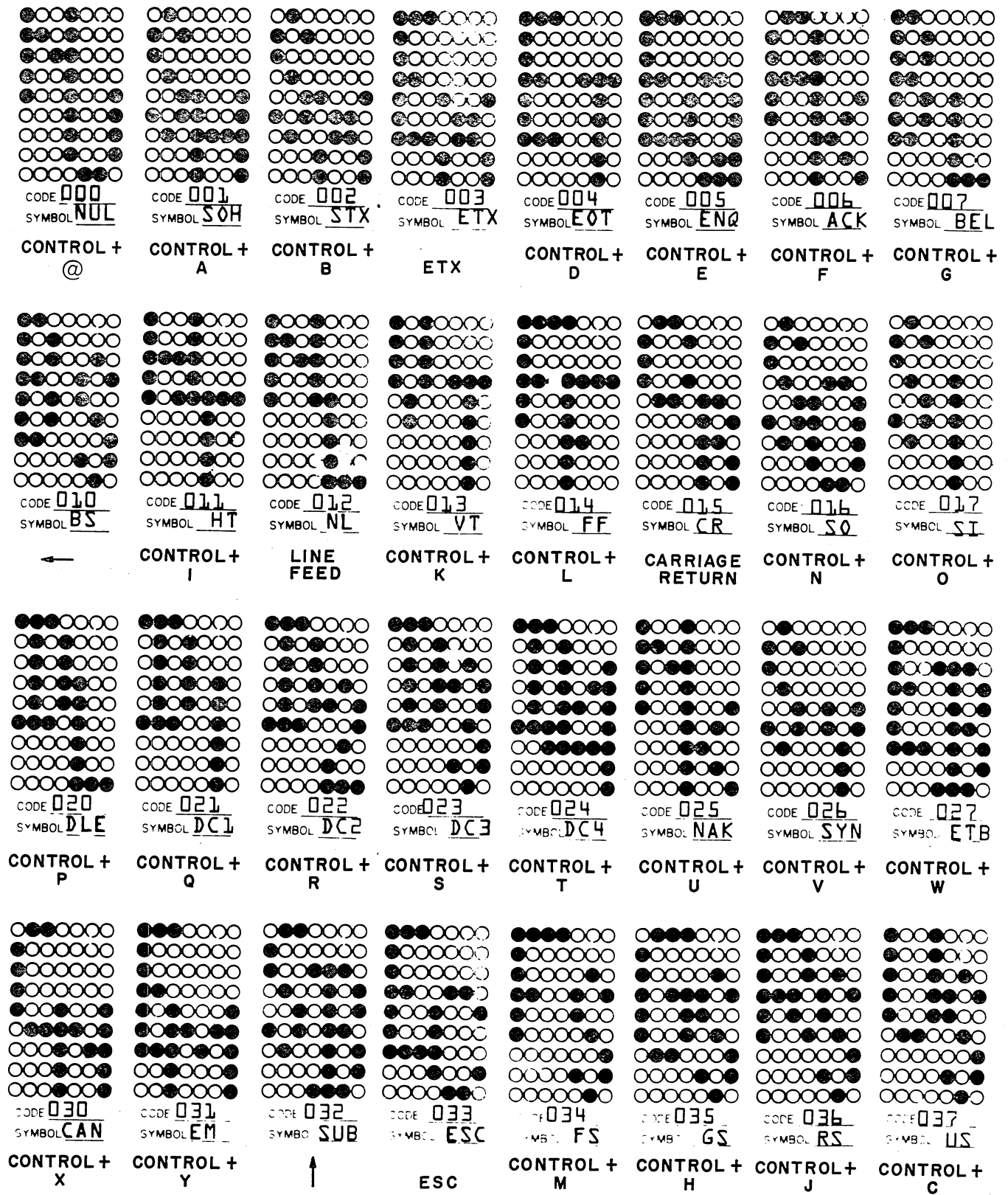

Figure 4-2. Control Code Dot-Matrix Formations and Octal Codes\*

\* ASCII delete code (DEL) is listed with preceding alphanumeric codes (see 177g).

The alphanumeric characters and symbols available for printing on the nonimpact printer are shown in table 4-2. With a few minor differences, these characters and symbols are much the same as those available on the keyboard display. Figure 4-3 shows the dot-matrix formations for the nonimpact printer character set; it also lists the octal codes for each character and for the three control codes to which the nonimpact printer responds.

Figure 4-4 contains the dot-matrix formations for the impact printer character set; it also lists octal codes for the character set and for the four control codes to which the impact printer responds.

TABLE 4-2. NONIMPACT PRINTER ALPHANUMERIC CHARACTER SET

UPPERCASE SYMBOLS	A B C D E F G H I J K L M N O P Q R S T U V W X Y Z		
LOWERCASE SYMBOLS ♦	A B C D E F G H I J K L M N O P Q R S T U V W X Y Z		
NUMERALS	0 1 2 3 4 5 6 7 8 9		
CHARACTER	NAME	CHARACTER	NAME
	Space (Nonprinting)	;	Semicolon
!	Exclamation Point	<	Less Than
"	Quotation Marks (Diaeresis)	=	Equals
#	Number Sign	>	Greater Than
\$	Dollar Sign	?	Question Mark
%	Percent	@	Commercial At
&	Ampersand	[	Opening Bracket
'	Apostrophe (Acute Accent)	\	Reverse Slant
(	Opening Parenthesis	]	Closing Bracket
)	Closing Parenthesis	♦♦ ↑	Up Arrow
♦ *	Asterisk	♦♦ ←	Left Arrow
+	Plus	`	Grave Accent
,	Comma (Cedilla)	{	Opening Brace
-	Hyphen (Minus)		Vertical Line
.	Period (Decimal Point)	}	Closing Brace
/	Slant	~	Equivalent (Overline)
:	Colon	!	Parity Error
♦ Characters differing slightly from those of display character set.			
♦♦ Characters completely different from those in display character set.			

00849-3

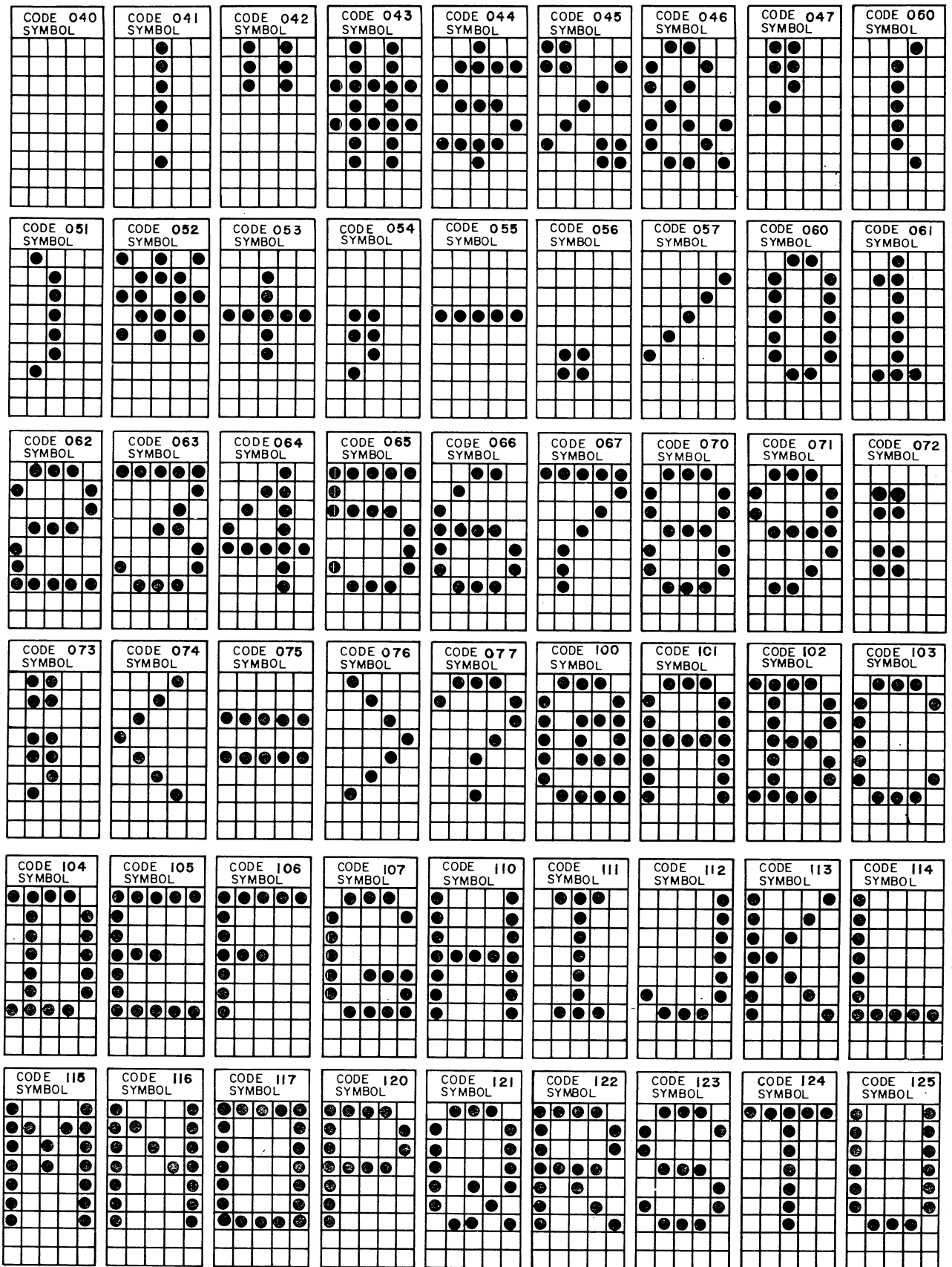

00958-1

Figure 4-3. Nonimpact Printer Character Repertoire (Sheet 1 of 2)

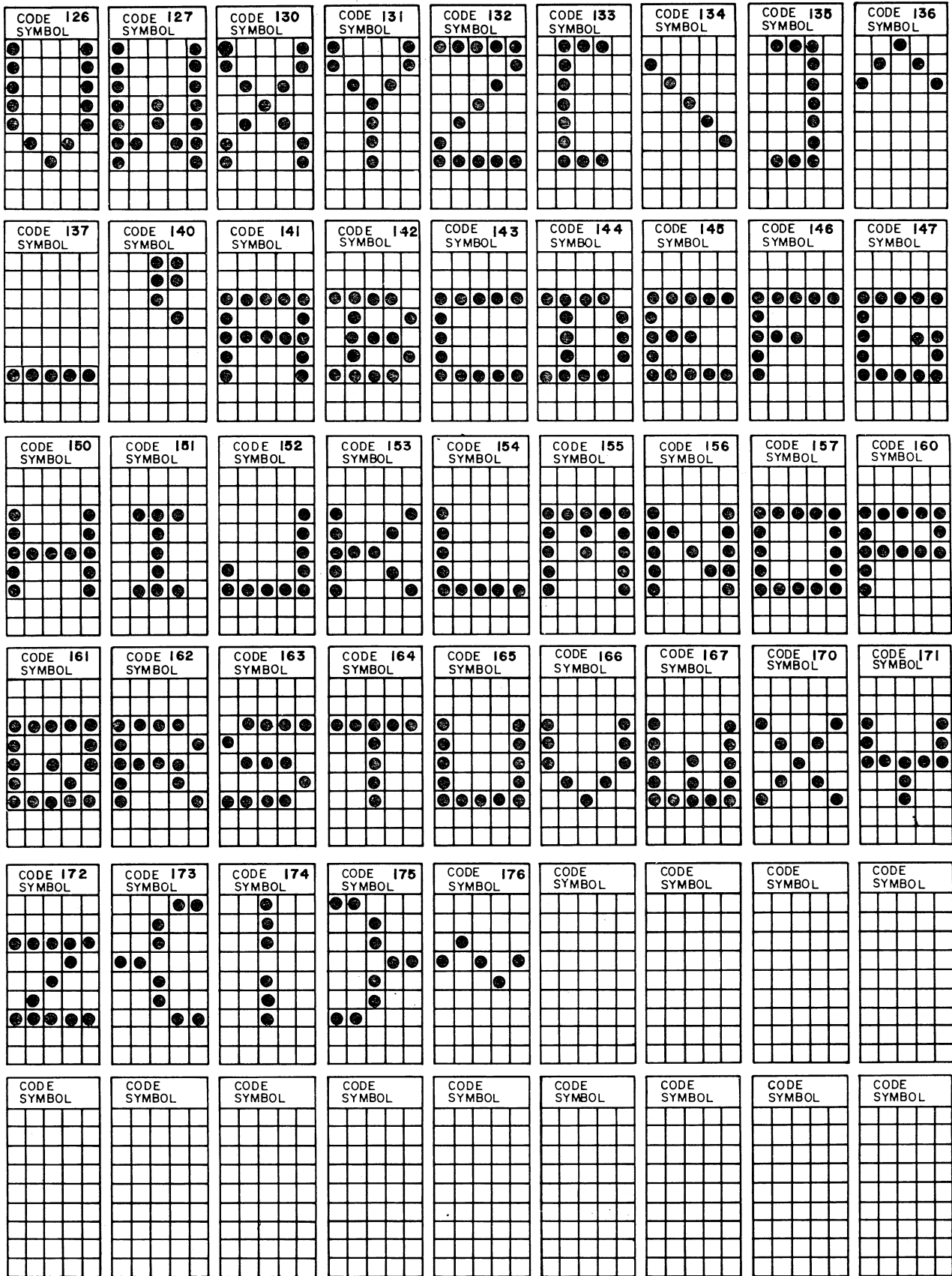

Figure 4-3. Nonimpact Printer Character Repertoire (Sheet 2 of 2)

00959-1

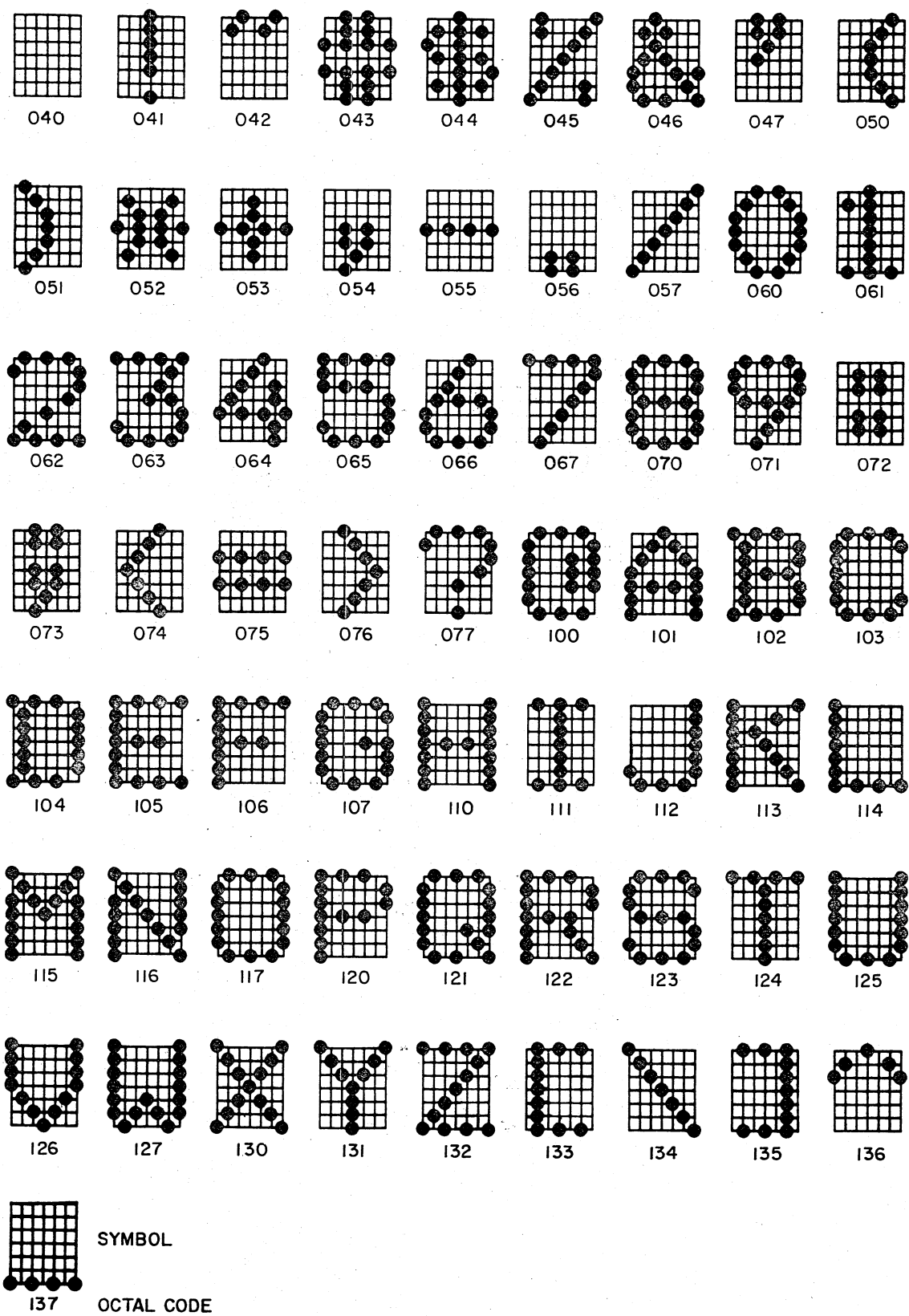

Figure 4-4. Impact Printer Character Repertoire (Sheet 1 of 2)

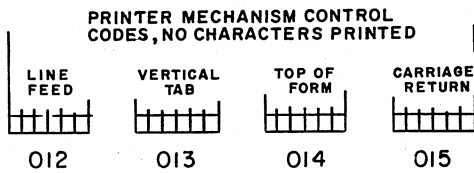
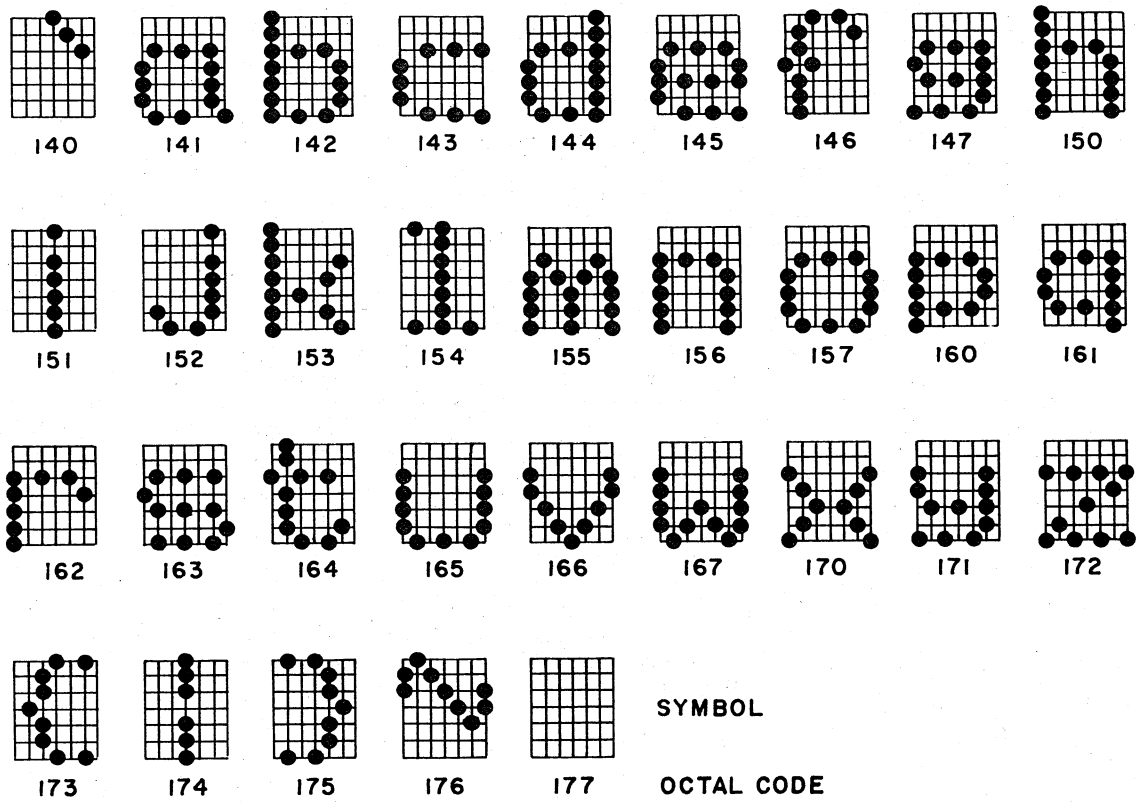

Figure 4-4. Impact Printer Character Repertoire (Sheet 2 of 2)

---

Proper care of equipment and regular cleaning of the equipment by the operator not only contributes to trouble-free operation of the terminal, but also keeps it looking neat and attractive, thereby promoting a pleasant and businesslike atmosphere. Cleaning should be scheduled when power to the terminal is turned off — just before system startup or just after system shutdown for the day. Perform the following steps weekly:

- 1) Remove dust accumulations from hard-to-reach nooks and crannies (for example, the keyboard and inside the printer) with a soft-bristled brush.

### CAUTION

Never use cleaners that contain ammonia or bleach. These cleaners discolor finished surfaces.

- 2) Clean cabinet exteriors of all devices with a damp, lint free cloth. Moisten cloth with a mild soap-and-water solution to remove any stubborn grime or smudges.
- 3) Clean display screen with a clean, soft cloth and a name-brand glass cleaner (any grit on the cloth will scratch the screen). If a spray is used, do not allow liquid to flow off screen (it is preferable to spray cloth rather than screen).
- 4) Clean printer top covers with a clean, soft cloth. The cloth may be moistened with a mild glass-cleaner solution, but it must be free of dust and grit to prevent scratching the transparent covers.



# INSTALLATION INSTRUCTIONS

A

---

This appendix provides information for crating, uncrating, and installing the various equipments that may comprise a terminal subsystem. Included also are instructions for handling PC cards.

## CRATING

To protect the terminal equipment from damage during transit, always prepare it for shipment using only approved materials and procedures. Proper materials may be obtained by contacting the nearest CDC representative or:

Control Data Corporation  
Corporate Traffic  
8100 34th Avenue South  
Minneapolis, Minnesota 55440

The following text and figures describe the crating procedures for each of the cabinet level equipments possible in a terminal subsystem. Information is also supplied for packing some of the component hardware used in the terminal subsystem.

To crate the keyboard display terminal, refer to figure A-1. If desired, a template is available for cutting out the polystyrene packing material. Order D-size drawing number 41035301 from CDC Corporate Traffic.

To crate the nonimpact and impact printers, and to package the PC card modules, refer to figures A-2 through A-5.

In shipping any other subassembly (video monitor, power supply, print mechanism, etc.), try to pack it in the carton in which its replacement came. Always unpack replacement items carefully so the packing materials can be reused in packing items to be shipped for repair.

## UNCRATING

The following paragraphs describe uncrating procedures for each of the cabinet level equipments that can comprise a terminal subsystem. In addition, they contain information for unpacking PC card modules and miscellaneous subsystem components. Remember to save packing materials for returning replaced items to repair centers.

CRATING NOTES:

- 1) USE CRATING KIT 41035800 WITH 41035801 END FRAMES (2) AND 41035802 EXTERIOR CONTAINER.
- 2) INTERLOCK FOAM BASE LEGS WITH END FRAMES.
- 3) PLACE END FRAMES WITH BASE LEGS ON DISPLAY.
- 4) PLACE DISPLAY WITH END FRAMES INTO CONTAINER.
- 5) INTERLOCK T-BLOCKS WITH END FRAMES.
- 6) LIFT TOP FLAPS ON END FRAMES AND INSTALL KEYBOARD WITH KEYS FACING DOWN.
- 7) SECURE CABLES IN END FRAME SLITS AS SHOWN.
- 8) CLOSE AND SEAL CONTAINER WITH 3-INCH WHITE REINFORCED BOX SEALING TAPE.

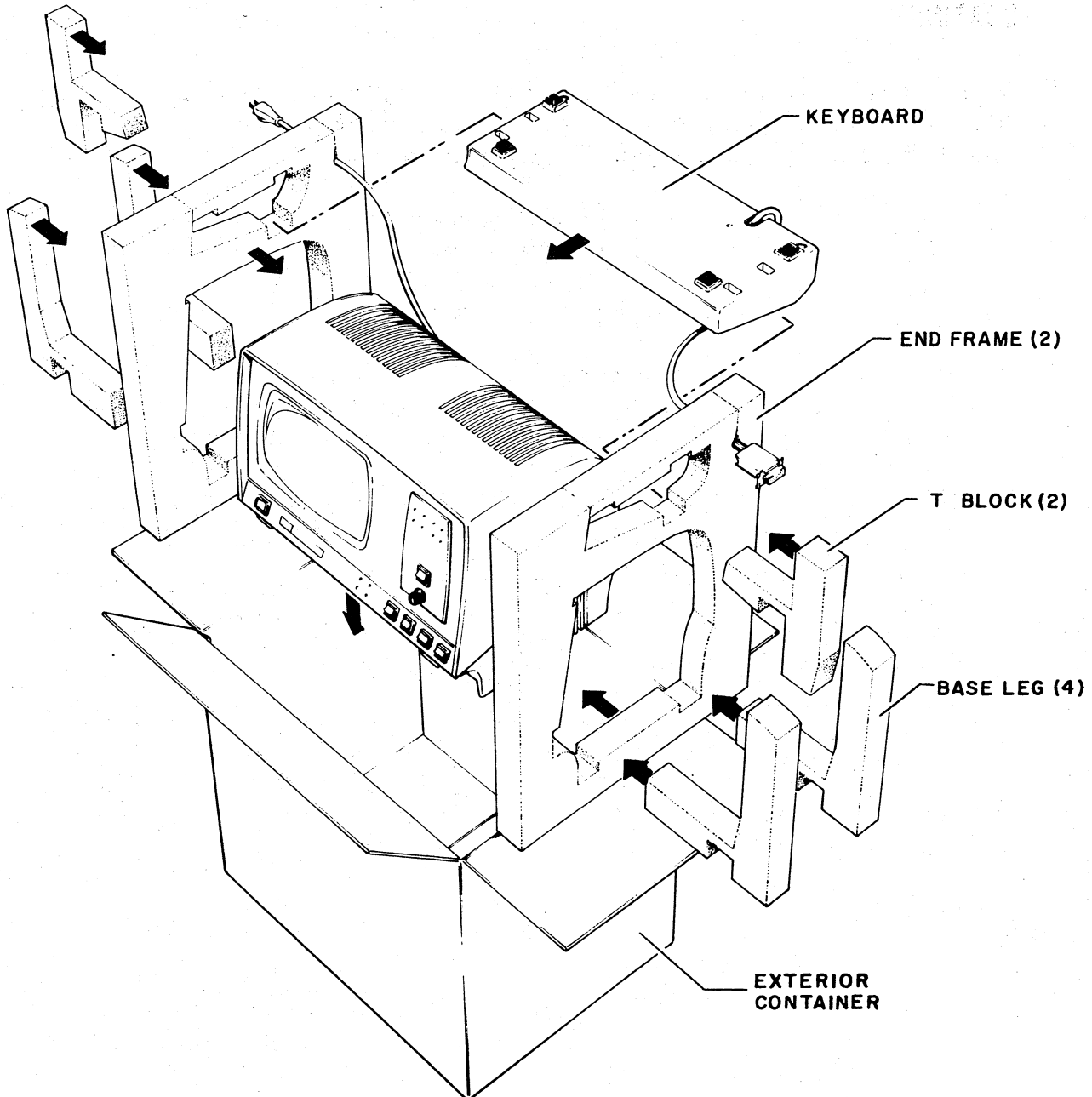

01945-1

Figure A-1. Crating and Uncrating the Display Terminal

CRATING NOTES:

- 1) USE CRATING KIT 59113100.
- 2) RESTRAIN PRINthead FROM SIDEWAYS MOVEMENT (SUCH AS TIE TO SIDE BY LOOPING SMALL RUBBERBAND AROUND HEAD AND ANY SECURE PROTRUSION ON PRINTER CHASSIS SIDE PLATE).
- 3) COIL POWER CORD NEATLY AND WRAP AROUND WITH TWO OR THREE LOOPS OF TAPE.
- 4) PLACE END CAPS ON PRINTER AND LOWER PRINTER WITH END CAPS DOWN INTO EXTERIOR CONTAINER.
- 5) CLOSE AND SEAL BOX FLAPS WITH REINFORCED BOX SEALING TAPE.

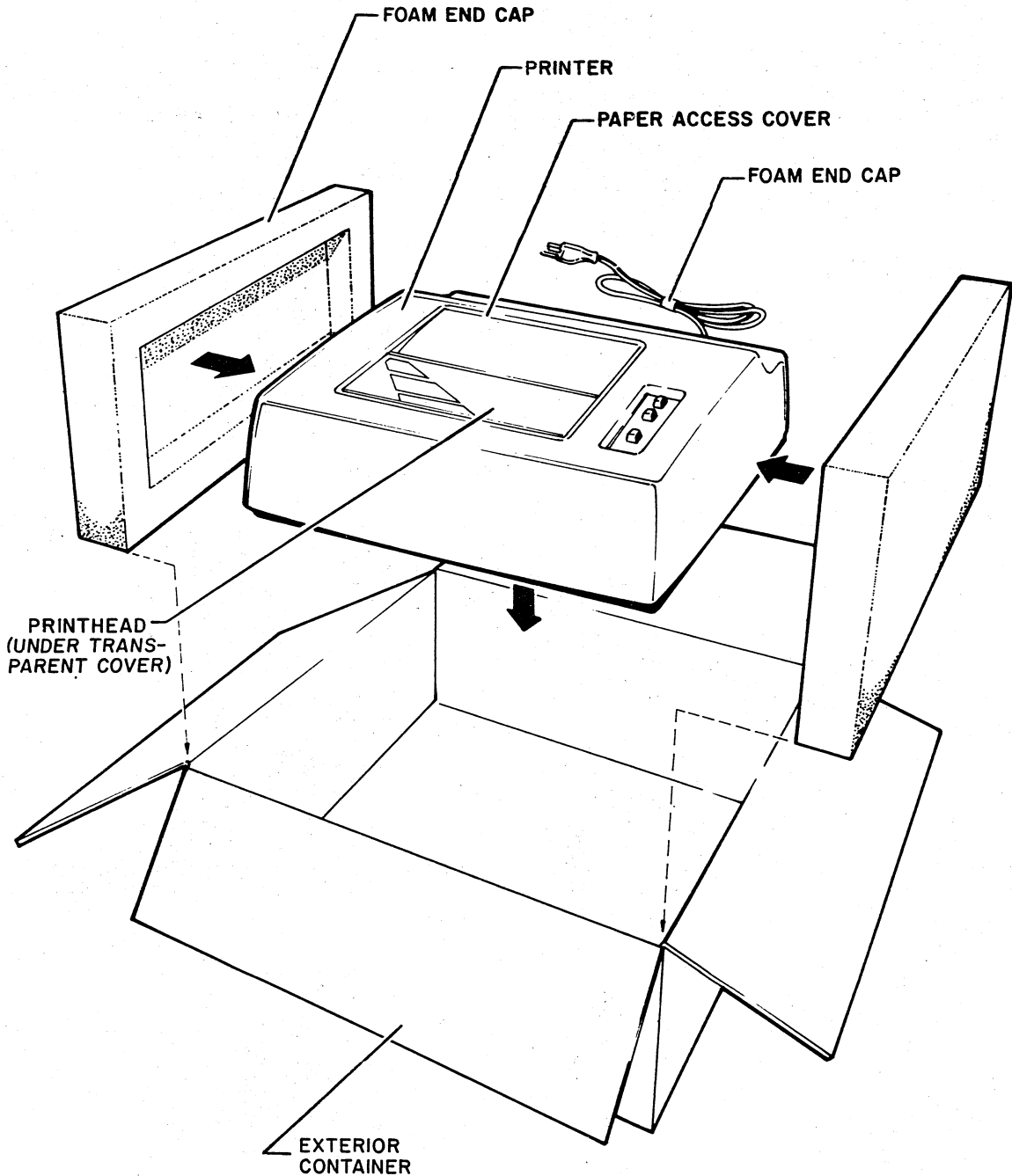

02064

Figure A-2. Crating and Uncrating the Nonimpact Printer

CRATING NOTES:

- 1) USE CRATING KIT 59125400.
- 2) SECURE PRINTER CHASSIS TO CABINET BASE BY INSTALLING TWO M6x8 SHIPPING SCREWS. INSTALL SCREWS FROM UNDER PRINTER IN HOLES PROVIDED.
- 3) ASSEMBLE EXTERIOR CONTAINER BOTTOM (59125413) USING FILAMENT TAPE TO SECURE FLAPS.
- 4) PLACE TWO LOWER END CUSHIONS (59125411) INTO BOTTOM ENDS OF CONTAINER.
- 5) POSITION PLASTIC DUST COVER (59125407), CLOSED END DOWN, INTO CONTAINER AND SPREAD OPEN END OVER CONTAINER RIM.
- 6) POSITION PRINTER IN DUST COVER SO IT MOUNTS SECURELY IN LOWER END CUSHIONS.
- 7) COIL CABLE BEHIND PRINTER.
- 8) PLACE FOUR DESICCANT BAGS (59124408) INTO PLASTIC DUST COVER WITH PRINTER AND HEAT SEAL TOP OF DUST COVER.
- 9) PLACE UPPER END CUSHIONS (59125412) INTO POSITION ON ENDS OF PRINTER CABINET.
- 10) CLOSE BOX FLAPS AND SECURE WITH FILAMENT TAPE (59136109).
- 11) PLACE PRINTER BOX ON SHIPPING SKID (59125408).
- 12) PLACE PACKAGED PEDESTAL (OPTIONAL) BOX ON TOP OF PRINTER BOX AND STRAP TO SKID USING STEEL STRAPPING (59196107), CLAMPS (59136108) AND CORNER PROTECTORS (59136123).

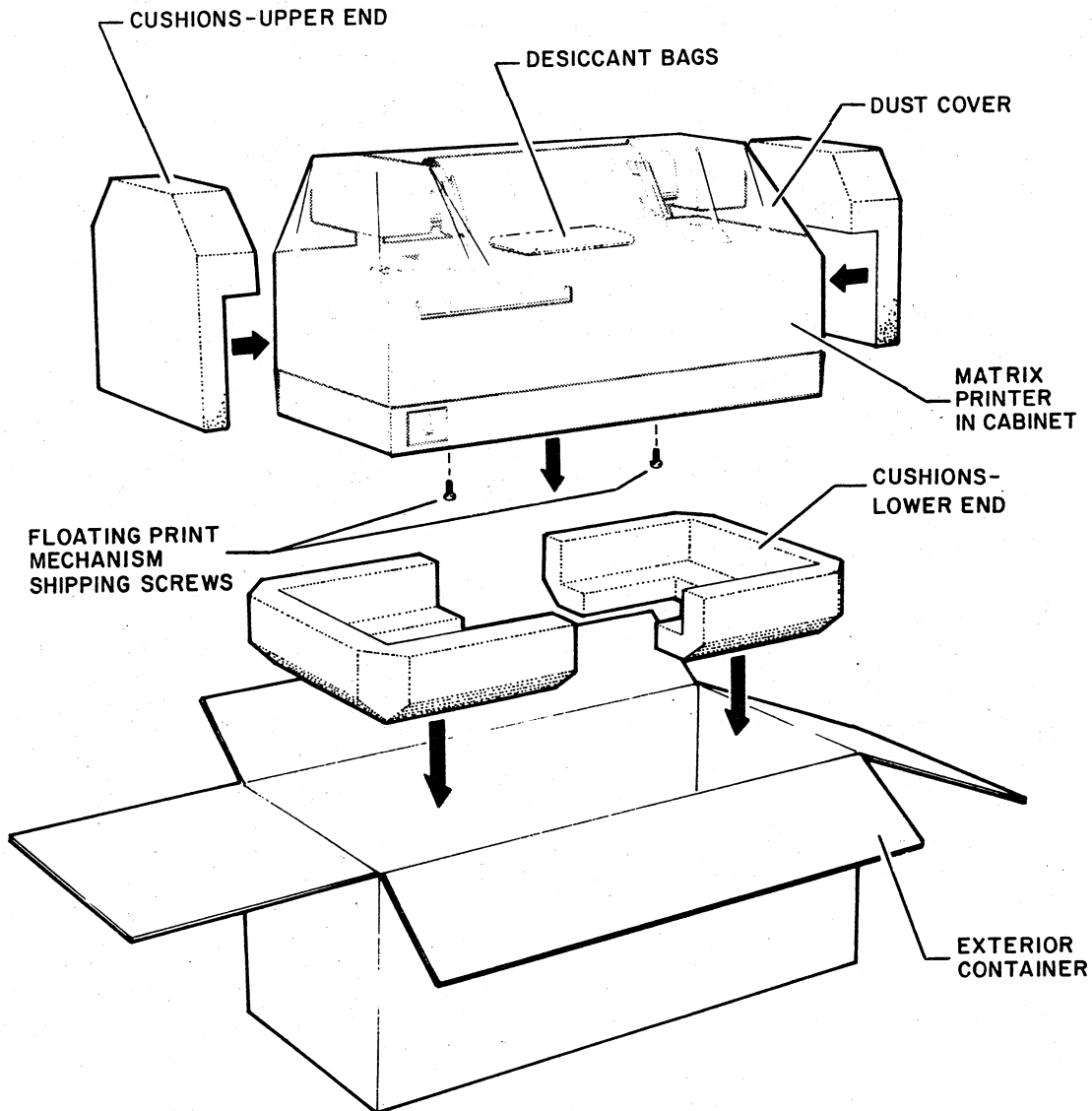

02207

Figure A-3. Crating and Uncrating the Impact Printer

CRATING NOTES:

- 1) USE CRATING KIT 59125600.
- 2) DISASSEMBLE PEDESTAL AND ENCLOSE EACH OF FOLLOWING IN PLASTIC BAGS (59125605):
  - LEFT UPRIGHT WITH LEFT PANEL ATTACHED.
  - RIGHT UPRIGHT WITH RIGHT PANEL ATTACHED.
  - BOTTOM FRAME CROSS-MEMBER.
- 3) ASSEMBLE EXTERIOR CONTAINER (59125601), USING CARTON-SEALING TAPE (59136111).
- 4) PLACE SEPARATE PLAIN PAD (59125603) IN BOTTOM OF CONTAINER.
- 5) PLACE LEFT AND RIGHT PEDESTAL UPRIGHTS INTO CONTAINER AS INDICATED WITH CREASED SHEET SEPARATOR (59125602).
- 6) INSERT ANOTHER SEPARATOR PLAIN PAD (59125603).
- 7) PLACE PEDESTAL BACK PANEL AND BOTTOM FRAME CROSS-MEMBER INTO CONTAINER AND SECURE WITH TAPE.
- 8) INSERT ANOTHER SEPARATOR PLAIN PAD (59125603).
- 9) ASSEMBLE INTERIOR BOX USING CARTON-SEALING TAPE (59136111).
- 10) PLACE ASSEMBLY HARDWARE IN INTERIOR BOX AND SEAL WITH CARTON-SEALING TAPE (59136111).
- 11) PLACE INTERIOR BOX AND ASSEMBLY INSTRUCTIONS INTO EXTERIOR CONTAINER.
- 12) SEAL FLAPS OF EXTERIOR CONTAINER WITH CARTON-SEALING TAPE.

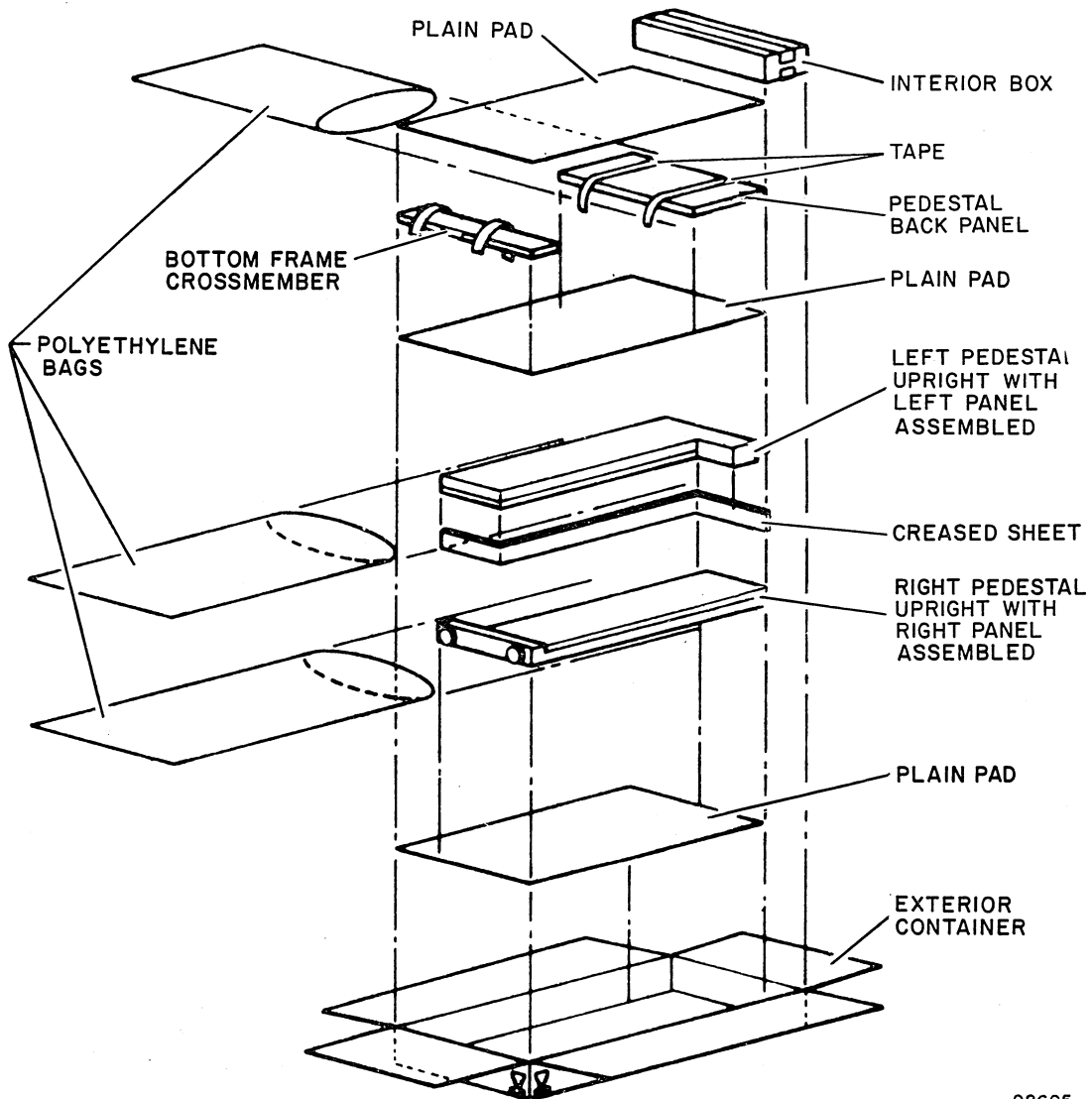

02605

Figure A-4. Crating and Uncrating the Impact Printer Pedestal

CRATING NOTES:

- 1) PRESENCE OF STATIC ELECTRICITY MAY DESTROY SENSITIVE MOS CIRCUITS, SUCH AS ROM OR STATIC SHIFT REGISTER CIRCUITS. ANY CIRCUIT CARD CONTAINING MOS CIRCUITS (STATIC-ELECTRICITY SENSITIVE) REQUIRES SPECIAL HANDLING. USE "MOS CIRCUIT HANDLING PRECAUTIONS" AND WRAP CARD IN STATIC-PROTECTIVE MATERIAL, SUCH AS, ALUMINUM FOIL. ALSO REFER, IF DESIRED, TO CDC SPECIFICATION 16033100 WHICH DESCRIBES SPECIAL HANDLING FOR MOS TYPE CIRCUITS.
- 2) ONLY ONE CARD MAY BE PLACED IN A PADDED BAG. SLIDE A CIRCUIT CARD IN AN APPROPRIATE SIZE BAG (#2 SMALL CARD, #5 MEDIUM, AND #7 LARGE).
- 3) PACK EACH BAGGED CARD, OR SEVERAL BAGS (EACH WITH ONE CARD), IN A CORRUGATED SHIPPING CONTAINER. FILL ANY VOIDS WITH CUSHIONING PACKING MATERIAL.

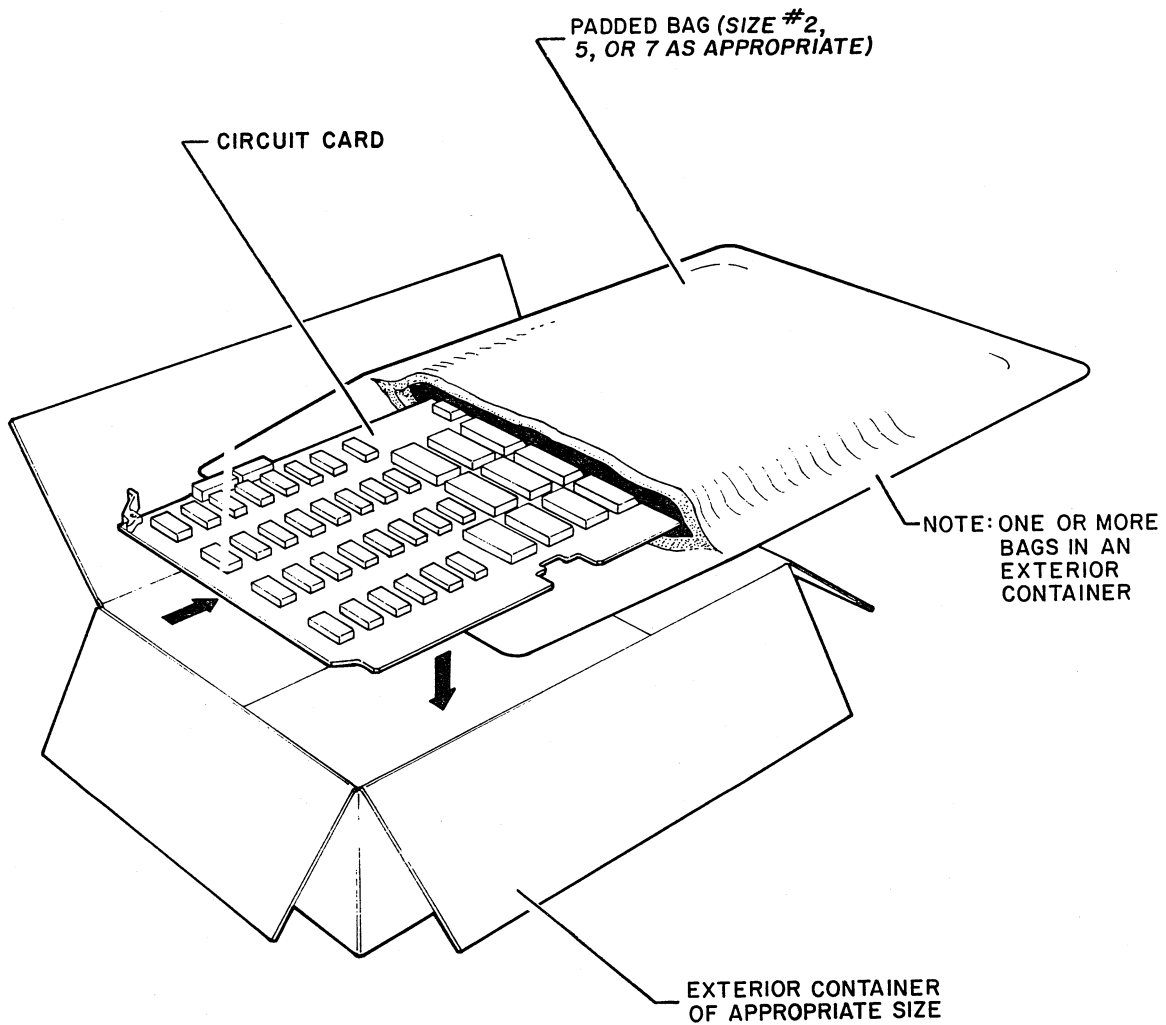

02208

Figure A-5. Packing of PC Card Modules

## **KEYBOARD DISPLAY**

To uncrate the keyboard display, refer to figure A-1 and proceed as follows:

- 1) Open top of exterior container and lift cables secured in the end frame slits of packaging material.
- 2) Lift top flaps of end frames and remove keyboard.
- 3) Remove two T-blocks interlocked in the end frames.
- 4) Remove display, with end frames attached, from exterior container.
- 5) Remove end frames and any remaining packing material from display.
- 6) Inspect display and keyboard for any shipping damage.

## **NONIMPACT PRINTER**

To uncrate the nonimpact printer, refer to figure A-2 and proceed as follows:

- 1) Open top of shipping carton and remove any packing material.
- 2) Lift printer, including end caps, from carton.
- 3) Open end caps from printer and remove any poly covering.
- 4) Open paper-access cover and remove restraint from printhead. To reach the restraint it may be necessary to remove the cabinet top cover by loosening the two 1/4-turn retaining screws at the rear of the cabinet. This depends on the type of printhead restraint used and on where it is positioned.
- 5) Inspect the printer for possible damage during shipment.

## **IMPACT PRINTER**

To uncrate the impact printer, refer to figure A-3 and proceed as follows:

- 1) Cut and remove steel strapping and remove pedestal package (optional) from top.
- 2) Open printer box and remove upper end cushions.
- 3) Carefully cut open plastic dust cover and remove any material from top of printer.

- 4) Reach into dust cover and lift out the printer, note printer weighs about 78 lb (35 kg).
- 5) Carefully place printer on a solid, level surface.
- 6) Remove two screws securing cabinet base plate to floating printhead.
- 7) Inspect printer for possible damage during shipment.
- 8) If pedestal is included, refer to figure A-4, and open pedestal box, remove assembly instruction sheet, remove packing materials from pedestal parts, and assemble pedestal according to instruction sheet.
- 9) Attach printer to pedestal (if included) according to instruction sheet.

### **PC CARD MODULES**

To unpack any circuit card modules, refer to figure A-5 and proceed as follows:

- 1) Open exterior corrugated box.

#### CAUTION

Follow precautions for handling MOS circuits to avoid damage via electrostatic discharge.

- 2) Open envelope(s) and remove card(s).
- 3) Verify that card(s) are clean of all packing material and inspect for possible shipping damage.

### **MISCELLANEOUS SUBSYSTEM COMPONENTS**

When unpacking any replacement components for a terminal subsystem equipment, always proceed carefully and remember the following.

- 1) Preserve the condition of the shipping container and packing material for use with the component to be returned for repair.
- 2) Observe the manner in which the received component is packed so the component to be returned can be packed in the same manner.

## INSTALLATION

The following paragraphs describe proper installation of the various equipments that may comprise a terminal subsystem. Instructions are given for the:

- Keyboard Display
- Nonimpact Printer
- Impact Printer

### KEYBOARD DISPLAY INSTALLATION

The following procedure gives the steps for installing the display terminal.

- 1) Remove the keyboard display from packing container (see uncrating instructions).\*
- 2) Attach free end of keyboard cable to connector in recess under right-front corner of display module. Secure keyboard connector to display connector via two screws at each side of keyboard connector. Keyboard need not be positioned into display module keyboard recess at this time.
- 3) Remove cabinet hood of display module by unscrewing two mounting screws at rear of hood, figure A-6, and sliding the hood back and lifting it up.

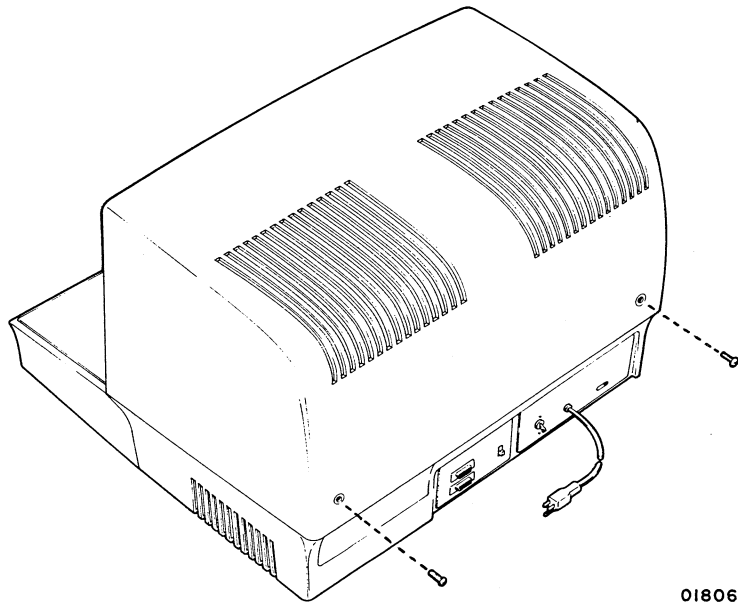

Figure A-6. Cabinet Hood Removal

\* Terminal requires a minimum of 4.0 in (10.2 cm) clearance at both sides and top for adequate cooling. Also, when operating the terminal assure that nothing is placed on top of or to the side of terminal so as to block air intake (each side) or exhaust (top) vents.

- 4) Remove logic PC card cover plate on decal side of card chassis by removing two retaining screws holding plate to chassis.
  
- 5) Internal switches are preset at the factory. Verify settings of baud rate switches, internal control switches, and interface jumpers and alter them, if required, to suit particular installation requirements. Refer to table A-1 and figure A-7 for factory settings and for switch and jumper locations. Use ballpoint pen to alter switch settings if necessary. Use needle nose pliers to alter interface jumpers if necessary.\* Once desired settings are made, mark these settings in on the SITE boxes of the decal on the logic card cover plate, see figure A-7.

TABLE A-1. FACTORY SETTINGS FOR PC BOARD SWITCHES

CONTROL	SETTING
HIGH RATE Switches	9600 baud
LOW RATE Switches	110 baud
AUTO LINE FEED Switch	Disabled
MARK PARITY Switch	Enabled
50 HZ Switch	Enabled if terminal 220/240-V ac type
SWITCH RTS Switch	Enabled
CONSTANT DTR Switch	Enabled
INTERNAL TEST Switch	Disabled
X/Y POSITION Switch	Disabled
CURRENT LOOP Switch	Disabled
Interface Jumpers	Voltage level interface

\* AUTO LINE FEED switch should not be enabled if a printer peripheral is used on the terminal. If a nonimpact printer is used, it requires a 300 baud transmission rate and an even parity selection. Any impact printer can be internally set to accept 150, 300, 600, or 1200 baud rates, and either odd-, even-, or no-parity transmission words. Modems not having interface signals listed in table A-2 may require CURRENT LOOP switch to be set to enable position.

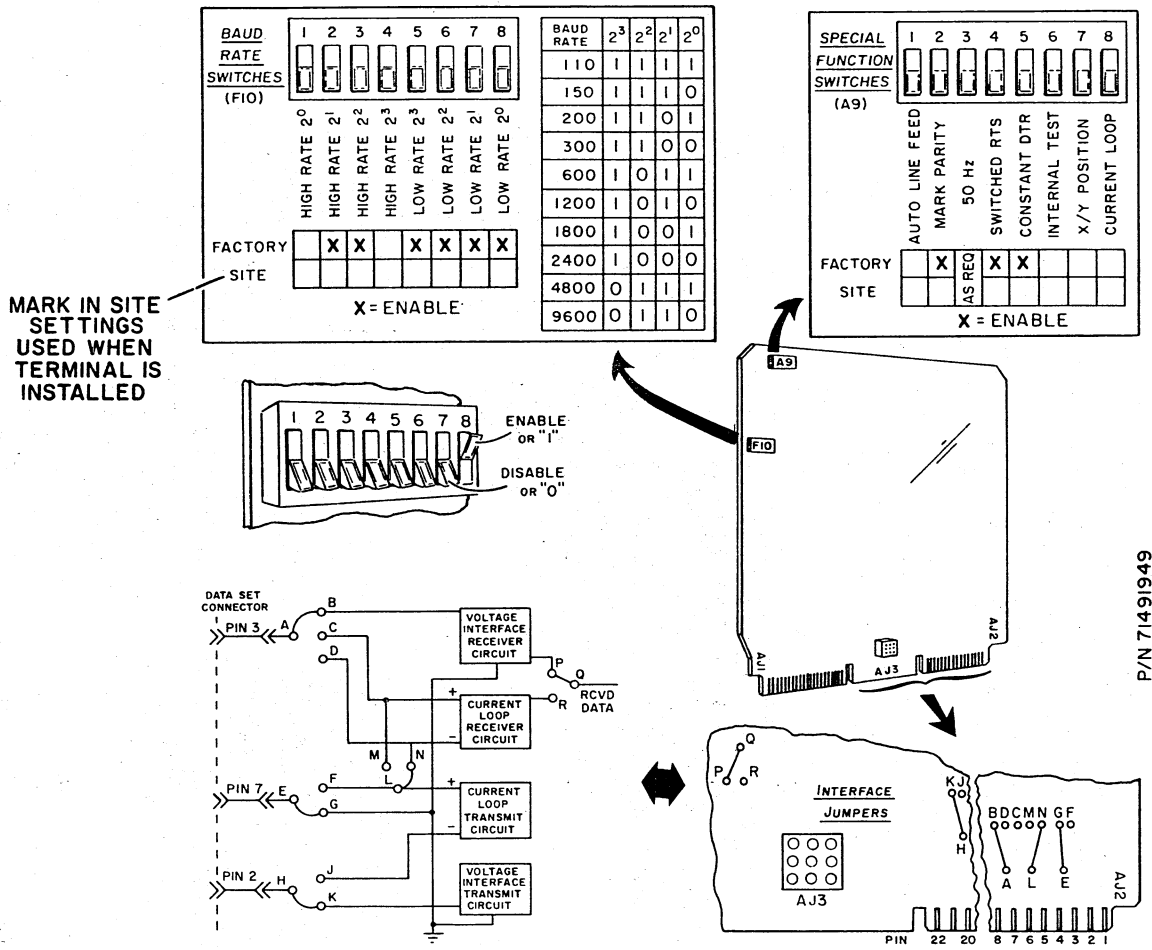

MARK IN SITE SETTINGS USED WHEN TERMINAL IS INSTALLED

P/N 71491949

02094

Figure A-7. Internal Switches and Controls

- 6) For 220/240-volt, 50-Hz terminals check for correct connection of LOW/NORMAL connector to transformer-primary connector CP2/CJ2, see figure A-8. For a 195 to 246-V ac input power range (nominal 220 V), a LOW line connector is used; for 216 to 268-V ac input power range (nominal 240 V), a NORMAL connector is used. Figure A-8 also indicates the color code used for the hot (brown), neutral (blue), and chassis ground (green/yellow) wires in the line cord of 220/240-V terminals; these terminals come without power plugs so attach appropriate power plug according to the schematic diagram in figure A-8.
- 7) Replace logic PC card cover plate by positioning plate in place (decalside out) and by installing the two retaining screws removed in step 4.
- 8) Replace cabinet hood and hood retaining screws.

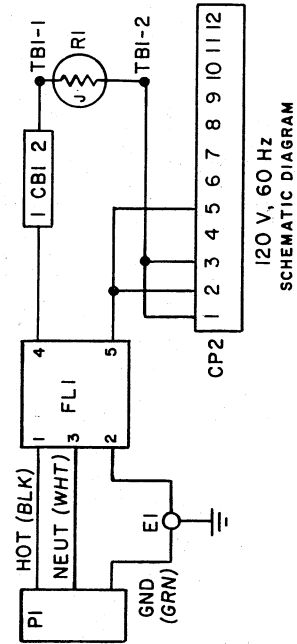
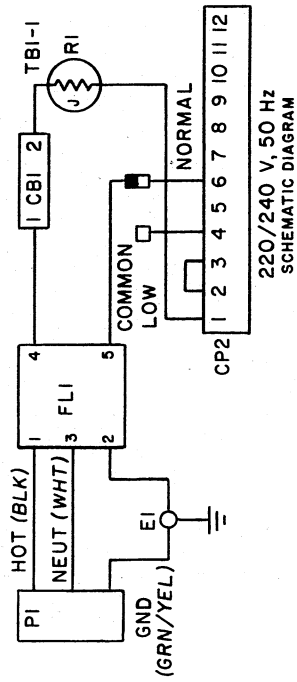
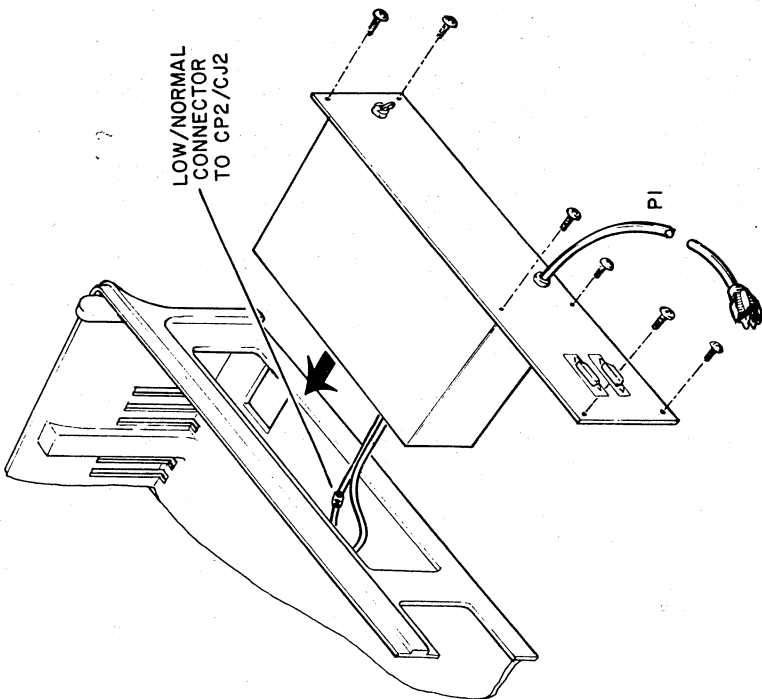
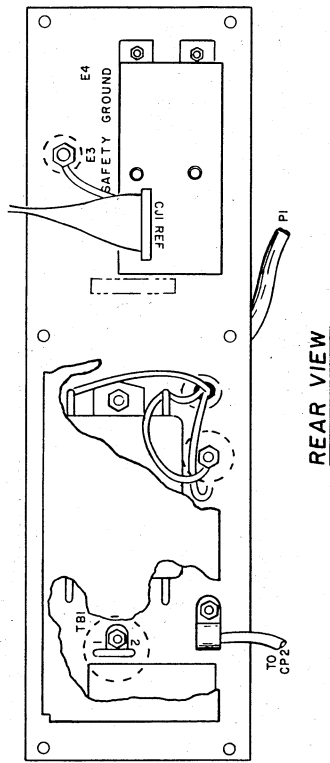
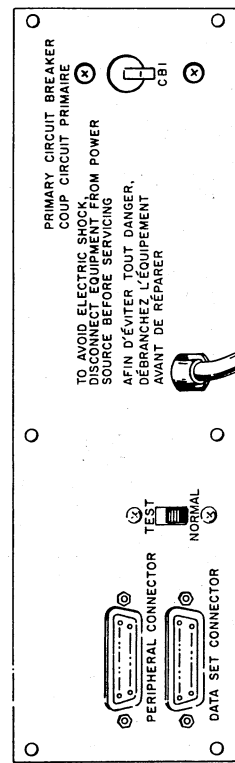

02604

Figure A-8. Rear-Panel Removal and Connections

- 9) Install keyboard under front of display module by raising front edge of display module, sliding rear edge of keyboard module back under and into recess in display module, and then lowering front edge of display module. Keyboard cable should slip back under display module for proper installation.
- 10) Verify that all keyboard control switches are set to their desired operating positions. Refer to main body of this manual for control switch functions if required.

#### NOTE

Both rear panel connectors (DATA SET CONNECTOR and PERIPHERAL CONNECTOR) are equivalent to ITT-Cannon DBC-25S connectors and therefore, require the equivalent of ITT-Cannon DBC-25P as a mating connector.

The following tables and figures show the pin assignments required on a mating connector for: 1) an RS-232-C/CCITT V.24 voltage level connection to the DATA SET CONNECTOR, table A-2; 2) the PERIPHERAL CONNECTOR, table A-3; 3) connection of a unipolar, full-duplex current loop channel to the DATA SET CONNECTOR, figure A-9; and 4) connection of a unipolar half-duplex, current loop channel to the DATA SET CONNECTOR, figure A-10.

Complete cables with DBC-25P connectors on both ends are available from CDC under part numbers: 61406100, 10.5 ft (4.6 m); 61406101, 20.5 ft (7.6 m); 61406102, 30 ft (9.1 m); 61406103, 40 ft (12.2 m); and 61406104, 50 ft (15.2 m).

FTZ licensed versions of the terminal use cable part numbers: 61406110, 10.5 ft (4.6 m); 61406111, 20.5 ft (7.6 m); 61406112, 30 ft (9.1 m); 61406113, 40 ft (12.2 m); and 61406114, 50 ft (15.2 m).

- 11) Make appropriate connections between terminal and communication channel, and if used, attach cable for peripheral printer per requirements given in preceding note and in referenced figures and tables. Connector receptacles on terminal accept securing screws from mating connector; secure cables via these screws (2 each).
- 12) Install other terminal subsystem equipments before plugging in keyboard display terminal to ac power outlet or attempting to turn terminal power on.

TABLE A-2. VOLTAGE LEVEL CHANNEL (RS-232-C/CCITT V.24)  
INTERFACE CONNECTOR PIN ASSIGNMENTS

PIN NUMBER	CCITT	EIA	SIGNAL NAME	ORIGIN
1	101	AA	Protective Ground	Modem/Terminal
2	103	BA	Transmitted Data	Terminal
3	104	BB	Received Data	Modem
4	105	CA	Request to Send (RTS)	Terminal
5	106	CB	Clear to Send (CTS)	Modem
6	107	CC	Data Set Ready (DSR)	Modem
7	102	AB	Signal Ground	Modem/Terminal
8	109	CF	Received Line Signal Detector (CO)	Modem
9	---	--	Not Used	-----
10	---	--	Not Used	-----
11	---	--	Secondary Request to Send (SRTS)*	-----
12	122	SCF	Secondary Received Line Signal Detector (SCO)	Not Used
13	121	SCB	Secondary Clear to Send (SCTS)	Not Used
14	118	SBA	Secondary Transmitted Data	Not Used
15	114	DB	Transmission Signal Element Timing	Not Used
16	119	SBB	Secondary Received Data	Not Used
17	115	DD	Receiver Signal Element Timing	Not Used
18	---	--	Not Used	-----
19	120	SCA	Secondary Request to Send (SRTS)	Terminal
20	108.2	CD	Data Terminal Ready (DTR)	Terminal
21	110	CG	Signal Quality Detector	Not Used
22	125	CE	Ring Indicator	Not Used
23	111	CH	Data Signal Rate Selector	Terminal
24	113	DA	Transmit Signal Element Timing	Not Used
25	---	--	Not Used	-----

\* Data Set Connector has pin 11 jumpered to pin 19.

TABLE A-3. PERIPHERAL CONNECTOR PIN ASSIGNMENTS

PIN NUMBER	CCITT	EIA	SIGNAL NAME	ORIGIN
1	101	AA	Protective Ground	Printer/Terminal
2	---	--	Not Used	-----
3	104	BB	Received Data	Terminal
4	---	--	Not Used	-----
5	---	--	Not Used	-----
6	107	CC	Data Set Ready (DSR)	Terminal
7	102	AB	Signal Ground	Printer/Terminal
8	109	CF	Received Line Signal Detector (CO)	Terminal
9	---	--	Not Used	-----
↓	↓	↓	↓	↓
25	---	--	Not Used	-----

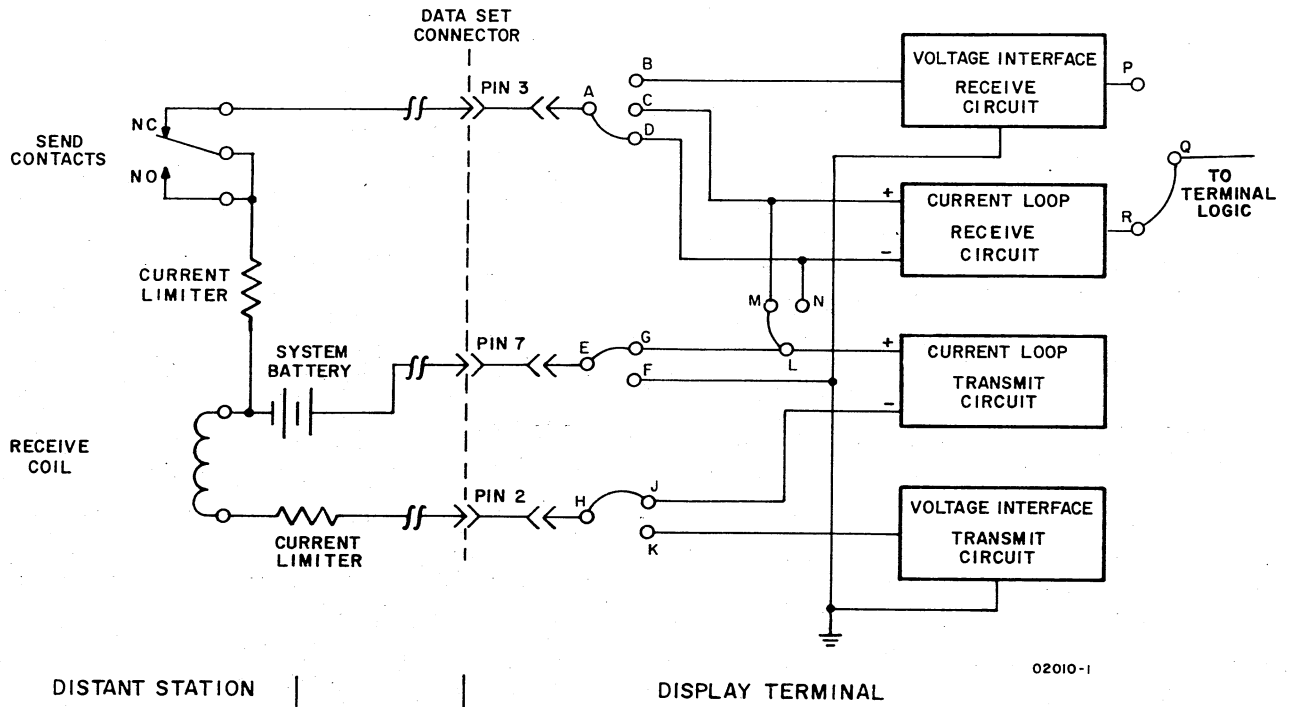

Figure A-9. Data Set Connector Pin Assignments for Unipolar, Full-Duplex, Current Loop Communication Channel\*

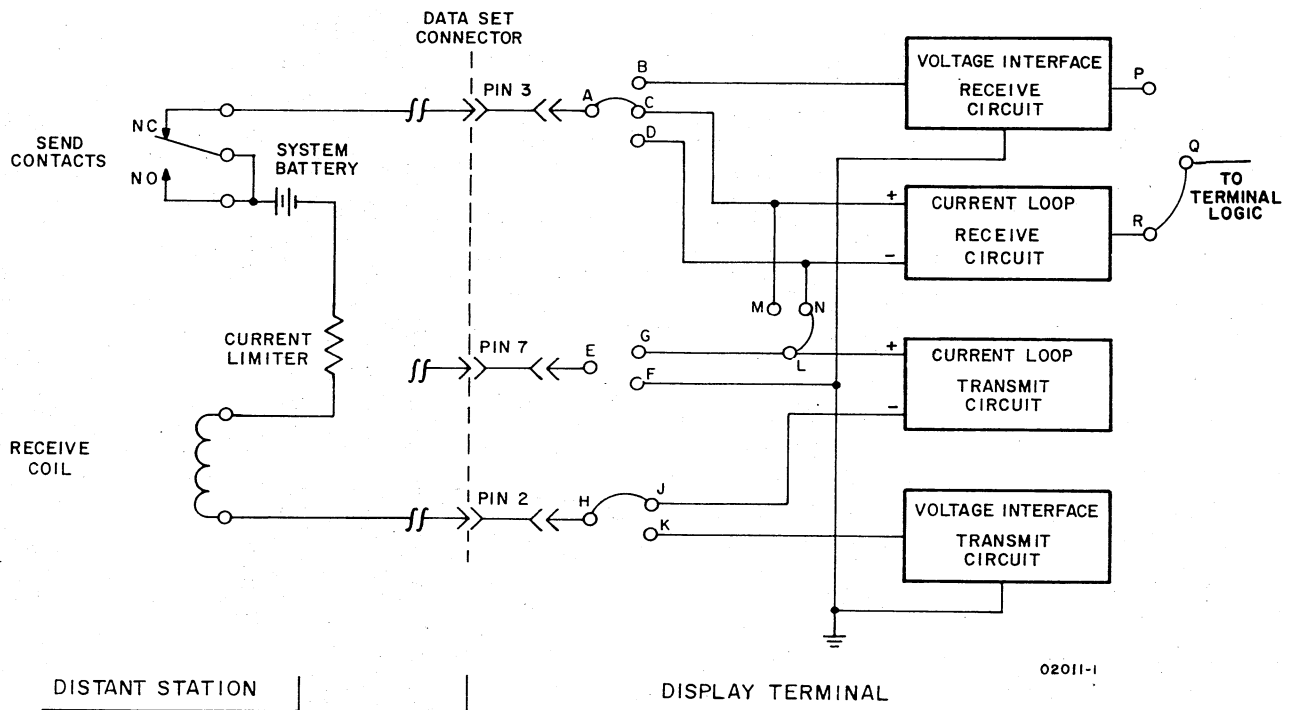

Figure A-10. Data Set Connector Pin Assignments for Unipolar, Half-Duplex, Current Loop Communication Channel\*

\* CURRENT LOOP CIRCUITS ARE ONLY AVAILABLE IN TERMINALS WITH THAT FEATURE INSTALLED. SYSTEM BATTERY IS 24 V dc AND CURRENT LIMITERS ARE SELECTED FOR 20-MILLIAMPERE FLOW.

## NONIMPACT PRINTER INSTALLATION

If a nonimpact printer is supplied as part of the terminal configuration, proceed with the following installation procedure. If, however, an impact printer is furnished, skip to the following Impact Printer Installation heading.

- 1) Remove printer unit from shipping container according to the preceding uncrating instructions.
- 2) Place printer unit near its associated keyboard display terminal. Be sure to allow space for maintaining printer unit and for performing such routine operations as paper loading. When installed, the unit should have at least 3 inches clearance on each side and at the back, and at least 2 feet of overhead clearance.
- 3) Connect RS-232-C/CCITT V.24 type I/O cable from rear of display terminal PERIPHERAL CONNECTOR to printer rear panel connector. Refer to notes for step 11 of keyboard display terminal installation if necessary.
- 4) Load/check paper roll in printer. Refer to main body of this manual for paper type and loading instructions if necessary.
- 5) Move single-line/double-line space switch near right side of paper-feed mechanism and just to the left of control panel to desired operating position. Moving slide switch toward back of printer selects single-line spacing, and moving it toward front of printer selects double-line spacing.
- 6) If 220/240-V ac, 50-Hz terminal installation, attach power plug to printer line cord as noted in step 6 of keyboard display installation procedures.
- 7) Plug power cord into appropriate ac power outlet.
- 8) Assure printer power is off by checking ON switch; switch is up when printer is off.

This completes installation procedures for the nonimpact printer. Connection of a modem to a common carrier communication facility is normally carried out by personnel from the company supplying the facility. As noted previously, the connector on the communication facility end of the terminal data set connector cable is RS-232-C/CCITT V.24 compatible, see table A-2. Power on the operating procedures are described in the main body of this manual.

## IMPACT PRINTER INSTALLATION

If an impact printer is furnished as part of the terminal installation, perform the following installation procedures. If a nonimpact printer is supplied, see the preceding nonimpact printer installation procedures.

- 1) Remove the printer unit from its shipping container according to the preceding uncrating instructions.
- 2) Place the unit near its associated keyboard display terminal, but be sure to allow space around the printer for carrying out routine maintenance and operating procedures. The spacing shown in figure A-11 is recommended as a minimum.

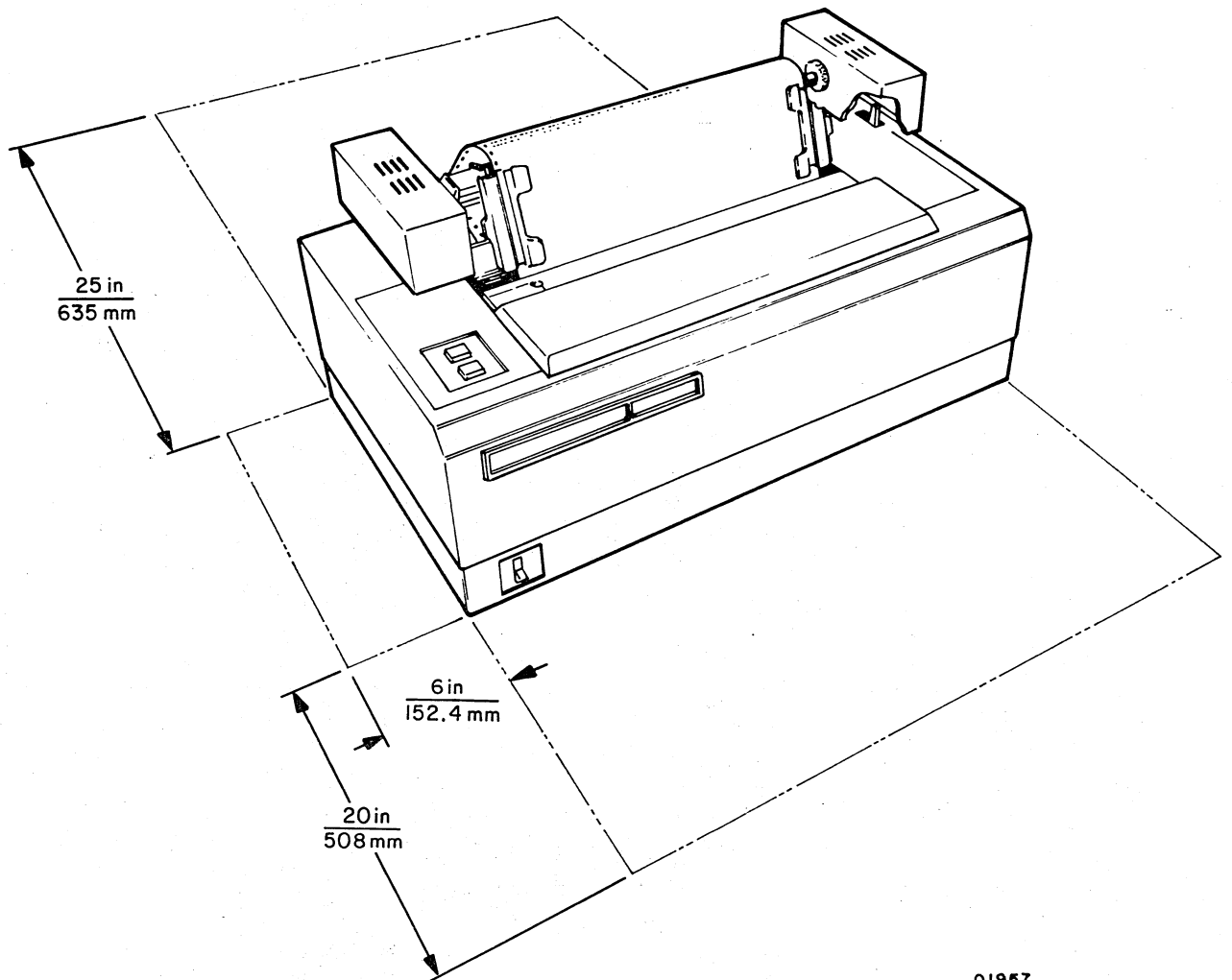

01957

Figure A-11. Impact Printer Access Space

- 3) Connect RS-232-C/CCITT V.24 type I/O cable from rear of display terminal PERIPHERAL CONNECTOR to the printer rear panel connector. Refer to notes for step 11 of keyboard display terminal installation if necessary.
- 4) Open rear access panel of printer by turning four twist-lock fasteners located along the top and side of backpanel 1/4 turn counterclockwise.
- 5) Identify RS-232-C interface board, figure A-12, and then remove this board from chassis by releasing the thumb-lever friction clamps at each side of the board and pulling the board out of the chassis.
- 6) Using figure A-13 as a guide, set the printer baud rate and parity select switches to match those of the keyboard display (see step 5, and its associated note, of the keyboard display installation procedures). Baud rate for terminals using an impact printer should not be set to exceed 1200 baud.

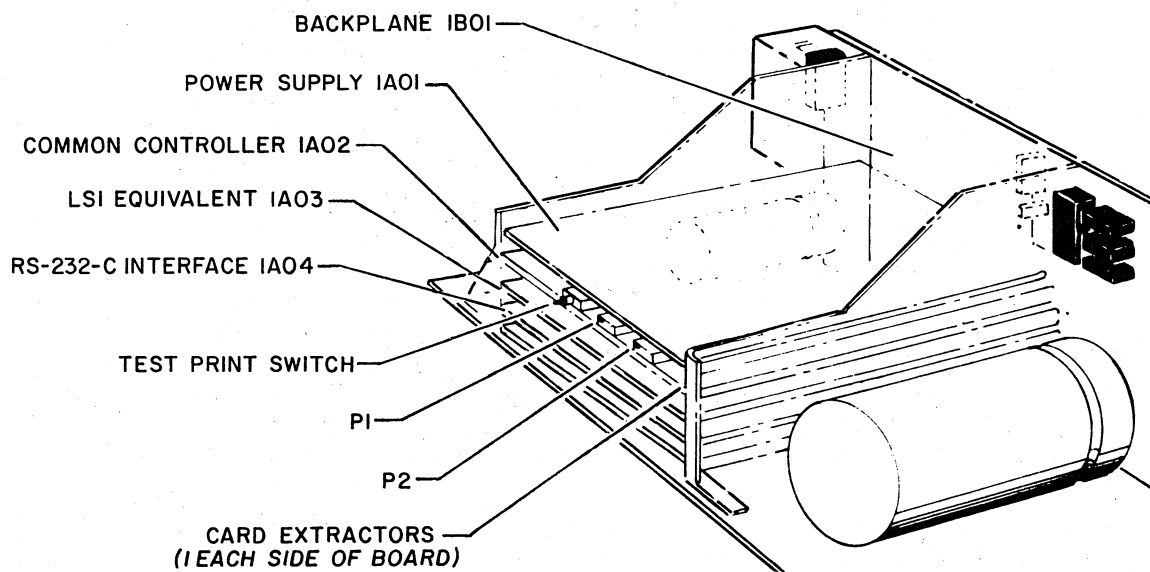

02212

Figure A-12. Impact Printer PC Board Locations

- 7) Set data bit switches (and jumper) to correspond with the parity selection in the preceding step: if odd or even parity selected, select 7 data bits; if no parity selected, select 8 data bits.
- 8) Remove jumpers for auto answering and reverse channel; alarm jumpers and buffer overflow jumper are optional (user's option).
- 9) Replace RS-232-C interface board in printer logic chassis (see figure A-12) by sliding it into place, and then seating board in chassis receptacle by engaging card extractors.



- 10) Close rear panel of printer cabinet and secure it by turning twist-lock fasteners 1/4 turn clockwise.
- 11) Assure power ON/OFF rocker switch on printer front panel is in OFF position.
- 12) If 220/240-V ac, 50-Hz terminal installation, attach power plug to printer line cord as noted in step 6 of keyboard display installation procedures.
- 13) Plug ac power cord into appropriate site power outlet.
- 14) See main body of this manual for paper loading, ribbon installation, and checking of the printer format tape.

This completes installation procedures for the impact printer. Connection of a modem to a common carrier communication facility is normally carried out by personnel from the company supplying the facility. As noted previously, the connector on the communication facility end of the terminal data set connector cable is RS-232-C/CCITT V.24 compatible, see table A-2. Power on and operating procedures for the impact printer and the keyboard display terminal are described in the main body of this manual.

## IMPACT PRINTER PRINT RATES

B

This appendix discusses the print rate of the impact printer. In the main body of this text, it was stated that the impact printer can accept and print received data from a 1200 baud communication facility. While this statement is true, it requires some clarification.

The impact printer is available in two different versions: one having only a 132-character print line buffer, and the other having both a 132-character print line buffer and a 1024-character print data buffer. The impact printer used in the 752 terminal has the additional 1K print data buffer. It can, therefore, accept data at rates much greater than 1200 baud (120 characters per second) up until the point at which the buffer is filled. Once the buffer is filled, both printers, buffered and unbuffered, print data at exactly the same rate. This print rate, however, is not fixed but is dependent on the length of the print line being printed. The relationship between print line length or characters per line (CPL) and print rate or lines per minute (LPM) is shown in figure B-1.

From figure B-1, notice the maximum print rate occurs when printing full length print lines of 132 characters per line and that shorter print lines cause the print rate to drop off somewhat. Referring to figure B-1 and using print line lengths of 132, 80, and 20 characters as examples, the following calculations show the effects of line length on the actual print rate.

$$132 \text{ CPS} \times 55 \text{ LPM} = 7260 \text{ CPM, or about } 120 \text{ CPS}$$

$$80 \text{ CPS} \times 74 \text{ LPM} = 5920 \text{ CPM, or about } 98 \text{ CPS}$$

$$20 \text{ CPS} \times 150 \text{ LPM} = 3000 \text{ CPM, or about } 50 \text{ CPS}$$

From these calculations, it appears that the impact printer can not operate on a 1200 baud (120 characters per second) communication facility when printing anything less than 132-character print lines. However, because the impact printer used in this terminal is a buffered printer, the difference between the rate of the communication facility and the print rate equals the buffer fill rate. For example,

$$120 \text{ CPS} - 98 \text{ CPS} = 22 \text{ CPS}$$

That is, 22 characters per second is the fill rate of the buffer when the printer is operating on a 1200 baud communication facility and is printing 80-character print lines. At this fill rate, it takes about 46 seconds to fill up the 1024-character print data buffer. When printing 20-character print lines, the fill rate is about 70 characters per second, which translates to about 14 seconds of fill time. These figures, in turn, indicate that the buffered impact printer can operate properly on a 1200 baud communication facility under most normal operation conditions. In fact, under most normal operating conditions of the terminal, it would be unlikely, that the printer would lose any data. An exception to this might occur, however, if full pages of display data were changed rapidly for some reason or another by the central processor.

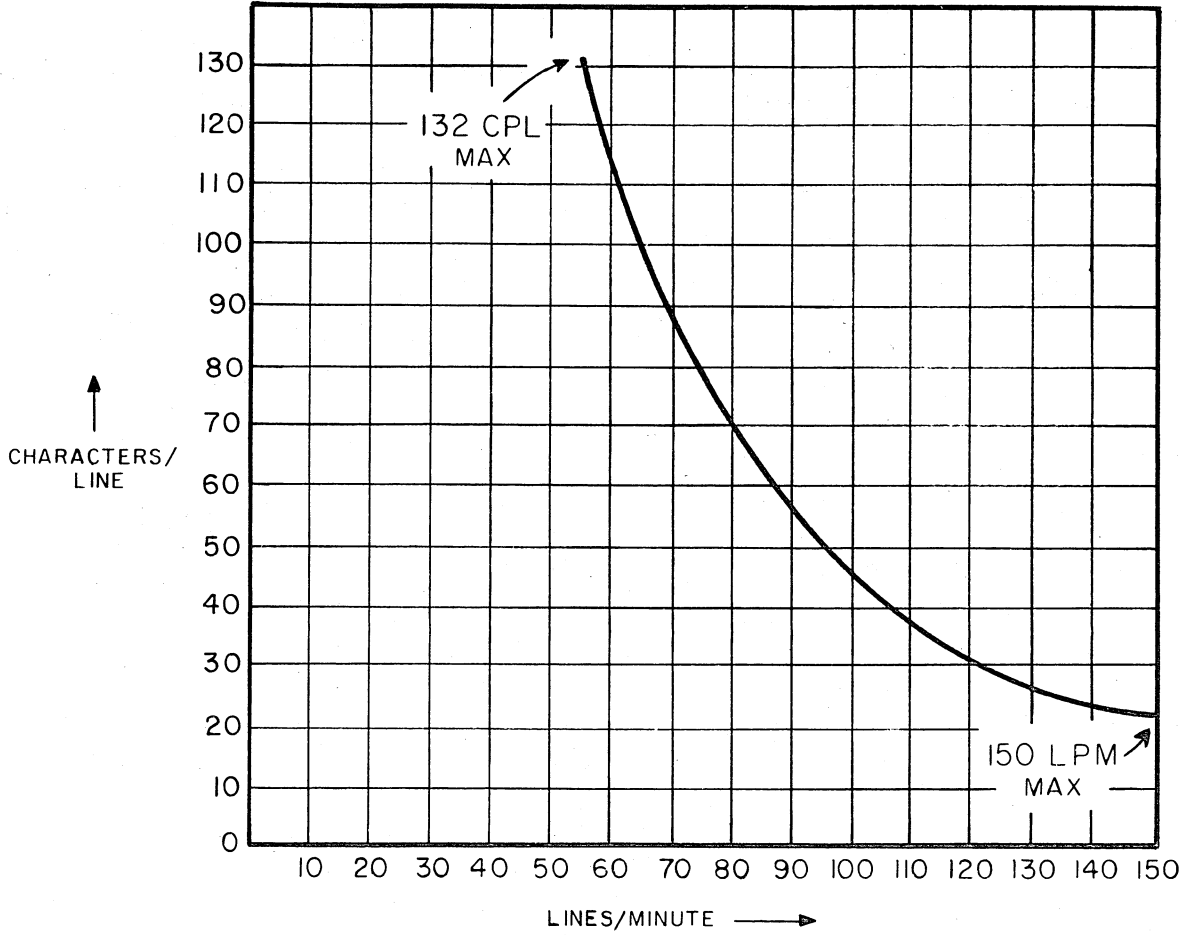

02606

Figure B-1. Impact Printer Print Rates at Varying Print Line Lengths

---

This appendix provides operating, reference, and installation information for the 70-LPM impact printer, to be used with the 752 display terminal. The information contained here parallels in content the 55-LPM impact printer information contained in the existing manual.

This appendix contains the following sections:

- General Description
- Operation
- Codes and Character Sets
- Installation
- Print Rates



# CONTENTS

<u>Section</u>		<u>Page</u>
C1	— GENERAL DESCRIPTION	
	70-LPM Impact Printer Features . . . . .	C1-2
	Print Mechanism . . . . .	C1-2
	Interface and Control Logic Chassis . . . . .	C1-3
	Power Supply . . . . .	C1-3
	Equipment Specifications . . . . .	C1-4
	Physical Characteristics . . . . .	C1-4
	Electrical Data . . . . .	C1-5
	Environmental Specifications . . . . .	C1-5
C2	— OPERATION	
	Controls and Indicators . . . . .	C2-1
	ON/OFF Switch/Indicator . . . . .	C2-1
	START/STOP Switch/Indicator . . . . .	C2-3
	FORM FEED Switch . . . . .	C2-3
	TEST PRINT Switch/Indicator . . . . .	C2-3
	LOAD EVFU Switch . . . . .	C2-3
	6/8 LPI Switch . . . . .	C2-4
	10/16.5 CPI Switch . . . . .	C2-4
	Printer Status/Error Indicators . . . . .	C2-4
	Vertical Forms Positioning Knob . . . . .	C2-5
	Forms Density Control Knob . . . . .	C2-6
	Horizontal Forms Positioning . . . . .	C2-6
	Preparation For Operation . . . . .	C2-6
	Check List . . . . .	C2-6
	Specific Functions . . . . .	C2-7
	Front Cover Removal and Replacement . . . . .	C2-8
	Side Cover Removal and Replacement . . . . .	C2-9
	Upper Cabinet Cover Removal and Replacement . . . . .	C2-9
	Lower Cabinet Skirt Removal and Replacement . . . . .	C2-9
	Forms Installation and Alignment . . . . .	C2-10
	Ribbon Cassette Replacement . . . . .	C2-12
	Format Tape Load Operation . . . . .	C2-14
	Format Tape Punching . . . . .	C2-16
	Paper Basket Operation . . . . .	C2-18
	Printhead Replacement . . . . .	C2-19
	Operator Supplies . . . . .	C2-21
	Forms Recommendations . . . . .	C2-21

<u>Section</u>		<u>Page</u>
	Ribbon Recommendations .....	C2-22
	Format Tape Recommendations .....	C2-22
	Printhead Recommendations .....	C2-23
C3	— CODES AND CHARACTER SETS	C3-1
C4	— INSTALLATION	
	Crating .....	C4-1
	Uncrating .....	C4-1
	70-LPM Impact Printer .....	C4-1
	PC Card Modules .....	C4-3
	Miscellaneous Printer Components .....	C4-3
	Installation .....	C4-4
C5	— PRINT RATES	
	Print Rate Per Line Length .....	C5-1
	Printer 1K Buffer Fill Rate .....	C5-1

## FIGURES

<u>Section</u>	<u>Figure</u>	<u>Page</u>
C1	— GENERAL DESCRIPTION	
	C1-1 70-LPM Impact Printer .....	C1-1
	C1-2 70-LPM Impact Printer Dimensions .....	C1-4
C2	— OPERATION	
	C2-1 Impact Printer Controls and Indicators .....	C2-2
	C2-2 Printer Access .....	C2-8
	C2-3 Forms Path .....	C2-10
	C2-4 Printer Line Finder .....	C2-12
	C2-5 Ribbon Cassette Replacement .....	C2-13
	C2-6 Format Tape Load Operation .....	C2-14
	C2-7 Format Tape Configuration .....	C2-16
	C2-8 Format Tape Punch .....	C2-17
	C2-9 Paper Basket Operation .....	C2-19
	C2-10 Printhead Replacement .....	C2-20

<u>Section</u>	<u>Figure</u>	<u>Page</u>
C4	— INSTALLATION	
	C4-1 Crating and Uncrating the 70-LPM Impact Printer . . . . .	C4-2
	C4-2 Printer Dimensions . . . . .	C4-4
	C4-3 Alternate Power Configuration for Wiring the Universal Transformer . . . . .	C4-6
	C4-4 Location and Functions of SWN4 Switches . . . .	C4-7
	C4-5 70-LPM Impact Printer Internal Switches and Jumpers . . . . .	C4-8
C5	— PRINT RATES	
	C5-1 70-LPM Impact Printer Print Rates at Varying Line Lengths . . . . .	C5-2

## TABLES

<u>Section</u>	<u>Table</u>	<u>Page</u>
C2	— OPERATION	
	C2-1 Printer Status/Error Indicator Codes	C2-5



## GENERAL DESCRIPTION

C1

This section describes features and equipment specifications of the 70-LPM impact printer.

The 70-LPM printer (figure C1-1) is a single head bidirectional printer. It has a print rate of 70 lines per minute (50/60 Hz) and prints a full line of 132 (7- by 9-dot pattern) characters, with a maximum short line print rate of 200 lines per minute. The standard character pitch is 10 characters per inch, with an operator selectable compressed pitch of 16.5 characters per inch. The printer has position seeking capability for increased speed throughout.

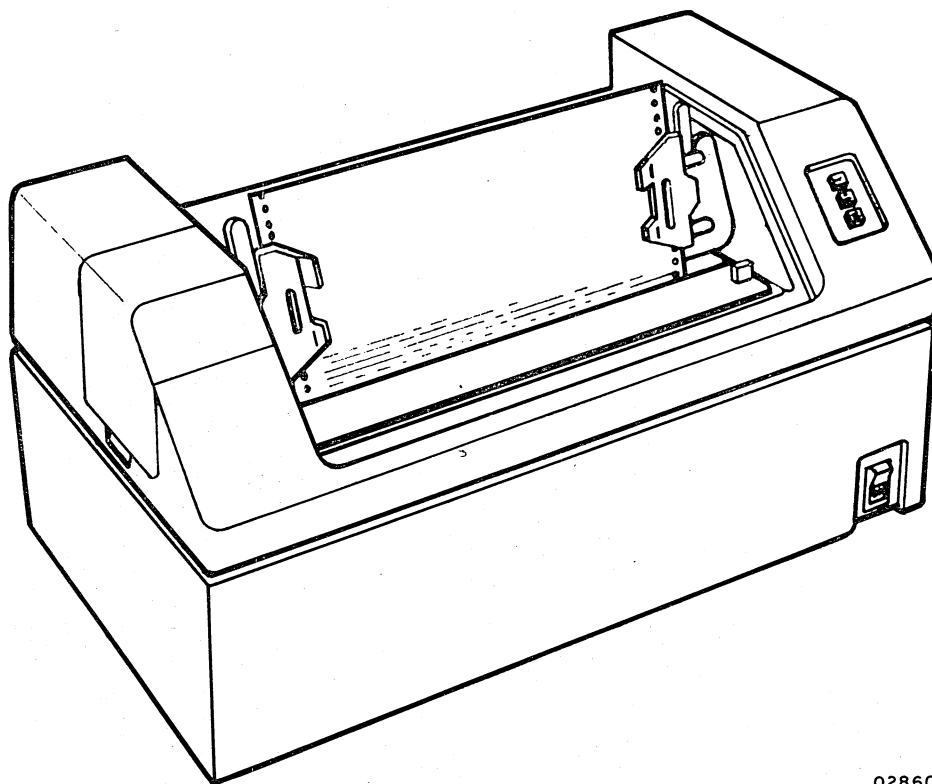

02860

Figure C1-1. 70-LPM Impact Printer

## 70-LPM IMPACT PRINTER FEATURES

The following are basic features of the 70-LPM printer:

- Uses a 7- by 9-dot matrix with lowercase descenders to form characters.
- Prints up to 154 characters per second.
- Electronic vertical format unit (EVFU) — reads a punched format tape and loads it into controller memory, where it is combined with coded disk pulses to determine the line spacing.
- LED diagnostics — the controller electronics isolate and display on six LED lamps a binary code for a controller detectable error condition.
- An output paper basket.
- Receives data at rates of 150, 300, 600, 1200, 1800, or 2400 baud.
- Operator selection of compressed or normal character pitch — printing occurs in the normal 10-character-per-inch horizontal pitch or in a compressed 16.5-character-per-inch pitch. Character pitch selection also interacts with the full printline length feature.
- Selectable full printline length — an internal switch limits full printline length either to 8 in (20.32 cm) or 13.2 in (33.53 cm). This selection, together with that of character pitch, governs the capacity variance; operation of line buffer remains the same.
- Operator selection of vertical line spacing at either 6 lines per inch or 8 lines per inch.
- A group of operator-accessible Printer Status/Error indicators.

### PRINT MECHANISM

The following are features of the print mechanism.

- Prints bidirectionally — the printhead alternately prints a line in one direction and the following line in the opposite direction, with the printhead moving just far enough to accomplish printing.
- An operator-replaceable printhead.
- Because of automatic printhead movement, printer motion control code CR (carriage return) only ends printline character accumulation in the line buffer and does not effect printhead movement after the characters are printed.

## **INTERFACE AND CONTROL LOGIC CHASSIS**

A printer online operation is initiated when the Data Set raises the Data Set Ready line and the Received Line Signal Detect line and starts transmitting bit serial data on the Received Data line. The printer uses a UART logic chip to assemble the bit serial data into parallel words. After assembly, the character is stored in the adapter memory located on the RS-232-C interface board. The adapter memory acts as a buffer between the interface and the printer. The interface writes into it, and the printer reads out of it. Read operations are performed between write operations. During read, the character stored in the adapter memory is transferred to the printer memory. After transfer to the printer memory, operation of the buffered printer is identical to the unbuffered printer.

There are eight interface lines plus a logic ground and a protective ground between the modem and the printer. The eight interface lines are Received Data, Request To Send, Data Set Ready, Data Terminal Ready, Received Line Signal Detector, Reverse Channel, Secondary Request To Send, and Ring Indicator.

The logic chassis is located at the rear of the printer and houses all the printed circuit boards with the exception of the needle driver board assembly, vertical transducer board assembly, horizontal transducer board assembly, and control panel board assembly.

All the boards in the logic chassis are hinged at the bottom and swing down for easy access.

## **POWER SUPPLY**

The input voltage to the transformer is stepped down to four ac output voltages. The four voltage outputs are: +30 V ac, +55 V ac, and two separate +16 V ac. The four ac output voltages then enter the power supply board where they are converted into dc voltages. The dc distribution is initiated on the power supply board.

The power supply develops six dc voltages: +36 V dc, -36 V dc, +5 V dc, -5 V dc, +12 V dc, and -12 V dc. The +36 V dc and the -36 V dc are used to supply power to the vertical (paper motion) and horizontal (printhead transport) servo linear power amplifiers, which in turn supplies power to the drivehead transport and paper motion servo motors; +36 V dc also provides power to the needle driver coils.

The +12 V dc and -12 V dc are used to power the servo linear control circuits. The +5 V dc and -5 V dc are used to power the controller circuits. The +5 V dc also supplies power to the servo digital control circuits.

## EQUIPMENT SPECIFICATIONS

The following paragraphs describe the physical characteristics, electrical data, and environmental specifications for the 70-LPM printer.

### PHYSICAL CHARACTERISTICS

The 70-LPM printer (figure C1-2) has the following dimensions and weight.

Height: 13.5 in (34.29 cm)

Width: 28.75 in (73.03 cm)

Depth: 17.3 in (43.94 cm)

Weight: 98 lb (44.5 kg)

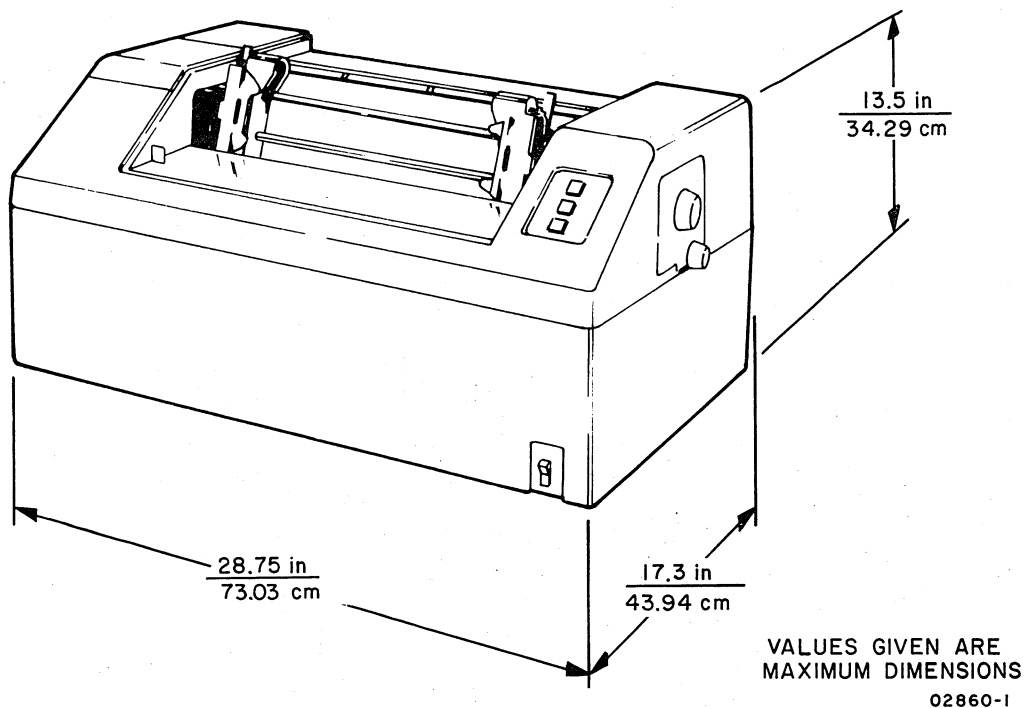

Figure C1-2. 70-LPM Impact Printer Dimensions

## ELECTRICAL DATA

The 70-LPM printer has the following electrical power requirements.

59 to 60.6 Hz, single-phase, 2.8 A

49 to 50.5 Hz, single-phase, 1.5 A

with tap selectable ranges:

<u>Nominal V ac</u>	<u>Voltage Range (V ac)</u>
100	90 to 107
120	104 to 127
200	180 to 213
220	198 to 235
230	207 to 246
240	216 to 257
260	234 to 278

Power use of the printer is 243 watts operating and heat dissipation is 829 Btu/h.

## ENVIRONMENTAL SPECIFICATIONS

The environmental specifications for the 70-LPM printer are the same as the environmental specifications described in the General Description section of the existing manual.

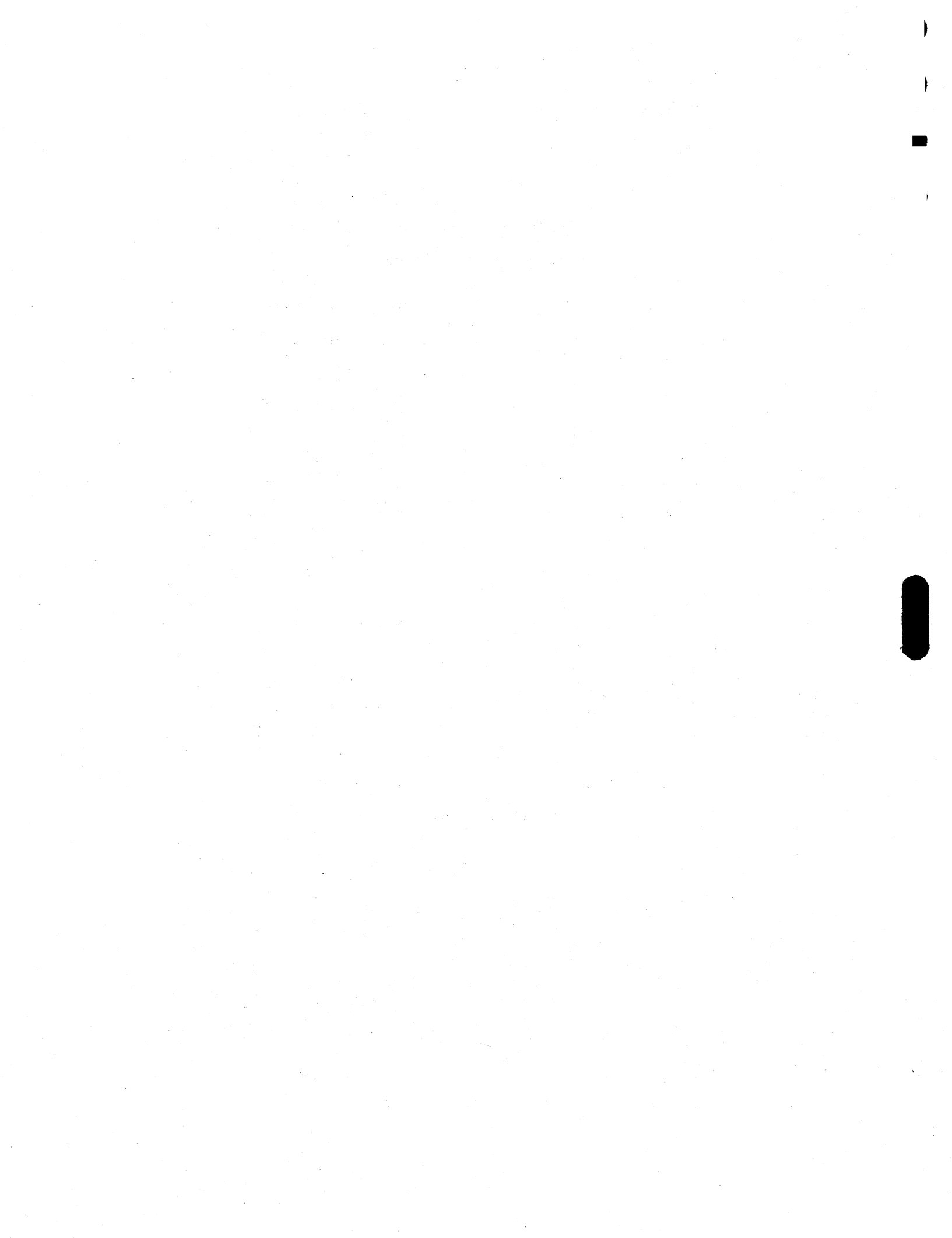

---

This section describes the controls and indicators, preparation for operation, and operator supplies. The controls and indicators portion of this section describes the locations and functions of the controls and indicators. The preparation for operation portion describes how to prepare the 70-LPM impact printer for operation. The operator supplies portion includes information regarding the supplies required (such as printer forms, ribbon cassette, etc.).

## CONTROL AND INDICATORS

The locations of the operator controls and indicators on the 70-LPM printer are shown in figure C2-1. The switches and indicators are the ON/OFF switch/indicator, the START/STOP switch/indicator, the FORM FEED switch, the TEST PRINT switch/indicator, the LOAD EVFU switch, the 6/8 LPI switch, the 10/16.5 CPI switch, and six Printer Status/Error indicators. Other controls include the Vertical Forms Positioning knob, the Forms Density Control knob, and the horizontal forms positioning of the tractors.

### NOTE

The internal printer controls are not included in the following coverage of controls and indicators because they are not operator accessible. The installation procedure for setting these controls is discussed in the Installation section of this appendix.

### ON/OFF SWITCH/INDICATOR

The ON/OFF switch/indicator, located at the lower-right front of the printer, is used to apply or remove power to the printer. The switch/indicator is illuminated at all times that power is turned on. When the printer is initially turned on, the switch causes a master clear operation that clears all the logic circuitry in preparation of operation. If the switch is actuated a second time, the printer is turned off.

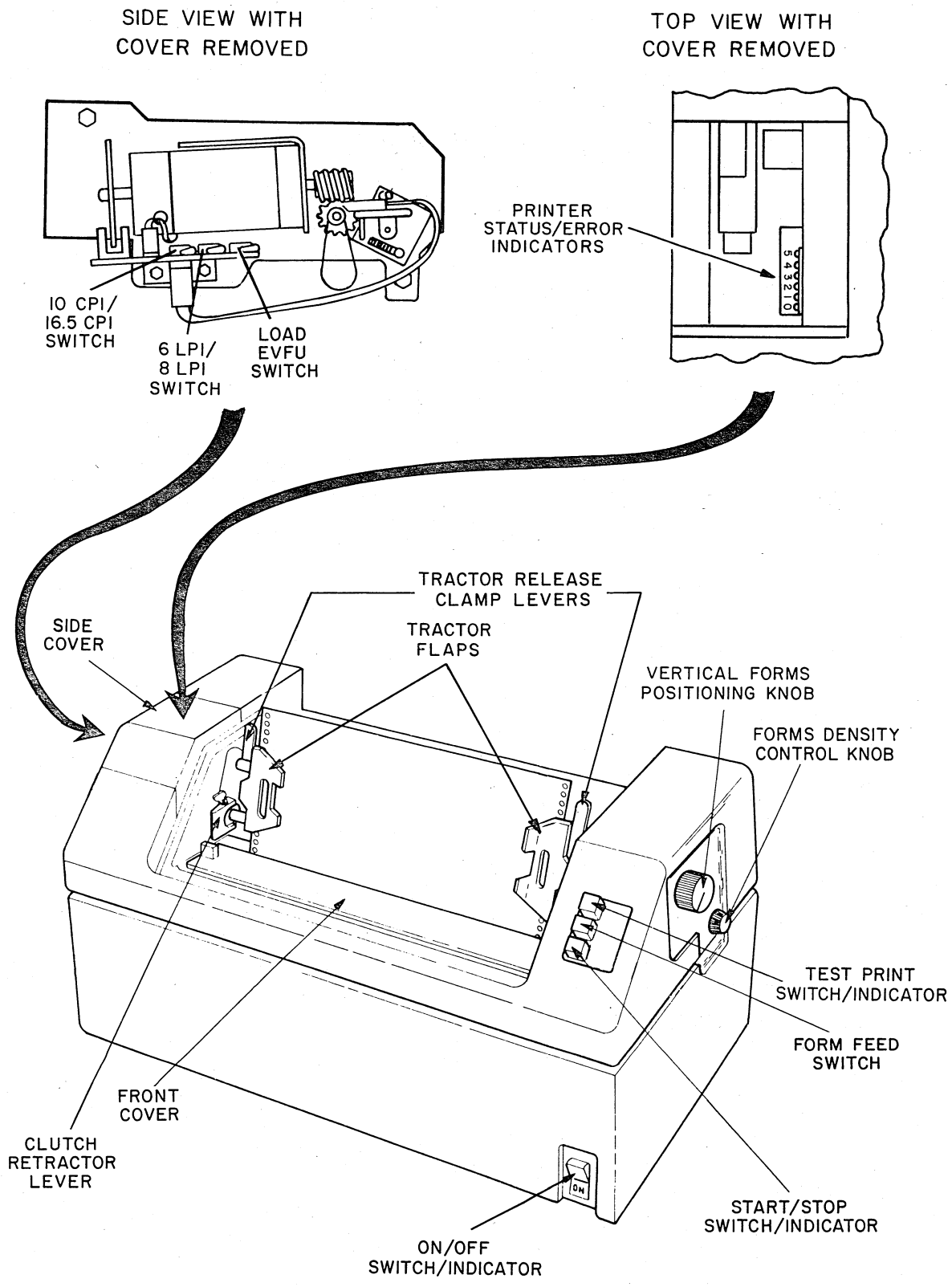

Figure C2-1. Impact Printer Controls and Indicators

02855

## **START/STOP SWITCH/INDICATOR**

The START/STOP switch/indicator, located at the top-right front of the printer, enables or disables printing. The switch/indicator is illuminated whenever printing is enabled (printer in start condition). It remains illuminated until the switch is actuated a second time to disable printing (printer in stop condition). If printing is in process, the transition from start to stop is delayed until printing is complete. Also, if the front cover is not seated properly, an interlock switch prevents placing the printer in the start condition.

## **FORM FEED SWITCH**

This momentary action switch, located at the top-right front of the printer, advances the paper to the next top of form per channel 1 punching of format tape. The FORM FEED switch is only operable when the printer is in a stop condition.

## **TEST PRINT SWITCH/INDICATOR**

When the printer is in a stop condition, pressing this switch/indicator causes the printer to print the character B alternating with blanks across the page and then to perform a single line advance. The resulting pattern may be used to check vertical and horizontal alignment of forms prior to placing the printer in start. The switch/indicator is illuminated while the test print operation is in process and remains illuminated until the switch is pressed a second time to halt the operation.

## **LOAD EVFU SWITCH**

The LOAD EVFU (electronic vertical format unit) switch, located on the left side of the printer, is accessible by lifting-off the side cover. Toggling the momentary LOAD EVFU switch causes the electronic vertical format unit to read the format tape and load the tape punching into memory. When loading is complete, the format tape automatically stops and the tape is removed from the unit. This format tape punching tells the printer what the paper motion distances will be for top of form (form feed), and vertical tab in print operations. Format tape reloading is required whenever:

- Power has been removed from the printer.
- A change in paper form length (fold to fold) is made. This would involve loading a new format tape with different channel 1 and channel 2 punchings that correspond to the top of form and vertical tab positions of the new size forms.
- A reselection of vertical spacing is made via the 6/8 LPI switch.

## 6/8 LPI SWITCH

The 6/8-LPI (lines per inch) toggle switch, accessible via the side cover, selects vertical line spacing of either 6 lines per inch or 8 lines per inch. Anytime the setting of this switch is changed, the format tape must be reloaded.

## 10/16.5 CPI SWITCH

The 10/16.5-CPI (characters per inch) toggle switch, accessible via the side cover, selects a horizontal character pitch of either 10 characters per inch or 16.5 characters per inch. This selection, together with the full printline length selected during installation, determines what the line buffer capacity is during printing; and thus what number of characters is printed in a full printline:

<u>Full Printline Length</u>	<u>Character Pitch</u>	<u>Line Buffer Capacity</u>
13.2 in	10 CPI	132 characters*
8 in	10 CPI	80 characters*
13.2 in	16.5 CPI	217 characters*
8 in	16.5 CPI	132 characters*

## PRINTER STATUS/ERROR INDICATORS

The six Printer Status/Error indicators, located under the side cover, display a code that shows:

- If the printer is inoperable and requires maintenance personnel attention.
- When format tape loading is unsuccessful, the cause.
- When neither of the preceding conditions have occurred, the current operating status of the printer.

Table C2-1 defines all the codes that the indicators may display.

---

\* Plus one printer motion control code (CR, LF, VT, FF).

TABLE C2-1. PRINTER STATUS/ERROR INDICATOR CODES

CODE DISPLAYED BY INDICATORS*						SIGNIFICANCE
5	4	3	2	1	0	
0	0	0	0	0	1	Printer requires maintenance personnel attention
0	0	0	0	1	0	Printer requires maintenance personnel attention
0	0	0	0	1	1	START/STOP switch not released
0	0	0	1	0	0	Printer waiting for switch actuation (if an attempt to actuate the START/STOP switch has been made, this means the front cover interlock switch is open)
0	0	0	1	0	1	The format tape loaded is missing channel 1 punchings
0	0	0	1	1	0	The format tape loaded is punched incorrectly
0	0	0	1	1	1	LOAD EVFU switch not released
0	0	1	0	0	0	The format tape loaded is too long (more than 176 lines)
0	0	1	0	0	1	Printer requires maintenance personnel attention
0	0	1	0	1	1	Printer waiting to load data into line buffer
0	0	1	1	0	0	Printer is loading data into line buffer, but printline accumulation is not complete
0	0	1	1	1	0	FORM FEED switch not released
0	0	1	1	1	1	TEST PRINT switch not released
0	1	0	1	0	0	} Printer requires maintenance personnel attention
0	1	0	1	0	1	
0	1	0	1	1	0	
0	1	0	1	1	1	
0	1	1	1	0	0	
0	1	1	1	0	1	
0	1	1	1	1	0	
0	1	1	1	1	1	

\* Key:  
 1 = indicator lit  
 0 = indicator not lit

02888

**VERTICAL FORMS POSITIONING KNOB**

The Vertical Forms Positioning knob, located on the right side of the printer, manually moves the forms when vertical positioning and alignment is required. In order to do this, the Clutch Retractor lever must be pressed while turning the knob. When pressed, the Clutch Retractor lever decouples the tractor shaft from the forms advance mechanism allowing the forms to be moved manually.

## **FORMS DENSITY CONTROL KNOB**

This smaller knob on the right side of the printer is turned to compensate for different thicknesses of forms. As the Forms Density Control knob is turned clockwise, the gap between the print mechanism and the print surface is increased, allowing accommodation of heavy-weight or multiple-part forms. The opposite is true when the knob is turned counterclockwise. The knob has five detented positions it can be placed in. These five positions do not correspond to the number of copies being handled, but are provided for operator reference when forms are changed frequently.

## **HORIZONTAL FORMS POSITIONING**

Horizontal forms positioning is accomplished by manually positioning the two tractors so that their pins engage with the feed holes of the paper. A tractor is slid horizontally by releasing its clamp lever while applying pressure to its side.

## **PREPARATION FOR OPERATION**

This portion describes the procedures used in preparing the 70-LPM printer. The procedures include both general check items and specific operator functions (loading forms, etc.).

### **CHECK LIST**

Included in the check items for the 70-LPM printer are checks of the printer forms (paper) supply and print quality. The following are initial preparation checks for the 70-LPM printer.

- 1) Ensure printer ON/OFF switch is in the OFF position. Plug printer into its power outlet.
- 2) Install ribbon cassette to printhead (if not done already, refer to Ribbon Cassette Replacement procedure).
- 3) Install forms and lower necessary paper weights (refer to Forms Installation and Alignment procedure).
- 4) Power on the printer. To operate printer with cabinet removed, the interlock switch, left of the control panel, is pulled up.

## CAUTION

If diagnostic routines are performed that require continuous column printing, the duration should be limited to 5 minutes (maximum) or damage will result to the solenoid assemblies.

- 5) Actuate TEST PRINT switch located on the controller and printhead board. This switch causes the printer to print the character B, alternating with blanks across the page and then performs a single line advance. Use this pattern to check vertical and horizontal alignment of the forms.
- 6) Actuate TEST PRINT switch. A second actuation terminates the test print operation.
- 7) Check out the 6/8 LPI switch setting and the 10/16.5 CPI switch setting. Do not actuate the 6/8 LPI switch or the 10/16.5 CPI switch when the printer is printing in the test print mode. Terminate test print operation, actuate 10/16.5 CPI switch and reenter the test print mode.
- 8) Load format tape into reader (refer to Format Tape Load Operation procedure). Actuate LOAD EVFU switch and load format tape into memory. Press FORM FEED switch on the control panel. The printer should slew paper to the top of the form.
- 9) Power off the printer by placing ON/OFF switch in the OFF position. Remove forms from printer.
- 10) Replace lower cabinet skirt and all covers (refer to specific removal and replacement procedure).
- 11) Power on the printer.
- 12) Load forms.
- 13) Reload format tape into memory.
- 14) Install interface cable and actuate the START/STOP switch. The switch illuminates and the printer is ready for online operation.

## **SPECIFIC FUNCTIONS**

The following paragraphs include removal and replacement procedures for the 70-LPM printer: 1) front cover, 2) side cover, 3) upper cabinet cover, and 4) lower cabinet skirt (figure C2-2).

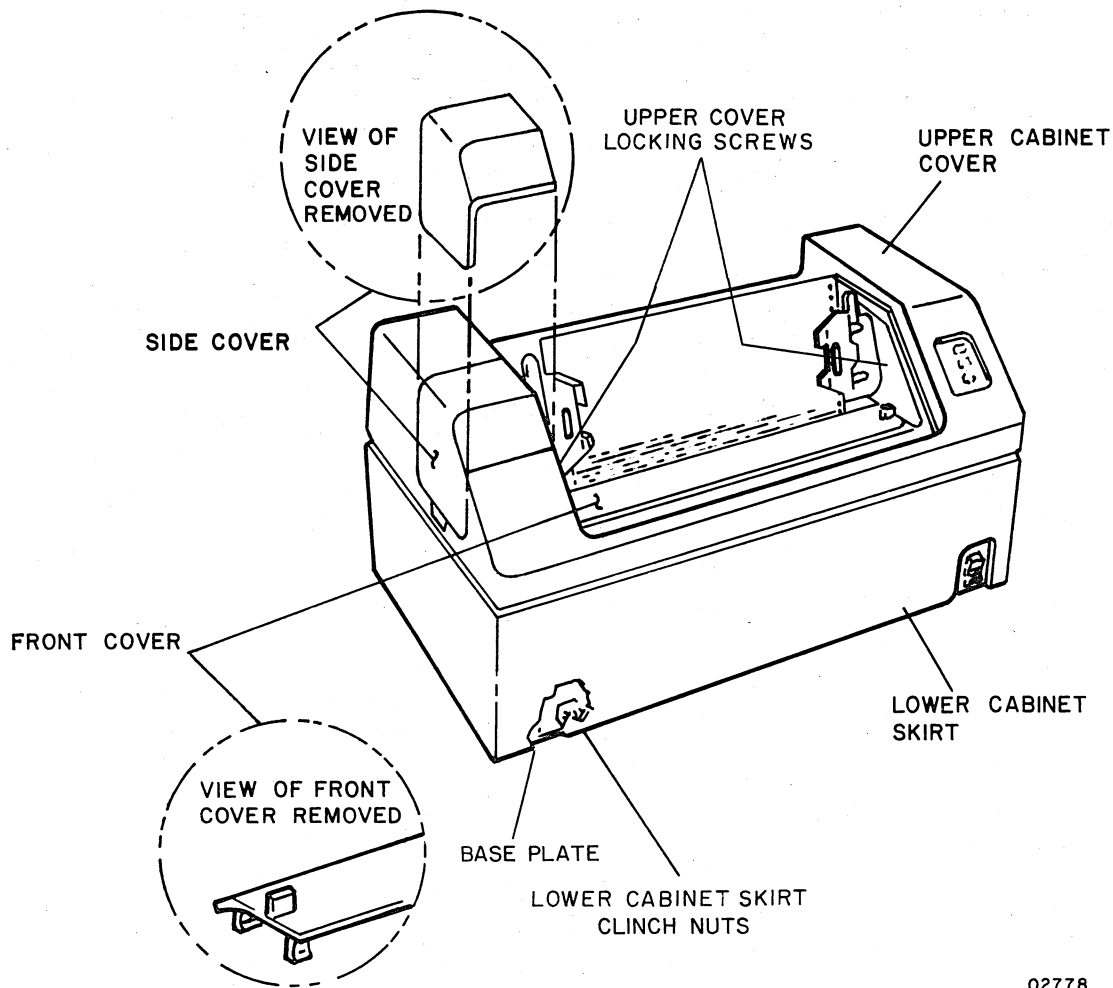

02778

Figure C2-2. Printer Access

Also included are procedures describing the operator functions for: 1) forms installation and alignment, 2) ribbon cassette replacement, 3) format tape load operation, 4) format tape punching, 5) paper basket operation, and 6) printhead replacement. Forms, ribbon, format tape, and printhead requirement are included at the end of this section.

### Front Cover Removal and Replacement

Removal of the front cover permits access for changing ribbon cassettes and forms loading. To remove the front cover, grasp the two lifting tabs on either side of the cover and lift the cover up and off the upper cabinet.

When replacing the front cover, the beveled edge must be toward the rear of the machine facing down. Care should be taken that the four corner guides are engaged properly into the upper cabinet before seating the front cover.

#### NOTE

There is an interlock under the right front cover tab which will not function if cover is not seated properly.

### **Side Cover Removal and Replacement**

Removal of the side cover permits access to the format reader, format tape, 6/8 LPI switch, 10/16.5 CPI switch, the LOAD EVFU switch, and the Printer Status/Error indicators. To remove the side cover, place your finger tips in the depression in the left side of the upper cabinet and under the bottom edge of the side cover and lift it up and off the upper cabinet.

### **Upper Cabinet Cover Removal and Replacement**

Removal of the upper cabinet cover permits access to the control panel wiring, format reader, paper drive servo motor, and access for removal of the printhead. To remove cover, turn the two locking screws (figure C2-2) in until they clear the plastic cover and bottom out against the right and left format plates. Remove the Vertical Forms Positioning knob on the right side of cover by pulling it off of its shaft and lift cabinet cover off the lower cabinet skirt.

To install, back locking screws out to the lock nut stop.

### **Lower Cabinet Skirt Removal and Replacement**

#### WARNING

Interior of cabinet has hazardous voltage. Exercise extreme caution if power is left on or turn power off and disconnect ac power cord from site outlet.

Removal of the lower cabinet skirt permits full access to all inner printer areas and must be removed to access or probe most of the printed circuit cards.

The lower cabinet skirt may not be removed without first removing the upper cabinet cover.

The lower cabinet skirt is fastened to clinch nuts in the base plate with four slotted head screws. Loosening of these four screws permits the lower cabinet skirt to be lifted up and off the base plate.

#### NOTE

Screws are not captive any may fall out if skirt is tipped or turned over.

### Forms Installation and Alignment

The following procedure is designed to aid the operator in correctly installing and aligning the fanfold forms for the 70-LPM printer (figure C2-3):

- 1) Turn printer off or place it in stop mode. Remove front access cover (refer to Front Cover Removal and Replacement procedure).
- 2) Place stack of fanfold forms behind the printer, directly below forms input slot.

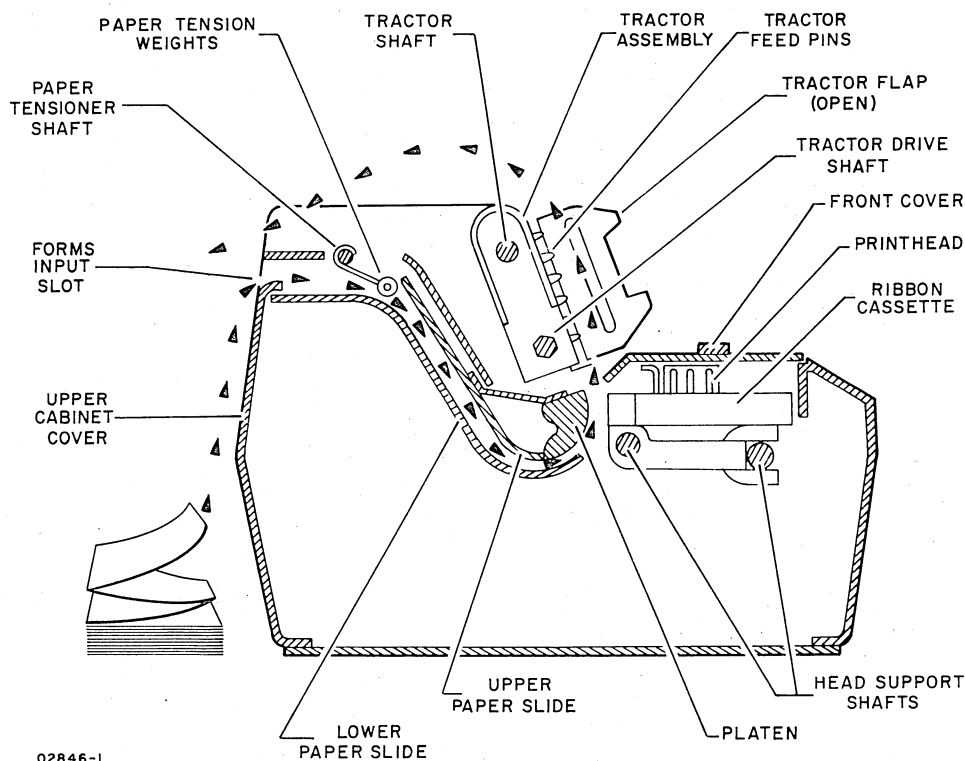

Figure C2-3. Forms Path

- 3) Insert top form in the rear forms slot and under paper tension weights. The four paper tension weights may be raised and locked in an up position during form loading. Continue feeding the forms between the upper and lower paper slides until the form is visible at the platen in the front of the printer. When loading multiple-part forms, it may be necessary to increase the gap between the printhead face and the platen so the form may pass with ease. This is accomplished by turning the Forms Density Control knob clockwise.
- 4) Grasp form and pull it up until the top of the form is in line with the top of the tractor flaps.
- 5) Open left tractor flap and position forms on tractor feed pins. Close flap.
- 6) Replace front access cover and use column guide for forms position reference.
- 7) Release left tractor clamp lever and position left tractor flap for desired margin on the form. Reclamp tractor flap in place with the tractor clamp lever.
- 8) Open the right tractor flap and release its tractor clamp lever. Position right tractor flap so that tractor feed pins can be seen through the form feed holes.
- 9) Position form on tractor feed pins. Close left tractor flap.
- 10) Slide right tractor flap to the right side very slightly until form is taut. Reclamp right tractor flap in place with the tractor clamp lever.
- 11) Using the Vertical Forms Positioning knob, position top edge of the first form at top edge of the tractor flaps. If top edge of the form does not line up with top of both tractor flaps, the form is misaligned on the feed pins.

#### NOTE

Whenever the printer is switched off, the format tape is lost from memory. With each new initiation of operation, the format tape must be loaded into memory (refer to Format Tape Load Operation procedure).

- 12) Load the format tape.
- 13) Turn printer on.

- 14) Actuate FORM FEED switch. The format reader memory is now at the top of forms position.
- 15) Press Clutch Retractor lever and use Vertical Forms Positioning knob to align the first line of print position on the forms to the print position on the line finder (figure C2-4). Release Clutch Retractor lever.
- 16) Reset Forms Density Control knob if it was moved during form loading. Lower necessary paper tension weights. The forms should now be ready for printing. For single-part forms, use only the two center weights. Swing the outer two weights up away from the forms. For multiple-part forms, all four weights are normally used. For narrow forms, any weight not covering the form with at least half of its width should be lifted. If forms tear at the sprocket holes, weights should be lifted until the tearing is eliminated. If tearing continues, the Forms Density Control knob needs adjusting.

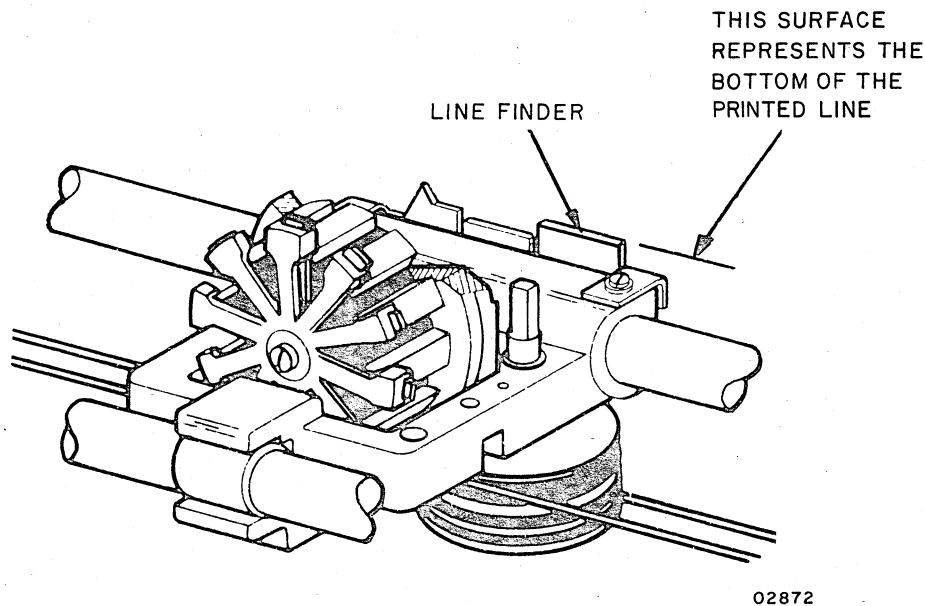

Figure C2-4. Printer Line Finder

### Ribbon Cassette Replacement

The ribbon used in the 70-LPM printer consists of a disposable ribbon cassette that snaps over the printhead and engages a cassette drive shaft on the printhead support assembly. Each ribbon cassette contains an endless loop of nylon ribbon that is cycled through the cassette in one direction until the end of ribbon life is reached (refer to Operator Supplies for ribbon cassette replacement recommendation).

The following procedure should be followed when replacing cassettes:

- 1) Remove front cover to gain access to ribbon cassette (refer to Front Cover Removal and Replacement procedure).
- 2) Place your finger tips under cassette locking tab and pull it up until you hear a slight click, indicating that the cassette has disengaged from the head support and pulley assembly (figure C2-5).

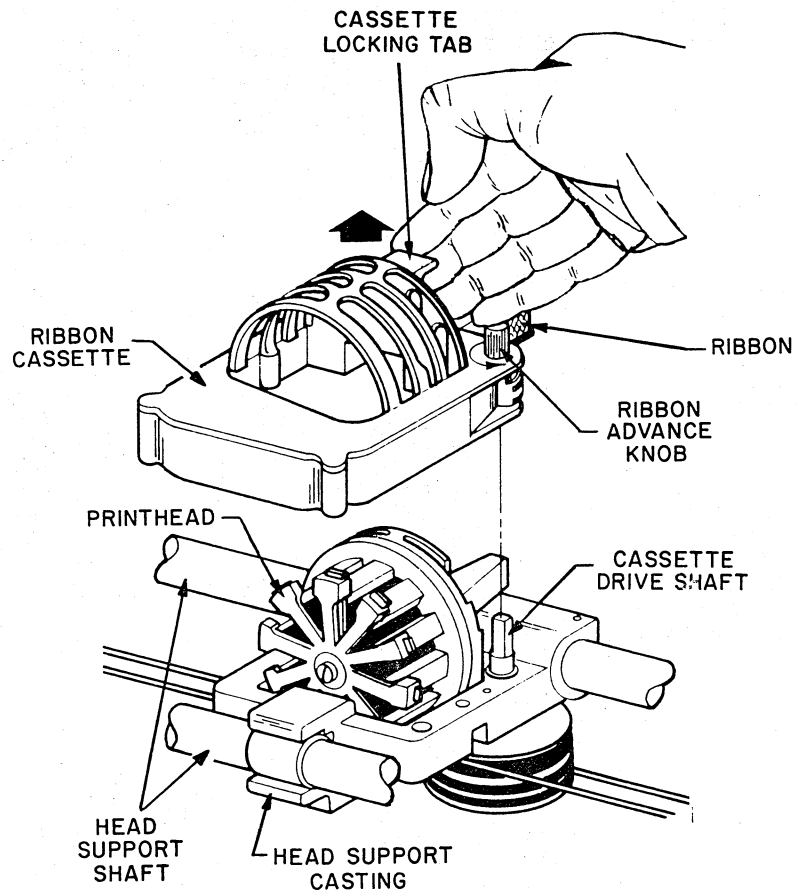

02871

Figure C2-5. Ribbon Cassette Replacement

- 3) Remove ribbon cassette by lifting it up and off of the printhead.
- 4) Remove new ribbon cassette from its wrappings and ensure that the cassette locking tab is in the up (disengaged) position.
- 5) Place new ribbon cassette over the printhead so that the drive spline on the bottom of the cassette engages the cassette drive shaft on the head support. The Ribbon Advance knob on the top of the cassette may be turned counterclockwise slightly to aid the engagement of the spline and drive shaft.

- 6) While applying a slight pressure to the top of the cassette with one hand, press cassette locking tab down until you hear a click. The cassette should now be locked to the head support and pulley assembly. Ensure ribbon is set in front of print pens or wires.
- 7) Using thumb and forefinger of one hand, grasp cassette by both sides and lift up using a moderate pressure. If cassette lifts off the printhead, it was not seated properly and steps 4 through 7 should be repeated.
- 8) Replace front cover and ensure that it is seated properly.

#### NOTE

A safety interlock switch disables mechanical motion when the front cover is removed or not seated properly.

### Format Tape Load Operation

The following procedure describes format tape loading for 70-LPM printer.

- 1) Power on the printer. Remove side cover (refer to Side Cover Removal and Replacement procedure) to gain access to the electronic vertical format unit and its load switch (figure C2-6).

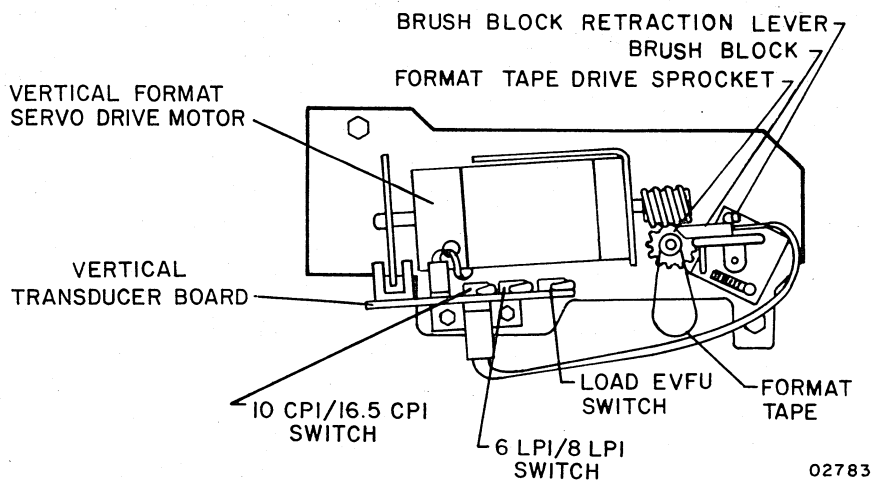

Figure C2-6. Format Tape Load Operation

- 2) Lift the brush block away from the format tape drive sprocket by pulling the Brush Block Retraction lever to the front of the printer.
- 3) Mount the format tape over the teeth on the format drive sprocket. Lower the brush block to hold the format tape in place. This is accomplished by pushing the Brush Block Retraction lever to the rear of the printer.
- 4) Check the 6/8 LPI switch and the 10/16.5 CPI switch to see that these are switched to the required modes. Also check to see that the proper 6/8-line-per-inch format tape is being loaded. The selector switches for 6/8 lines per inch and for 10/16.5 characters per inch are located on the vertical transducer board assembly.
- 5) The electronic vertical format unit (EVFU) consists of a format brush reader and a LOAD EVFU switch. The primary function of the EVFU is to read a punched format tape and load it in controller memory so that it can determine vertical line spacing.

Load the format tape into the format tape memory by activating the LOAD EVFU switch which is located on the vertical transducer board assembly. This momentary action switch returns to its original position after being actuated.

Activation of the switch causes the tape to pass through the reader until two successive form feeds are sensed, then the tape is automatically reread to check the loaded data. The tape stops when a successive load and check has occurred.

#### NOTE

The brush block must be raised first. Also the tape does not have to be removed from the sprocket wheel.

Remove the tape and raise the brush block assembly so that the brushes are not contacting the sprocket wheel. The maximum format tape length that may be loaded is 176 lines.

The tape must be reloaded whenever the 6/8-lines-per-inch mode is changed or the printer is turned off.

A minimum of 2 full pages of forms moves through the tractors during format tape loading operation.

## Format Tape Punching

The following describes the method used in punching format tapes for the 70-LPM printer. A list of recommended supplies for format tape, format tape punch, and format tape splices is included under the heading Operator Supplies at the end of this section.

This tape is longitudinally divided into channels that are punched with holes to provide fixed format control signals for the printer mechanism. Since the printers only respond to line-feed, vertical-tabulation, and form-feed format control codes, only three channels of the format tape need to be used. Channel 1 is the form feed, or top of forms, channel; channel 2 is the vertical tabulation channel; and channel 3 is the line feed channel. Format tapes for the printer do not have channel 3 punched because the 70-LPM printer uses an automatic line-feed control circuit (either 6- or 8-line-per-inch mode). Figure C2-7 shows the characteristics of a format tape and figure C2-8 illustrates the type of punch used in punching the format tape.

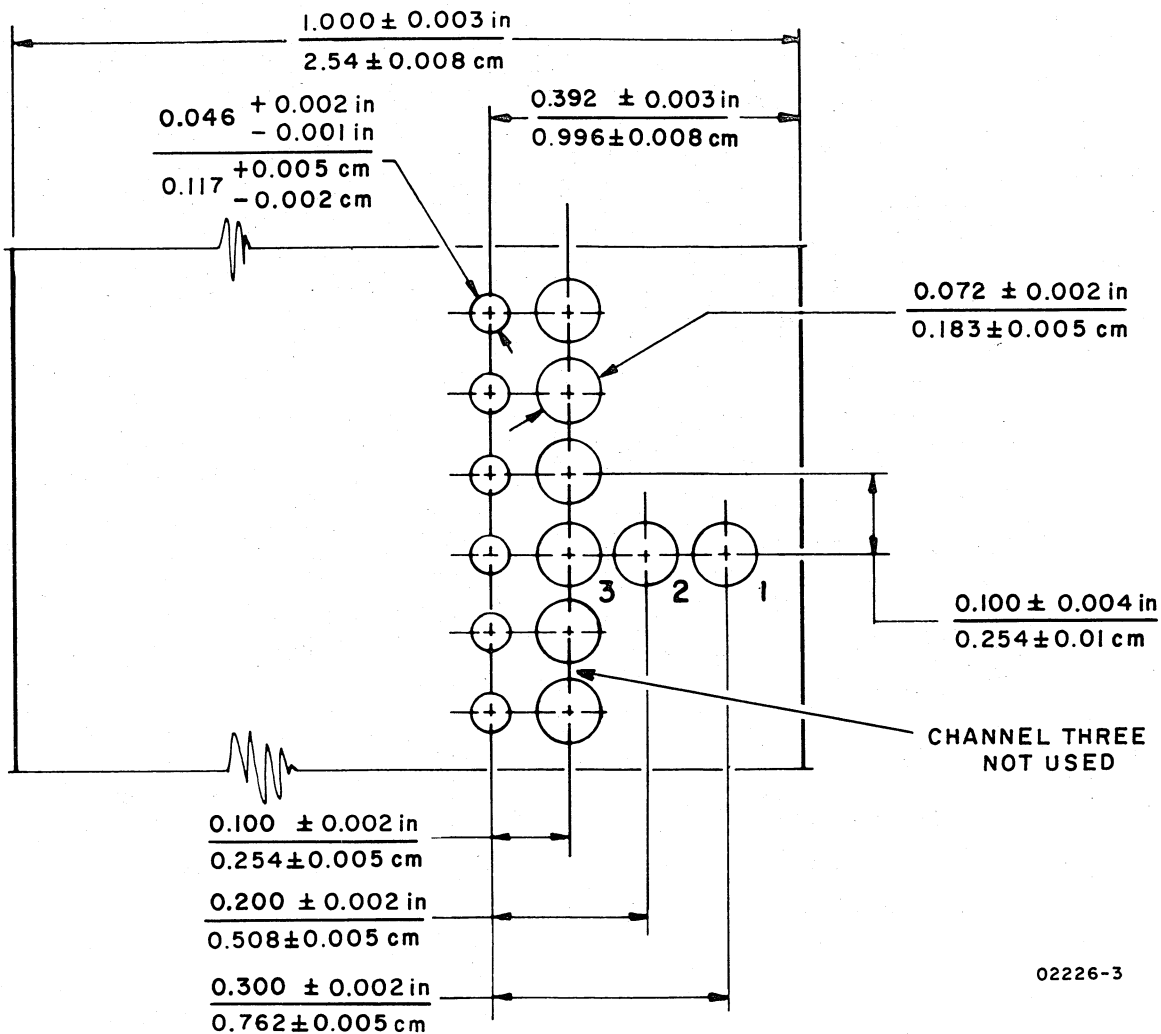

Figure C2-7. Format Tape Configuration

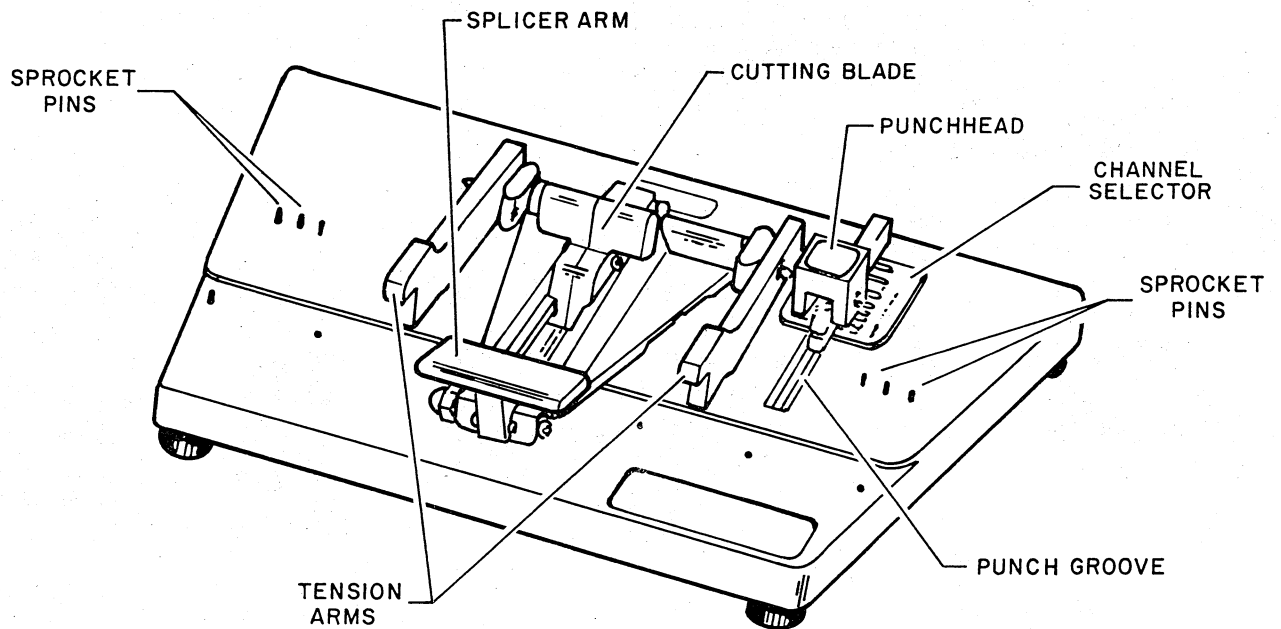

Figure C2-8. Format Tape Punch

02782-1

The format tape punching procedure is as follows:

- 1) Raise splicer arm of punch up and swing it back out of the way during the punching operation.
- 2) Slide punchhead and channel selector mechanism to the rear of the punch.
- 3) Raise tension arms and place format tape facedown on punch so that sprocket drive holes in tape pass over sprocket pins on punch. Lower tension arms to hold format tape in position on punch.
- 4) Slide punchhead and channel selector mechanism to the channel 1 position for punching the top-of-forms (form feed) hole, and press the punchhead down to punch the hole in the tape.
- 5) If a vertical tabulation hole is also desired at the top-of-forms position, slide punchhead and channel selector mechanism to the channel 2 position and press punchhead to punch the vertical tabulation hole.
- 6) If other vertical tabulation holes are to be punched in the tape, lift tension arms and remove the format tape from the punch.
  - a) Determine where tab position is on form relative to top-of-form position. This measurement is either in inches, 2 in (5.08 cm) on form equals 1 in (2.54 cm) on tape, or in printlines, one printline on form equals one drive sprocket hole on tape.
  - b) Measure from top-of-forms hole position on tape, or count drive sprocket holes, to the next desired vertical tab hole on the tape and mark this latter location with a pencil.

- c) Place format tape in punch so that desired vertical tab point (pencil mark) is aligned with punchhead (refer to step 3 for positioning tape in punch).
  - d) Ensure that punchhead and channel selector are positioned for a channel 2 punch and press the punchhead to punch the desired vertical tab hole. This step may be repeated for as many vertical tab positions required.
- 7) When desired length of tape is reached, align end line of tape with the groove below splicer arm area of punch. Lower splicer arm down on the tape and draw cutting blade forward across tape.
  - 8) To splice the tape, raise the splicer arm and place the two ends of the format tape over the punch sprocket pins so that the ends abut at the groove beneath the splicer area of the punch.
  - 9) Remove adhesive backing from a format tape splice and position splice on sprocket pins so that it equally covers both ends of the format tape.
  - 10) Lower splicer arm on tape splice and press the arm down to join the tape ends with the splice.
  - 11) Remove tape from the splicer, turn tape inside out, reverse it, and apply another splice on the other side using the method described in steps 9 through 11. In applying a second splice, offset it slightly from the first (one or two drive sprocket holes) to reduce the abruptness in the thickness change as the spliced area of the tape passes through the format tape reader. The format tape is always installed with its drive sprocket holes toward the centerline of the printer.

### **Paper Basket Operation**

The paper basket for the 70-LPM printer consists of two pieces: a paper basket mounting rack and a paper basket. The paper basket mounting rack is mounted to the rear of the printer by hooking it over the paper tensioner shaft. Figure C2-9 shows the paper basket in the lower mounting position.

The paper basket mounts to the paper basket mounting rack in what is called the upper basket mounting position. This is used when the printer is table mounted, and the forms supply is located on the table behind the printer.

Both pieces of the paper basket must be removed before removing the upper cabinet cover.

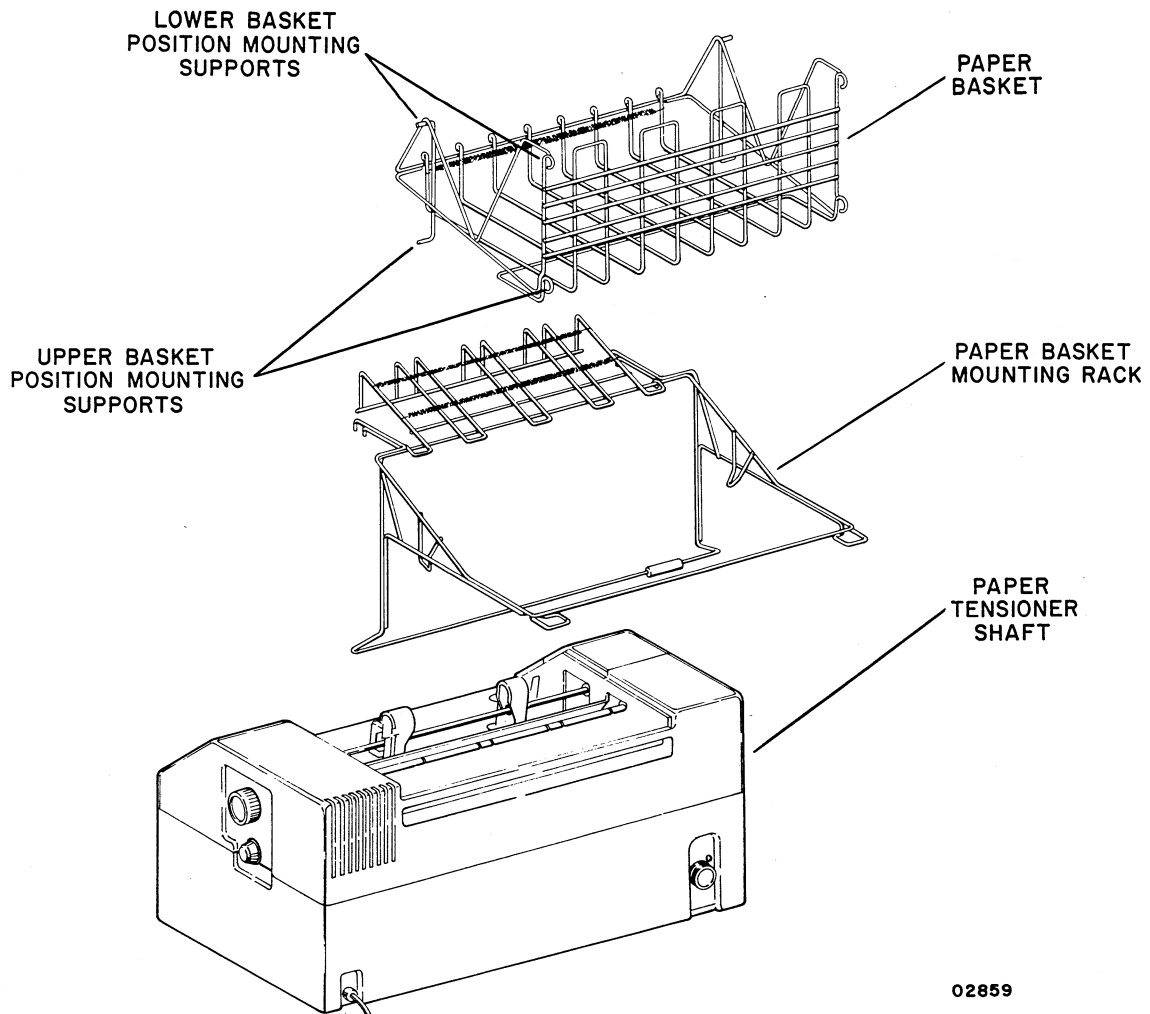

Figure C2-9. Paper Basket Operation

### Printhead Replacement

This procedure describes the removal and replacement of the printhead used on the 70-LPM printer.

To replace the printhead, perform the following:

- 1) Disconnect printer line cord from power source.
- 2) Remove front cover to gain access to the printhead (refer to Front Cover Removal and Replacement procedure).
- 3) Remove ribbon cassette (refer to Ribbon Cassette Replacement procedure).

- 4) Reach under printhead support casting with your fingers and unplug the printhead harness connector from the printhead flat cable connector.
- 5) Unclamp printhead from support casting by grasping the right and left clamping levers (one with either hand) and pull the levers toward the sides of the printer until they are disengaged from the printhead.
- 6) Remove printhead harness from retaining hook located under the printhead support casting (figure C2-10).
- 7) Slide printhead toward front of the printer, remove it from printhead support casting, and lift out of printer.
- 8) Mount new printhead to printhead support casting. Note that the hole on either side of the printhead should be slid over the guide pins on either side of the mounting surface on the printhead support casting. Slide printhead toward the rear of the printer until it is seated against the mounting surface on the support casting.

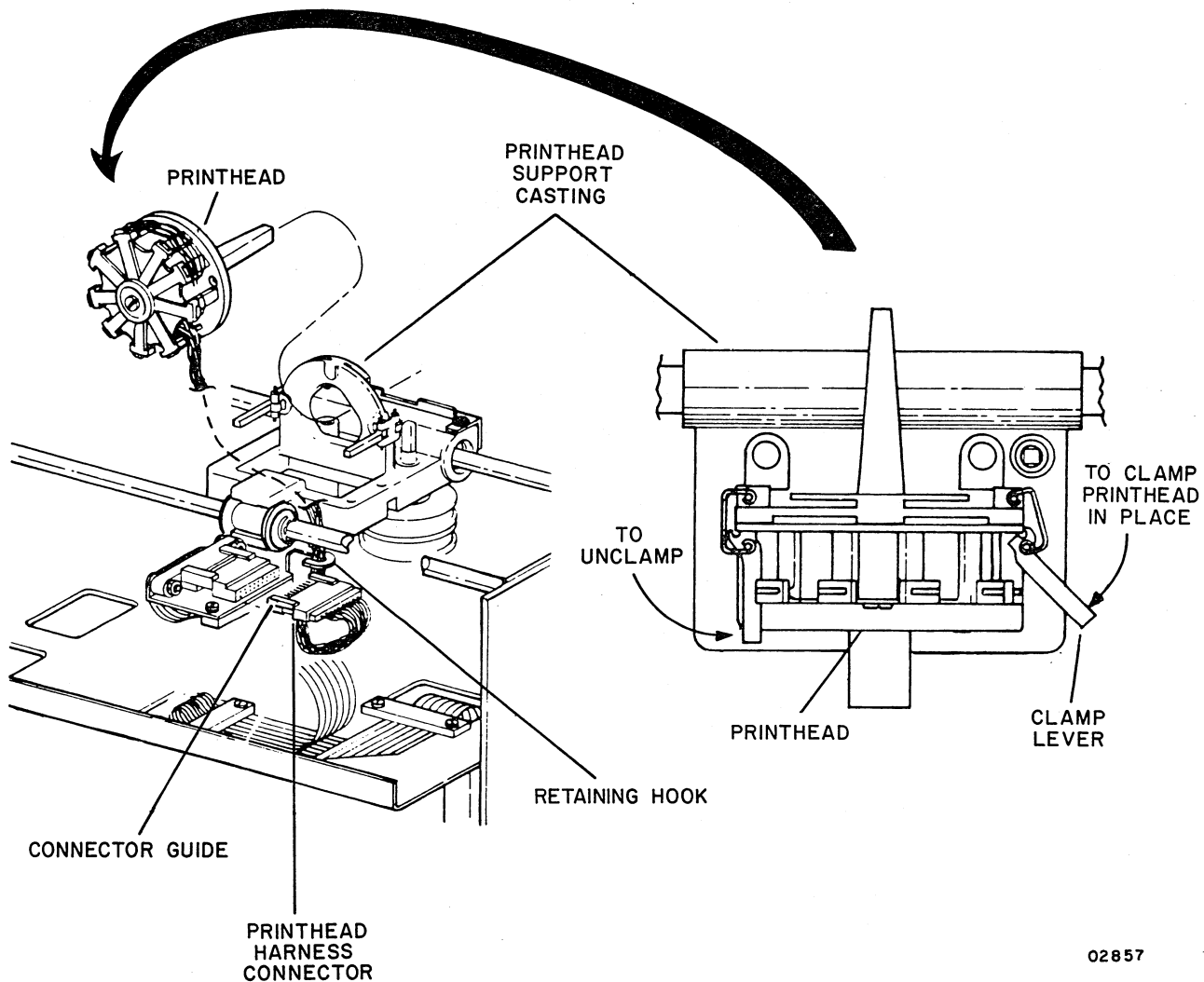

Figure C2-10. Printhead Replacement

## NOTE

Care should be taken to ensure that the notches on the clamp levers are placed on the corner of the printhead before clamping the printhead in place.

- 9) While holding the printhead against the mounting surface of the support casting with one hand, clamp it in place with the two clamping levers (figure C2-10).
- 10) Route the printhead harness and connector as shown in figure C2-10 and plug the printhead harness connector into the printhead flat cable connector. Note that the printhead harness connector guides should be on top when making connection. Also ensure that the printhead harness has been placed behind the retaining hook.
- 11) Grasp printhead support casting and move it from one side of the printer to the other making sure that the printhead harness does not rub on the front support shaft or hit on the side of the printhead structure. Adjust the harness in the retaining hook as necessary.
- 12) Replace the ribbon cassette (refer to Ribbon Cassette Replacement procedure).
- 13) Replace front cover and ensure that it is seated properly. Refer to Front Cover Removal and Replacement procedure.
- 14) Connect printer line cord to power source.
- 15) Load paper and start printing. Adjust Forms Density Control knob as required.

## OPERATOR SUPPLIES

The following paragraphs list the recommended supplies for the 70-LPM printer.

### FORMS RECOMMENDATIONS

The printer will handle standard continuous forms with feed holes on each edge, with or without marginal perforations.

The forms may be from 4 to 16.7 in (10.16 to 42.5 cm) in width including margins, and 3.5 to 17 in (8.89 to 43.18 cm) long from fold to fold. When using the output paper basket, the forms length is limited to 12 in (30.48 cm) from fold to fold.

The forms must have sprocket holes punched along both margins  $0.25 \pm 0.03$  in ( $0.635 \pm 0.076$  cm) from the paper edge to the centerlines. The distance between hole centerlines must be  $0.500 \pm 0.005$  in ( $1.27 \pm 0.013$  cm) nonaccumulative, and the diameter of the holes should be  $0.156 \pm 0.010$  in ( $0.396 \pm 0.025$  cm). The distance across the sheet between sprocket hole centerlines must be uniform within  $0.015$  in ( $0.038$  cm). Multiple-part forms shall be suitably locked with a nonmetallic locking device. Locking the right edge only is not recommended. The requirements for forms are in the following list.

Parts	White Sulphite Bond Paper	Carbon Paper
1	15 lb continuous bond ( $56 \text{ g/m}^2$ )	—
1	24 lb continuous bond ( $90 \text{ g/m}^2$ )	—
2 and 3	12 lb continuous bond ( $45 \text{ g/m}^2$ )	8 lb ( $14 \text{ g/m}^2$ )
2 and 3	15 lb continuous bond ( $56 \text{ g/m}^2$ )	8 lb ( $19 \text{ g/m}^2$ )
4 and 5	12 lb continuous bond ( $45 \text{ g/m}^2$ )	6 lb ( $14 \text{ g/m}^2$ )

### RIBBON RECOMMENDATIONS

The ribbon used in this printer consists of a disposable ribbon cassette (CDC part number 44671690) that snaps over the printhead and engages a cassette drive shaft on the support assembly. Each ribbon cassette contains an endless loop of nylon ribbon that is cycled through the cassette in one direction until the end of ribbon life is reached.

### FORMAT TAPE RECOMMENDATIONS

The format tape is a standard 1 in (2.54 cm) wide paper tape with drive sprocket holes of 0.10 in (0.254 cm) centers. The standard format tape has three channels: channel 1 should be punched to correspond to the top-of-forms positions; channel 2 may be punched at any vertical tab desired; channel 3 is line feed and is not punched because the printer has an automatic line-feed control circuit (either 6/8-line-per-inch mode). The format tape may be any length from 5.5 to 12.5 in (13.97 to 31.75 cm). The recommended format tape punch, format tape, and format tape splices are as follows.

<u>Item</u>	<u>CDC Part Number</u>
Format tape punch	76657900
Standard format tape	95414500
Format tape splices	76628200



---

Refer to section 4 of the existing manual for the character and symbol code listings and dot-matrix symbol formations for the 70-LPM impact printer.



---

This section provides information for crating, uncrating, and installing the 70-LPM impact printer. Also included are instructions for handling PC cards.

## CRATING

The following paragraphs and figure C4-1 describe the crating procedures for the 70-LPM printer.

To protect against shipping damage, always prepare an equipment for shipment using only approved procedures and materials. To obtain proper procedures and materials, contact your nearest CDC representative or:

Control Data Corporation  
Corporate Traffic  
8100 34th Avenue South  
Minneapolis, Minnesota 55440

## UNCRATING

The following paragraphs describe uncrating procedures for the 70-LPM impact printer, PC card modules, and miscellaneous printer components.

### 70-LPM IMPACT PRINTER

To uncrate the 70-LPM printer, refer to figure C4-1 and perform the following steps:

- 1) Cut and remove the steel strapping holding shipping container to skid.
- 2) Open top of shipping container and remove manuals and cabling on top of printer top cushion.
- 3) Remove top cushion from top of printer.

CRATING NOTES:

- 1) USE CRATING KIT 59126300.
- 2) SECURE FLOATING PRINTER MECHANISM TO PRINTER BASE PLATE BY INSTALLING TWO M6x8 SHIPPING SCREWS THROUGH BOTTOM OF BASE PLATE AND INTO PRINTER MECHANISM.
- 3) TAPE PRINthead SUPPORT CASTINGS AND PAPER WEIGHTS IN PLACE WITH FILAMENT TAPE (59136109).
- 4) ASSEMBLE PRINTER EXTERIOR CONTAINER (59126301) USING CARTON SEALING TAPE (59136111).
- 5) PLACE PRINTER EXTERIOR CONTAINER ON SHIPPING SKID (59126310).
- 6) PLACE BOTTOM CUSHION (59126302) IN BOTTOM OF EXTERIOR CONTAINER.

CAUTION

PRINTER WEIGHS APPROXIMATELY 100LB (45.4 KG).  
GET ASSISTANCE TO PLACE PRINTER IN EXTERIOR  
CONTAINER TO PREVENT BODILY INJURY AND/OR  
DAMAGE TO PRINTER.

- 7) PLACE PRINTER IN EXTERIOR CONTAINER AND ON BOTTOM CUSHION.
- 8) PLACE DUST COVER (59125407) ON TOP OF PRINTER.
- 9) PLACE TOP CUSHION (59126303) ON TOP OF PRINTER AND DUST COVER.
- 10) PLACE PRINTER MANUAL AND CABLES ON TOP OF TOP CUSHION.
- 11) CLOSE TOP FLAPS OF EXTERIOR CONTAINER AND SEAL WITH CARTON SEALING TAPE.
- 12) STRAP CONTAINER TO SHIPPING SKID USING STEEL STRAPPING (59136107) AND EDGE PROTECTORS (59136123).

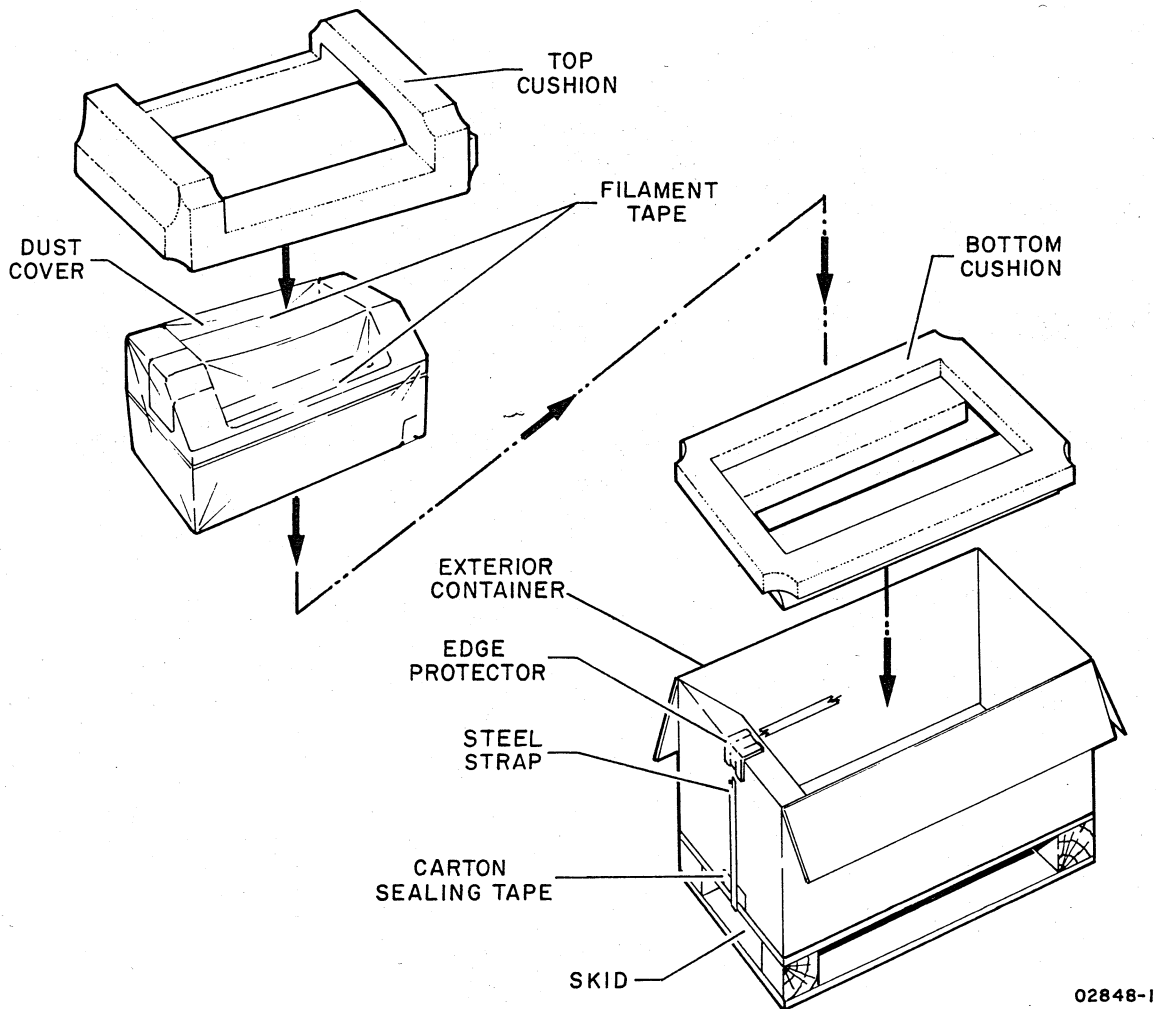

Figure C4-1. Crating and Uncrating the 70-LPM Impact Printer

- 4) Remove dust cover from printer by pulling it up and off of printer.

### CAUTION

The 70-LPM printer weighs approximately 100 lb (45.4 kg). Get assistance to remove printer from shipping container to prevent possible bodily injury and/or damage to the printer.

- 5) Carefully lift printer from shipping container and place it on a solid, level surface.
- 6) Remove filament tape and any wrapping or packing material used to secure printhead and paper weights during shipment.
- 7) Remove two M6x8 machine screws that secure the floating printer mechanism to printer base plate. These screws are accessible from bottom of the printer; however, do not tip printer up on its cabinet to access these screws. Overhang one end of the printer at a time from a stable workbench or table to reach these shipping screws.
- 8) Inspect printer for possible damage during transit.

### **PC CARD MODULES**

To unpack any circuit modules, refer to the Installation Instructions section, appendix A, of the existing manual.

### **MISCELLANEOUS PRINTER COMPONENTS**

When unpacking any replacement components for 70-LPM printer, always proceed carefully and remember the following:

- 1) Preserve the condition of the shipping container and packing material for later use in returning a malfunctioning component or equipment for repair.
- 2) Observe the manner in which a received item is packed so that the return item can be packed in a similar manner.

## INSTALLATION

Install the 70-LPM printer on a level surface, so that the printer weight is resting evenly over all four rubber feet.

If the printer is to be installed on a table, bench, or cabinet, level the top surface before placing the printer on it. In general, the printer will operate on a fairly level surface as long as it is not allowed to rock. The main reason for requiring that the printer be level is for form feed purposes.

The following procedure gives the steps for installing the 70-LPM printer.

### CAUTION

The 70-LPM printer weighs approximately 100 lb (45.4 kg). Be careful when lifting or moving the printer so as not to injure yourself or damage the printer.

- 1) Remove the printer unit from shipping container according to the preceding uncrating instructions.
- 2) Place the printer unit near its associated keyboard display terminal. Ensure that surface on which printer is placed is firm, stable and level, and that there is space around printer for performing routine maintenance and operating tasks. The spacing shown in figure C4-2 is recommended as a minimum.
- 3) Remove upper cabinet cover, side cover, and front cover of printer (refer to specific cover removal and replacement procedures).
- 4) Swing down interface adapter frame and PC board, mounted vertically at rear of printer, by releasing plastic latch at each upper end of frame and letting top edge of frame down until frame is horizontal.
- 5) Swing down controller and printhead PC board (next board in from rear of printer chassis) in the same manner as used for the adapter interface board in the preceding step.
- 6) Swing down the power supply PC board (3rd board in from rear of printer) in same manner as used in steps 4 and 5.

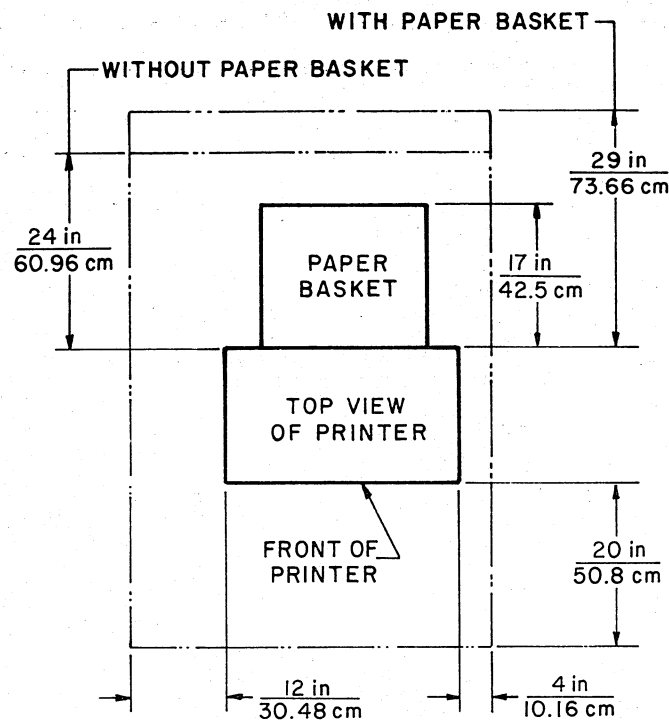

02879

Figure C4-2. Printer Dimensions

- 7) Measure ac voltage level at site power outlet with an ac voltmeter, and ensure that power wiring between circuit breaker 3CB01, terminal block 2TB01, and the primary of input transformer 2T01 is appropriately connected for the measured input voltage level. The circuit breaker, terminal block, and input power transformer are all located near the right side of the printer chassis from the front. The input power transformer has connections for voltage input levels of 100, 120, 200, 220, 240, and 260 V ac; see figure C4-3 and alter input power wiring as necessary to most closely match available input power (measured voltage level).
- 8) If 50-Hz power is the only input power available at site, clip off standard 60-Hz input power plug and replace it with an appropriate 50-Hz power plug. See figure C4-3 for color coding and terminal wiring of input power cord wires and transformer.
- 9) Swing power supply PC board back up into printer chassis. Ensure that board latches engage the proper holes in chassis frame and that board is securely held in chassis in a vertical position.

100 V/120 V

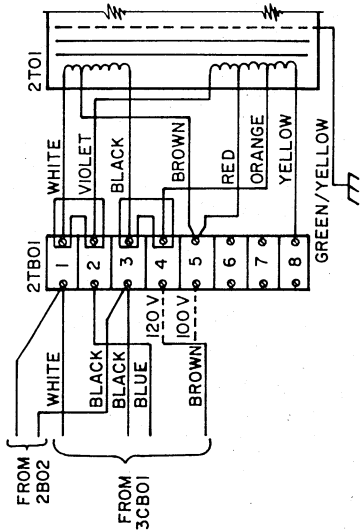

230 V/260 V

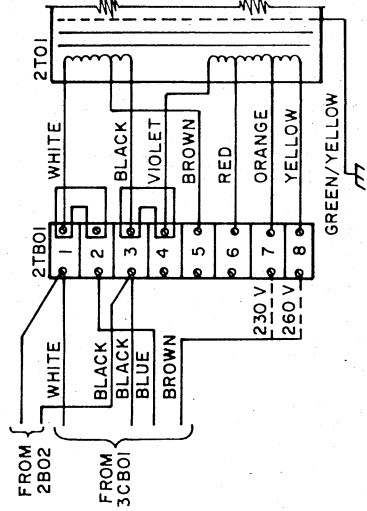

200 V/220 V/240 V

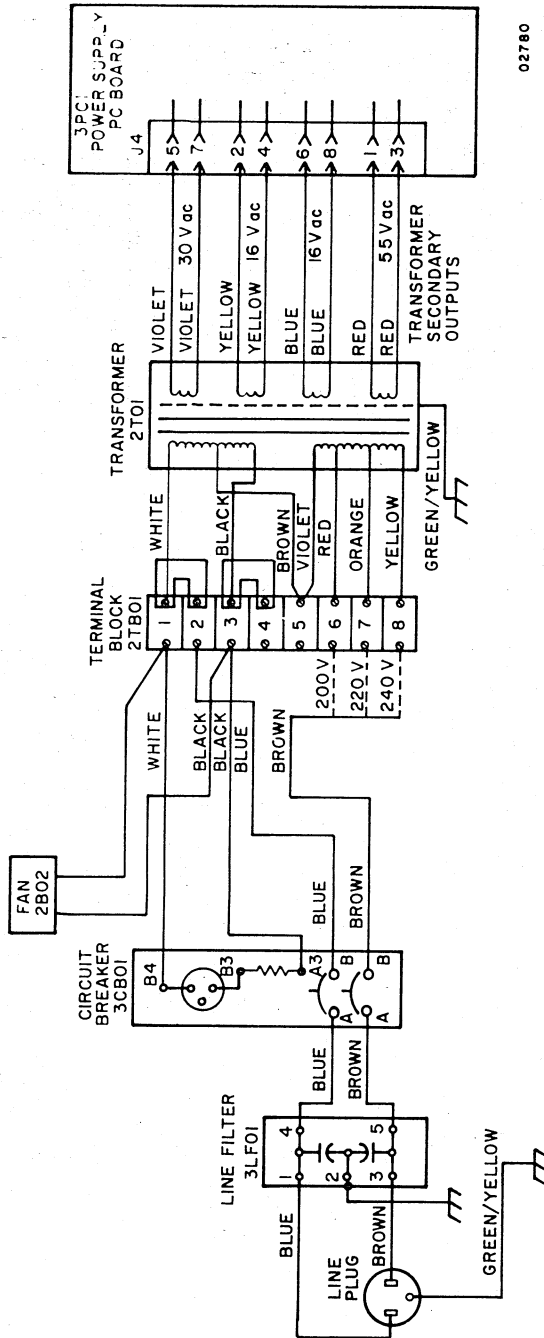

02780

Figure C4-3. Alternate Power Configuration for Wiring the Universal Transformer

10) Locate switch bank SWN4 on controller and printhead PC board (approximately location F6 on board), and set eight SWN4 switches as follows (figure C4-4):

- SWN4-1 Off
- SWN4-2 Off
- SWN4-3 Not used
- SWN4-4 Not used
- SWN4-5 On or off (user's choice)
- SWN4-6 Off
- SWN4-7 Off
- SWN4-8 Off

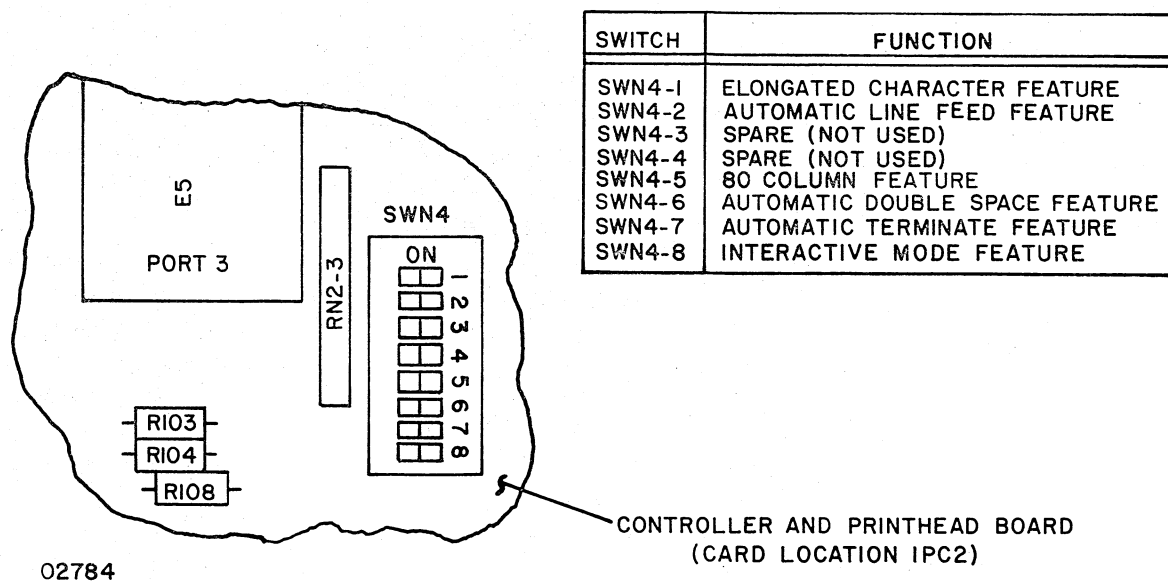
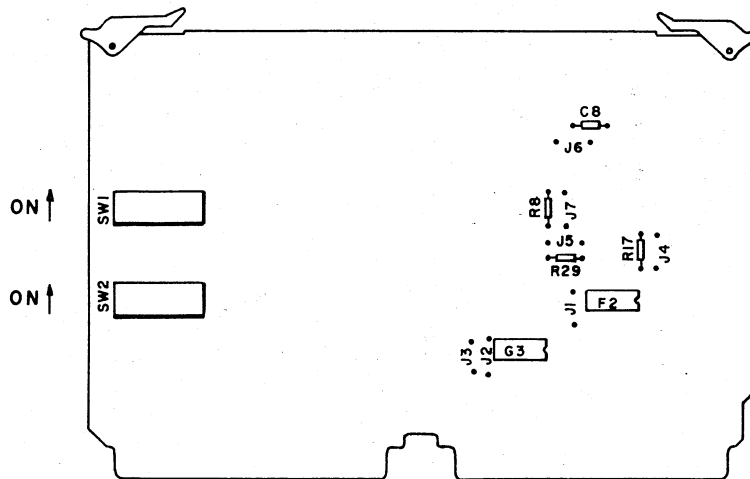

Figure C4-4. Location and Functions of SWN4 Switches

- 11) Swing controller and printhead board back up into printer chassis. Ensure that board latches engage proper holes in chassis frame so that board is securely held in chassis in a vertical position.
- 12) Using figure C4-5 as a guide, set the printer baud rate and parity select switches, located in the interface adapter PC board, to match those of the keyboard display (refer to Installation Instructions, appendix A, of the existing manual for Keyboard Display Installation procedure). Baud rate for terminals using a 70-LPM printer should not exceed 2400 baud.

	BAUD RATE SELECTION 150	BAUD RATE SELECTION 300	BAUD RATE SELECTION 600	BAUD RATE SELECTION 1200	BAUD RATE SELECTION 1800	BAUD RATE SELECTION 2400	BAUD RATE SELECTION 4800	BAUD RATE SELECTION 9600	REC CLOCK TIME 416 USEC	REC CLOCK TIME 208 USEC	REC CLOCK TIME 104 USEC	REC CLOCK TIME 52 USEC	REC CLOCK TIME 35 USEC	REC CLOCK TIME 26 USEC	REC CLOCK TIME 15 USEC	REC CLOCK TIME 6.5 USEC
J01																
J02																
J03																
J04																
J05										X						
J06																X
SW1-1	ON	OFF	OFF	OFF	OFF	OFF	OFF	OFF								
SW1-2	ON	ON	OFF	OFF	ON	OFF	OFF	OFF								
SW1-3	OFF	ON	ON	OFF	OFF	OFF	OFF	OFF								
SW1-4	OFF	OFF	ON	ON	OFF	OFF	ON	OFF								
SW1-5	ON	ON	ON	ON	ON	OFF	ON	OFF								
SW1-6	ON	ON	ON	OFF	OFF	OFF	OFF	OFF								
SW1-7	ON	ON	OFF	OFF	ON	ON	OFF	ON								
SW1-8	ON	OFF	OFF	ON	OFF	ON	ON	ON								
SW2-1									ON	ON	OFF					
SW2-2									OFF	ON						
SW2-3											ON	ON	OFF	OFF		
SW2-4											ON	OFF	ON	OFF		
SW2-5	ON	ON	ON	ON	OFF	ON	OFF	OFF								
SW2-6	OFF	OFF	OFF	OFF	ON	OFF	ON	ON								
J07											X	X	X			



**NOTES:**

1) TO USE THE PRINTER ON OTHER BAUD RATES THAN SHOWN ABOVE, THE FOLLOWING FORMULA CAN BE USED

$$\text{LOAD VALUE IN DECIMAL} = 256 - \left( \frac{1}{32(\text{BAUD RATE})A} \right)$$

WHERE:

A =  $1 \times 10^{-6}$  FOR SWITCHES SW2-5 CLOSED AND SW2-6 OPEN.

A =  $0.25 \times 10^{-6}$  FOR SWITCHES SW2-6 CLOSED AND SW2-5 OPEN.

THE LOAD VALUE IN DECIMAL MUST THEN BE CONVERTED INTO BINARY. THEN, THAT VALUE IS LOADED INTO THE SWITCHES.

2) SWITCHES SW2-5 AND SW2-6 CAN NEVER BE CLOSED OR OPEN AT THE SAME TIME. IF EITHER OF THESE OCCURS, EITHER A WRONG FREQUENCY OR NO FREQUENCY IS SUPPLIED TO THE BAUD RATE SELECTOR.

Figure C4-5. 70-LPM Impact Printer Internal Switches and Jumpers

02290-1

- 13) Set data bit switches and jumper on interface adapter PC board (see figure C4-5) to correspond with parity selection made in preceding step: if odd or even parity is selected, select 7 data bits; if no parity is selected, select 8 data bits.
- 14) Remove interface adapter board jumpers for auto answering and reverse channel; alarm jumpers and buffer overflow jumper removal is selective (user determined).
- 15) Swing interface adapter PC board and frame back up into printer chassis. Ensure that board latches engage proper holes in chassis frame so that board is securely held in chassis in a vertical position.
- 16) Check to see that format tape is properly installed in electronic vertical format unit (EVFU) drive mechanism, which is located on left side (from front) of printer chassis. If format tape requires punching, refer to Format Tape Punching procedure. If format tape requires installation, refer to Format Tape Load Operation procedure.
- 17) Set printer ON/OFF power switch to OFF position, and remove printer ac power plug from site outlet.
- 18) Install printer cabinet (refer to specific cover removal and replacement procedure).
- 19) Plug printer power cord in appropriate site ac power outlet.
- 20) Unpack the printer paper basket by removing the two-piece basket, the grounding strip bracket assembly, the bag of assembly hardware, and the basket assembly instructions from shipping container.
- 21) Check parts against the assembly instructions to ensure that none of the paper basket parts are missing or damaged.
- 22) Mount the grounding strip bracket assembly to printer base plate (refer to Paper Basket Operation procedure).
- 23) Connect RS-232-C/CCITT V.24 type I/O cable from rear of display terminal PERIPHERAL CONNECTOR to printer rear panel connector.
- 24) Plug printer power cord in appropriate site outlet.



---

This section discusses the print rate of the 70-LPM impact printer. Primarily, this is for the sake of pointing out when idle characters are required in the data stream to prevent lost data. Accordingly, two things must be considered, the print rate per line length and the printer 1K buffer fill rate.

## PRINT RATE PER LINE LENGTH

Figure C5-1 shows the lines per minute (LPM) printed by the 70-LPM printers respectively, at varying printline lengths. To calculate actual print rate in characters per second (CPS):

- Multiply characters per line (CPL) to be printed by the LPM value shown in the appropriate figure.
- Divide the product by 60.

Example print rate calculations for the 70-LPM printer (figure C5-1):

- $132 \text{ CPL} \times 70 \text{ LPM} = 9240$ ;  $9240 \div 60 = 154 \text{ CPS}$
- $20 \text{ CPL} \times 230 \text{ LPM} = 4600$ ;  $4600 \div 60 = 76.7 \text{ CPS}$

As the preceding examples show, the slower printing rates of both printers are when printing short lines; and when printlines are longer, the printing rate is faster.

## PRINTER 1K BUFFER FILL RATE

The 1K (1024 word) buffer of the 70-LPM printer stores and receives codes except for BEL, NUL, and DEL. Received character codes remain in the buffer until the printline they represent is the next line to be printed. Thus, with a continuous data stream, the buffer fill rate equals the characters received per second (CRPS),  $1/10$  the communication baud rate, minus the CPS print rate. For example, with a

1200 baud rate and a print rate of 100 CPS, the buffer fill rate is 20 CPS (120 CRPS-100 CPS=20 CPS). At this rate, it takes 51 seconds to fill the buffer ( $1024 \div 20 \text{ CPS}=51$ ). Within 51 seconds, a continuous data stream would contain 6120 characters.

As the example illustrates, the buffer will not fill under most operating conditions. However, with a relatively high baud rate, the buffer may fill if the data stream is long with many short printlines. In this case, NUL or DEL codes must be in the data stream to give the printer idle time, or data will be lost. Figure C5-2 shows the idle requirements of the 70-LPM printer when the communication rate is 1200 baud.

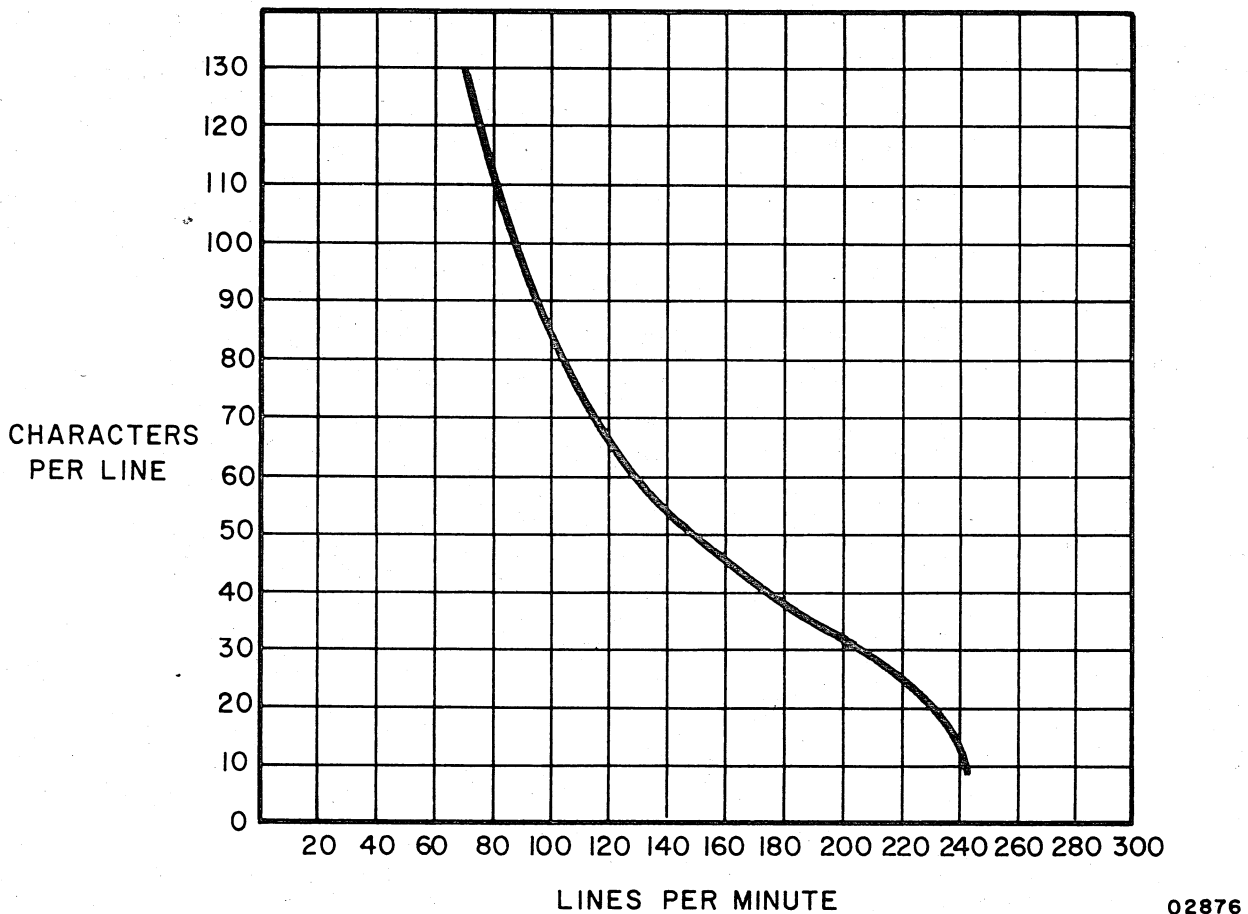
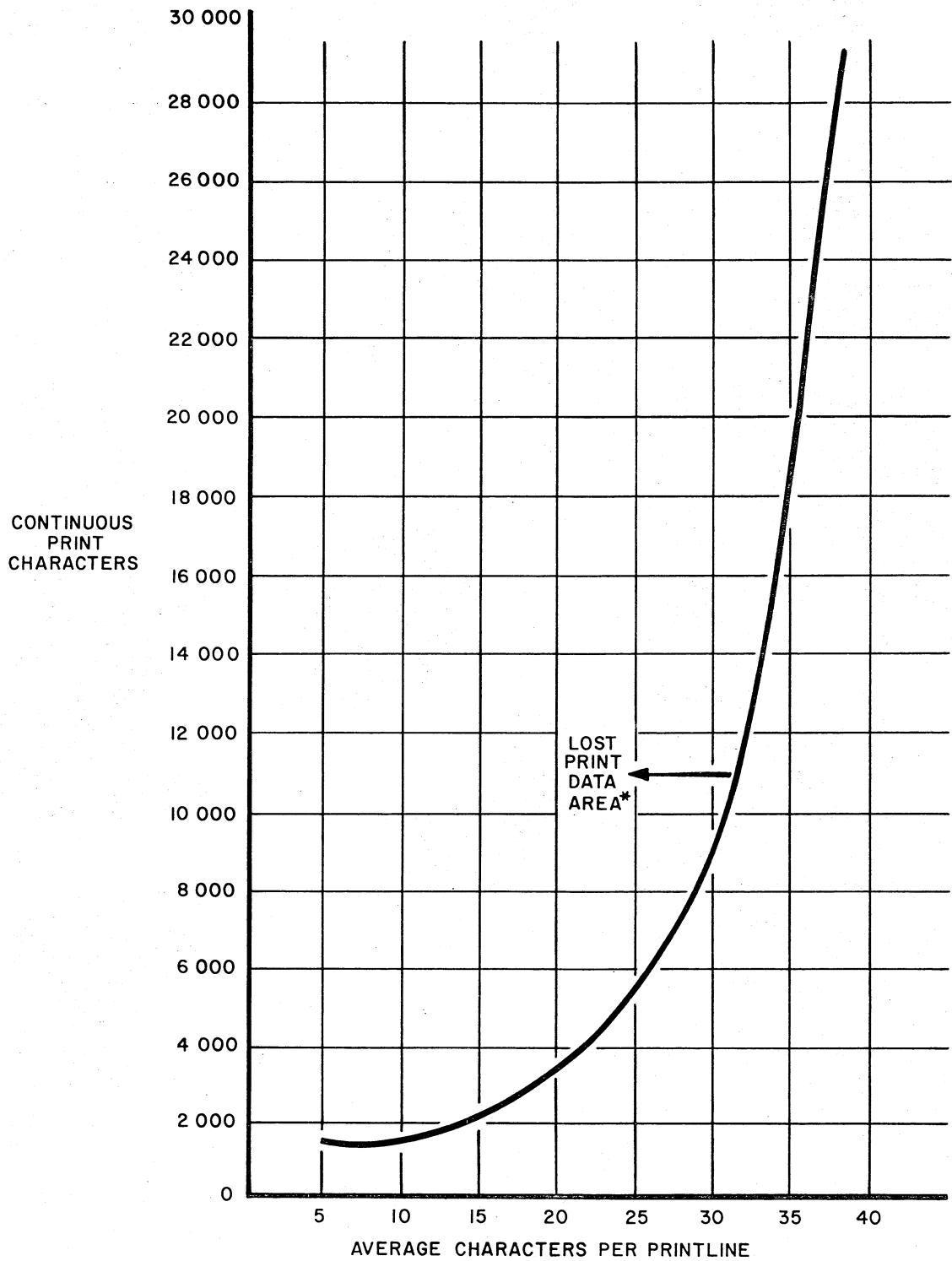

Figure C5-1. 70-LPM Impact Printer Print Rates at Varying Line Lengths



\*NUL OR DEL CHARACTERS REQUIRED IN DATA STREAM TO PREVENT LOST DATA

02875

Figure C5-2. 70-LPM Printer Idle Requirements at 1200 Baud



---

This appendix describes the 82-key typewriter keyboard. It is one of three detachable keyboards available with the 752 display terminal subsystem. The other two detachable keyboards, the 80-key ISO\* and the 80-key FTZ licensed units, are described in the existing manual.

Because of the many similarities between the 82-key keyboard and the 80-key ISO keyboards, this appendix will be used in conjunction with the existing manual breakdown or format.

## GENERAL DESCRIPTION

Differences in the 82-key typewriter keyboard are described under the following headings (section 1 of the existing manual):

- Keyboard Features
- Operator-Control Features
- Features Summary List

## KEYBOARD FEATURES

Substitute the following paragraph for the first paragraph under Keyboard Features and figure D-1 for the Keyboard Layout figure (section 1).

The 82-key keyboard serves as both a terminal control and a data input unit for the terminal operator. The terminal control function of the keyboard is discussed later in this appendix under the heading Keyboard Data Entry and Control Keys. The keyboard uses a main cluster of 68 keys, similar in appearance to a standard teletypewriter keyboard, and a 14-key numeric-entry cluster, to facilitate making numeric entries, located just to the right of the main key cluster (figure D-1).

---

\* International Standards Organization.

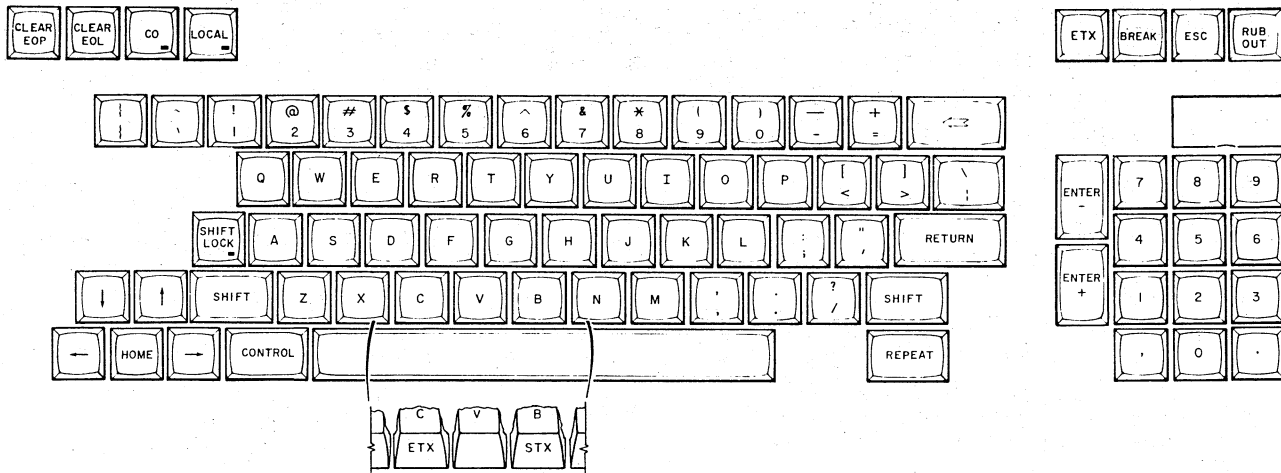

02630-5

Figure D-1. 82-Key Keyboard Layout

## OPERATOR-CONTROL FEATURES

Substitute the following paragraph, listing, and caution for the first paragraph and listing under the heading Operator-Control Features (section 1).

The following list notes those switches which previously on the 80-key keyboard were located across the top of the keyboard and which on the 82-key keyboard are all located under a lift-cover just above the numeric cluster (figure D-2). These switches are now two position rather than three-position toggle switches.

- 96/64 switch
- FULL/HALF Duplex switch
- 300/HIGH Baud Rate switch\*
- 300/LOW Baud Rate switch\*
- NO PARITY/ODD PARITY switch\*\*
- NO PARITY/EVEN PARITY switch\*\*
- PAGE/SCROLL switch

\* 300/HIGH Baud Rate and 300/LOW Baud Rate switches, formerly combined as one switch, are now two separate switches.

\*\* NO PARITY/ODD PARITY and NO PARITY/EVEN PARITY switches, formerly combined as one switch, are now two separate switches.

## CAUTION

Use a ballpoint pen to set switches (under the keyboard lift-off cover); do not use a lead pencil to set switches. Graphite dust from the pencil can cause an equipment malfunction.

### **FEATURES SUMMARY LIST**

Add the following items for the 82-key keyboard to the Features Summary List (section 1).

- 82-key typewriter keyboard with a 68-key main cluster and 14-key numeric-entry cluster
- Cursor controls: up, down, left, right, and HOME
- Typamatic keys — when the key is pressed and held, the repeat feature is activated without having to press the REPEAT key

### **OPERATION**

Differences in operation of the 82-key keyboard are described under the headings (section 2):

- External Controls and Indicators
- Keyboard Data Entry and Control Keys
- Typamatic Keys

## EXTERNAL CONTROLS AND INDICATORS

The external controls and indicators previously mentioned under Operator-Control Features have a new location on the 82-key keyboard (figure D-2). The only switch with any significant change is the 96/64 switch, as noted in the following paragraphs.

Substitute figure D-2 in place of the External Controls, Keyboard and Front Panel, figure in section 2.

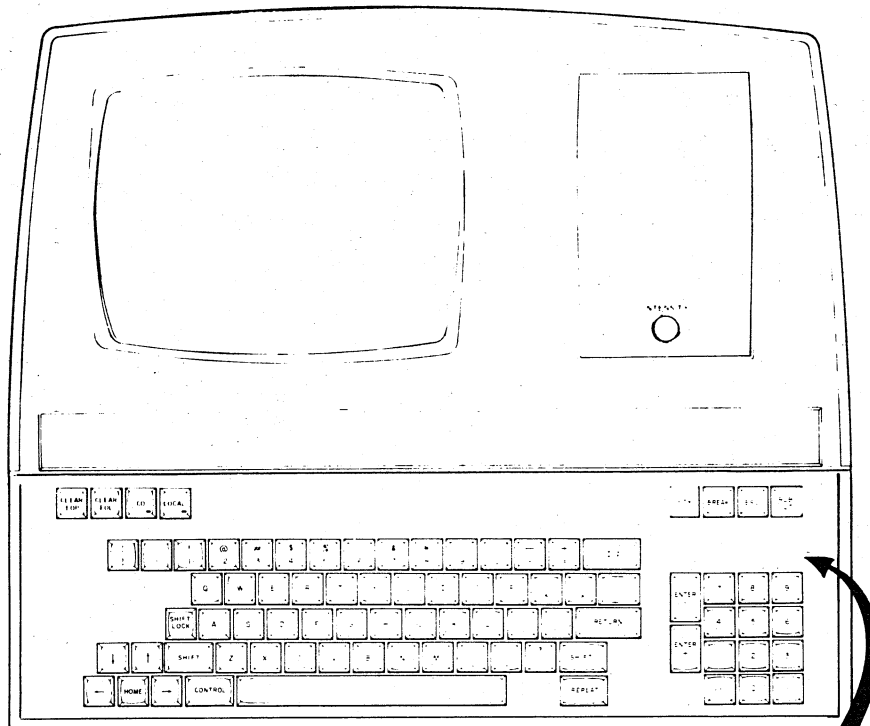

02450-4

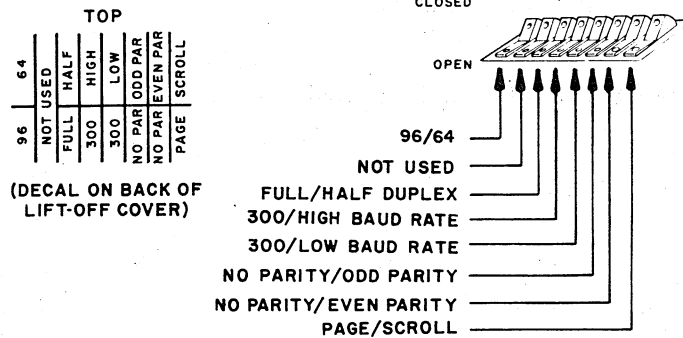

Figure D-2. 82-Key Keyboard and Operator-Control Features

## 96/64 Switch







Add the following paragraphs and table D-1 to the existing paragraph under the heading 96/64 Switch in section 2 of the existing manual.

With the switch in the 96 position, lowercase letters and symbols ( ` , { , } , | , and ~ ) may be entered from the keyboard. In the 64 position, letters are uppercase regardless of SHIFT or SHIFT LOCK key use and the previous symbols are replaced by:

- @ (commercial at) instead of grave accent
- [ (left bracket) instead of left brace
- ] (right bracket) instead of right brace
- \ (reverse slant) instead of vertical line
- ^ (caret) instead of swung dash

The association between key and generated symbols, however, is affected by the 96/64 switch under the keyboard lift-off cover. If the 96/64 switch is set to the 64 position, lowercase letters and key symbols imprinted in yellow are disabled. Table D-1 shows the affect this has to the yellow symbol keys.

TABLE D-1. YELLOW KEY-SYMBOL GENERATION WITH 64-CHARACTER SELECTION

82-KEY KEYBOARD	
KEYS ACTUATED	SYMBOL GENERATED
	@
 + SHIFT or SHIFT LOCK	^
	\
 + SHIFT or SHIFT LOCK	\
	[
 + SHIFT or SHIFT LOCK	]

## KEYBOARD DATA ENTRY AND CONTROL KEYS

The keyboard data-entry and control keys whose operation differs from those described in section 2 of the existing manual are as follows:

- CLEAR EOL key
- CONTROL key
  - Fixed Code keys
  - Cursor Movement keys
- STX (Control/B keys)
- ETX (Control/C keys)
- RETURN key
- Cursor Down (↓) key
- HOME key

In addition, the LINE FEED key is deleted when discussing the 82-key keyboard.

### CLEAR EOL Key

Add the CLEAR EOL key following the heading CLEAR key and its description in section 2 of the existing manual.

Pressing the CLEAR EOL key clears all unprotected characters from the present cursor position to the end of the line containing the cursor. The cursor does not move.

Pressing the CLEAR EOL key causes transmission of a SYN control function code and initiates the line clear operation.

### CONTROL Key

Under the CONTROL Key in section 2, the following paragraphs should replace those identified as Fixed-Code Keys and Cursor Movement Keys.

## Fixed Code Keys

Substitute the following list for the 82-key keyboard in place of the existing list under the heading Fixed Code Keys in section 2.

The following eight fixed code keys have codes that may also be accessed via actuation of the CONTROL key plus a character key.

<u>Fixed Code Key</u>	<u>ASCII Mnemonic</u>	<u>Equivalent</u>
CLEAR	CAN	CONTROL plus X
CLEAR EOL	SYN	CONTROL plus V
HOME	EM	CONTROL plus Y
↑	SUB	CONTROL plus Z
↓	LF	CONTROL plus J
→	NAK	CONTROL plus U
ENTER-	FS	CONTROL plus M
ENTER+	GS	CONTROL plus H

## Cursor Movement Keys

Substitute the following list for the 82-key keyboard in place of the existing list under the heading Cursor Movement Keys in section 2.

<u>Keys</u>	<u>ASCII Mnemonic</u>	<u>Function</u>
RETURN	CR	Returns cursor to left margin
←	BS	Backspaces cursor
CLEAR	CAN	Clears display and resets cursor
CLEAR EOL	SYN	Clears to end of line
HOME	EM	Repositions cursor to home position
↑	SUB	Moves cursor up a line
↓	LF	Moves cursor down a line
→	NAK	Moves cursor forward
CONTROL plus V	SYN	Clears a line from cursor to end of line; cursor does not move

<u>Keys</u>	<u>ASCII Mnemonic</u>	<u>Function</u>
CONTROL plus N*	SO	Initiates reduced intensity and advances cursor one space
CONTROL plus O*	SI	Ends reduced intensity or blink (highlight) field and advances cursor one space
CONTROL plus W*	ETB	Initiates blink and advances cursor one space

### **STX (CONTROL/B Keys)**

Add the STX key in the description of the 82-key keyboard under the heading Keyboard Data Entry and Control Keys in section 2 of the existing manual.

In block mode, using the CONTROL key in combination with the B key\*\* defines the starting point of a block data transfer and stores an STX code at the current cursor position. In half-duplex character mode, the STX code generated by the keys is stored and transmitted.

### **ETX (CONTROL/C Keys)**

Substitute the following paragraph for the existing description under the heading ETX in section 2.

In block mode, using the CONTROL key in combination with the C key\*\*\* defines the termination point for a block data transfer.

### **RETURN Key**

The RETURN key on the 82-key keyboard has the same function as the CARRIAGE RETURN key on the 80-key keyboard.

---

\* Entry of SO, SI, or ETB codes without highlight feature in terminal still causes display of mnemonic character.

\*\* Front of keycap B to be engraved with STX.

\*\*\* Front of keycap C to be engraved with ETX.

## Cursor Down (↓)

Add the Cursor Down (↓) key to the existing text under the heading Cursor Positioning Keys.

This key functions the same as the Cursor Up key, except that the cursor motion is downward. Displayed data is not affected. The code is LF.

## HOME Key

The HOME key on the 82-key keyboard has the same function as the RESET key on the 80-key keyboard.

## TYPAMATIC KEYS

When any encoded key is pressed and held, the repeat feature is activated without having to press the REPEAT key. The following legends will be Typamatic when pressed (figure D-3):

- \_ (Underline)
- - (Hyphen)
- + (Plus)
- ⇐ (Backspace)
- ↓ (Cursor Down)
- ↑ (Cursor Up)
- X (Uppercase/lowercase)
- / (Slant)
- ← (Cursor Backspace)
- → (Cursor Skip)

There is a one-half second delay from the time the key is pressed until it repeats.  
 If CONTROL is pressed along with these keys, they will not repeat.

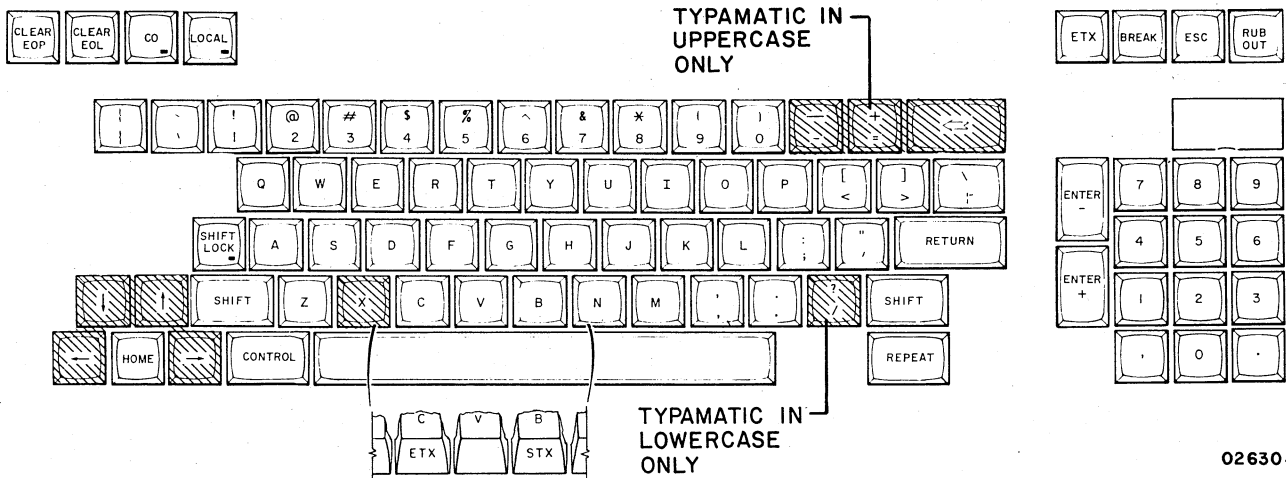

02630-5

NOTE: THE TYPAMATIC FUNCTION APPLIES TO UPPER- AND LOWERCASE UNLESS OTHERWISE NOTED.

Figure D-3. Typamatic Keys on 82-Key Keyboard

# KEYBOARD DISPLAY TERMINALS FOR SERIES/1 SYSTEMS

E

This appendix provides information on keyboard display terminals that are compatible with IBM\* Series/1 systems. The format of this appendix follows the sectional breakdown of the main body of this manual:

- General description
- Operation
- Subsystem communications
- Codes and character sets
- Installation

## GENERAL DESCRIPTION

The variations on the basic keyboard display terminal that provide a terminal compatible with Series/1 systems are outlined in table E-1.

TABLE E-1. SERIES/1-COMPATIBLE TERMINAL CONFIGURATIONS

EQUIPMENT CC555	60 Hz	50 Hz	CURRENT LOOP	FTZ SHIELDING	SELECTABLE STOP BITS	SUGGESTED KEYBOARD
-L	X	—	—	—	X	CA150E*
-M	X	—	X	—	X	CA150E*

\* The keyboard is available as separate equipment; it is described in appendix D of this manual.

The general functions, features, and equipment specifications provided under General Description in the main body of this manual apply to the Series/1-compatible terminals with only the exceptions and additions noted under the sections Display Unit and Keyboard, which follow.

\* IBM is a registered trademark of International Business Machines Corporation.

## DISPLAY UNIT

The display unit enclosure for the Series/1-compatible terminals is painted with white vinyl rather than gold vinyl. The display unit contains a selectable stop-bit switch and, if provided with current loop, has a current-loop feature compatible with the Series/1 current-loop communications interface (teletypewriter adapter). The display unit containing voltage level interface feature is compatible with Series/1 RS-232-C local or remote interface.\*

## KEYBOARD

Refer to appendix D, General Description section, for information on the keyboard. The keyboard differs from those described in appendix D only in color. The outside of the keyboard base for Series/1-compatible terminals is white rather than gold.

## OPERATION

The descriptions under Keyboard Display Controls and Indicators, Preparation for Operation, and Terminal Operation provided in section 2 of this manual apply also to the Series/1-compatible display units with the following additions (refer to appendix D for operation of the keyboard).

### KEYBOARD DISPLAY – INTERNAL CONTROLS

An additional internal control, the selectable stop-bit switch, is provided in the display unit of the Series/1-compatible terminal. The selectable stop-bit switch is located at position A8 on the control-logic printed-circuit (PC) board within the display unit (figures E-1 and E-2).

Put the stop-bit switch in the disable position to select one stop-bit operation. Put the switch in the enable position to select two stop-bit operation.

### KEYBOARD DISPLAY – INTERFACE JUMPERS

For the Series/1-compatible terminal with a voltage level interface capability, connect the jumpers as described in section 2, Interface Jumpers, of this manual. See figure E-1.

To prepare a terminal with current-loop capability for connection to the Series/1 current-loop communication interface, enable the current-loop switch at A9 and install jumpers as follows: A to C, J to D to G to E, H to L, and Q to R (figure E-2). All jumpers should have insulation on them.

---

\* Single line communication adapter, 4 or 8 line communication adapter, teletypewriter adapter (RS-232-C or current loop), and asynchronous local attachment feature.

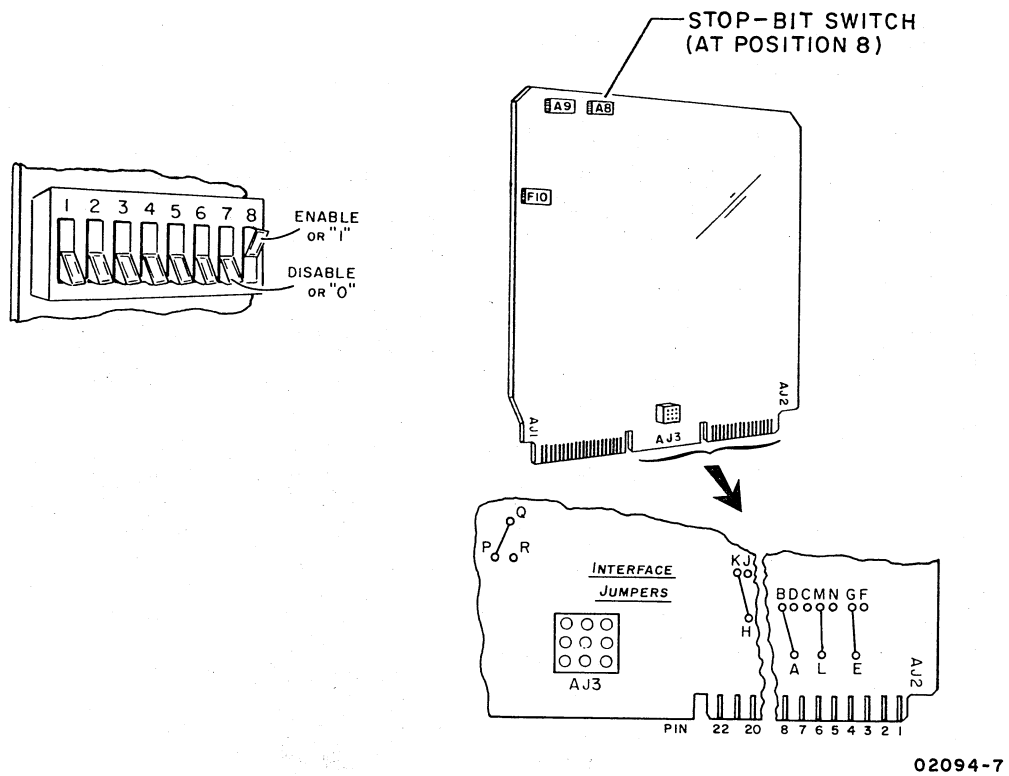

Figure E-1. Stop-Bit Switch and Interface Jumpers for Series/1 Voltage Level Communication Interface

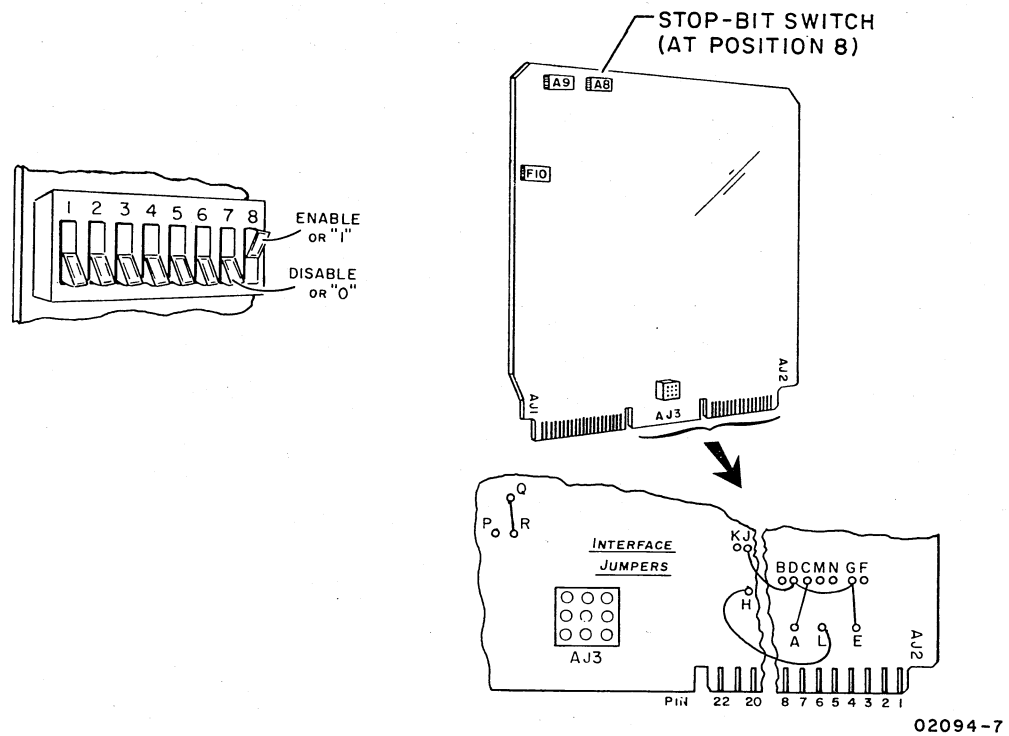
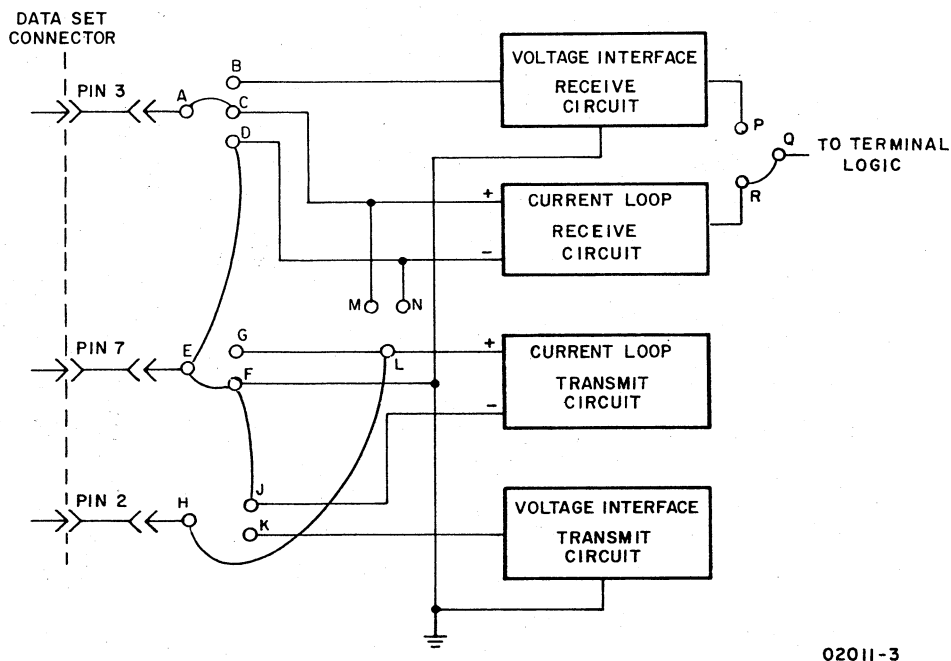

Figure E-2. Stop-Bit Switch and Interface Jumpers for Series/1 Current-Loop Interface Only

## SUBSYSTEM COMMUNICATIONS

The transmit/receive characteristics provided in section 3 of this manual also apply to the Series/1-compatible terminals with this exception: The number of stop bits (one or two) is selectable using the stop-bit switch provided on the control-logic PC board.

Figure E-3 is a schematic of the interface connections for the Series/1 current-loop communication interface.



02011-3

Figure E-3. Data Set Connector Pin Assignments for Series/1 Current-Loop Communication Interface

## CODES AND CHARACTER SETS

Codes and character sets used are identical to those described in section 4 of this manual.

## INSTALLATION

The installation instructions provided in appendix A of this manual also apply to the Series/1-compatible terminals. In addition, check the selectable stop-bit switch for desired setting. In a display unit with the current-loop capabilities, check jumpers for proper installation. Refer to figure E-2.



# COMMENT SHEET

MANUAL TITLE: 752 Keyboard Display Terminal  
Operators Guide/Reference Manual/Installation Instructions  
PUBLICATION NO.: 62957300 REVISION: F

NAME: \_\_\_\_\_

COMPANY: \_\_\_\_\_

STREET ADDRESS: \_\_\_\_\_

CITY: \_\_\_\_\_ STATE: \_\_\_\_\_ ZIP CODE: \_\_\_\_\_

This form is not intended to be used as an order blank. Control Data Corporation welcomes your evaluation of this manual. Please indicate any errors, suggested additions or deletions, or general comments below (please include page number references).

CUT ALONG LINE

03376 REV. 4/79 PRINTED IN U.S.A.

NO POSTAGE STAMP NECESSARY IF MAILED IN U.S.A.

FOLD ON DOTTED LINES AND STAPLE

STAPLE

STAPLE

FOLD

FOLD



NO POSTAGE  
NECESSARY  
IF MAILED  
IN THE  
UNITED STATES

**BUSINESS REPLY MAIL**  
FIRST CLASS      PERMIT NO. 8241      MINNEAPOLIS, MINN.

POSTAGE WILL BE PAID BY  
**CONTROL DATA CORPORATION**  
Technical Publications Department  
2401 North Fairview Avenue  
St. Paul, Minnesota 55113



CUT ALONG LINE

FOLD

FOLD

03377



CORPORATE HEADQUARTERS, P.O. BOX 0, MINNEAPOLIS, MINN. 55440  
SALES OFFICES AND SERVICE CENTERS IN MAJOR CITIES THROUGHOUT THE WORLD

LITHO IN U.S.A.



CONTROL DATA CORPORATION